

TP-LINK®

User Guide

TL-SL5428

24-Port 10/100 + 4-Port Gigabit Managed Switch



COPYRIGHT & TRADEMARKS

Specifications are subject to change without notice. **TP-LINK®** is a registered trademark of TP-LINK TECHNOLOGIES CO., LTD. Other brands and product names are trademarks or registered trademarks of their respective holders.

No part of the specifications may be reproduced in any form or by any means or used to make any derivative such as translation, transformation, or adaptation without permission from TP-LINK TECHNOLOGIES CO., LTD. Copyright © 2008 TP-LINK TECHNOLOGIES CO., LTD. All rights reserved.

<http://www.tp-link.com>

FCC STATEMENT



This equipment has been tested and found to comply with the limits for a Class A digital device, pursuant to part 15 of the FCC Rules. These limits are designed to provide reasonable protection against harmful interference in a residential installation. This equipment generates, uses and can radiate radio frequency energy and, if not installed and used in accordance with the instructions, may cause harmful interference to radio communications. However, there is no guarantee that interference will not occur in a particular installation. If this equipment does cause harmful interference to radio or television reception, which can be determined by turning the equipment off and on, the user is encouraged to try to correct the interference by one or more of the following measures:

- Reorient or relocate the receiving antenna.
- Increase the separation between the equipment and receiver.
- Connect the equipment into an outlet on a circuit different from that to which the receiver is connected.
- Consult the dealer or an experienced radio/ TV technician for help.

This device complies with part 15 of the FCC Rules. Operation is subject to the following two conditions:

- 1) This device may not cause harmful interference.
- 2) This device must accept any interference received, including interference that may cause undesired operation.

Any changes or modifications not expressly approved by the party responsible for compliance could void the user's authority to operate the equipment.

CE Mark Warning



This is a class A product. In a domestic environment, this product may cause radio interference, in which case the user may be required to take adequate measures.

Contents

Chapter 1: Introduction	1-1
Key Features	1-1
Description of Software Features	1-2
System Defaults	1-6

Chapter 2: Initial Configuration	2-1
Connecting to the Switch	2-1
Configuration Options	2-1
Required Connections	2-2
Remote Connections	2-3
Basic Configuration	2-3
Console Connection	2-3
Setting Passwords	2-4
Setting an IP Address	2-4
Manual Configuration	2-4
Dynamic Configuration	2-5
Enabling SNMP Management Access	2-6
Community Strings (for SNMP version 1 and 2c clients)	2-6
Trap Receivers	2-7
Configuring Access for SNMP Version 3 Clients	2-8
Saving Configuration Settings	2-8
Managing System Files	2-9

Chapter 3: Configuring the Switch	3-1
Using the Web Interface	3-1
Navigating the Web Browser Interface	3-2
Home Page	3-2
Configuration Options	3-3
Panel Display	3-3
Main Menu	3-4
Basic Configuration	3-12
Displaying System Information	3-12
Displaying Switch Hardware/Software Versions	3-13
Displaying Bridge Extension Capabilities	3-15
Setting the Switch's IP Address	3-16
Manual Configuration	3-17
Using DHCP/BOOTP	3-18
Enabling Jumbo Frames	3-19
Managing Firmware	3-19
Downloading System Software from a Server	3-20

Saving or Restoring Configuration Settings	3-21
Downloading Configuration Settings from a Server	3-22
Console Port Settings	3-23
Telnet Settings	3-25
Configuring Event Logging	3-28
Displaying Log Messages	3-28
System Log Configuration	3-28
Remote Log Configuration	3-30
Simple Mail Transfer Protocol	3-31
Resetting the System	3-33
Setting the System Clock	3-34
Setting the Time Manually	3-34
Configuring SNTP	3-34
Configuring NTP	3-35
Setting the Time Zone	3-37
Simple Network Management Protocol	3-38
Setting Community Access Strings	3-40
Specifying Trap Managers and Trap Types	3-41
Enabling SNMP Agent Status	3-42
Configuring SNMPv3 Management Access	3-43
Setting the Local Engine ID	3-43
Specifying a Remote Engine ID	3-45
Configuring SNMPv3 Users	3-45
Configuring Remote SNMPv3 Users	3-47
Configuring SNMPv3 Groups	3-48
Setting SNMPv3 Views	3-50
User Authentication	3-51
Configuring User Accounts	3-52
Configuring Local/Remote Logon Authentication	3-54
Configuring Encryption Keys	3-58
AAA Authorization and Accounting	3-59
Configuring AAA RADIUS Group Settings	3-60
Configuring AAA TACACS+ Group Settings	3-60
Configuring AAA Accounting	3-61
AAA Accounting Update	3-63
AAA Accounting 802.1X Port Settings	3-63
AAA Accounting Exec Command Privileges	3-64
AAA Accounting Exec Settings	3-66
AAA Accounting Summary	3-66
Authorization Settings	3-68
Authorization EXEC Settings	3-69
Authorization Summary	3-69
Configuring HTTPS	3-70
Replacing the Default Secure-site Certificate	3-71
Configuring the Secure Shell	3-72

Configuring the SSH Server	3-75
Generating the Host Key Pair	3-76
Importing User Public Keys	3-77
Configuring Port Security	3-81
Configuring 802.1X Port Authentication	3-82
Displaying 802.1X Global Settings	3-84
Configuring 802.1X Global Settings	3-84
Configuring Port Settings for 802.1X	3-85
Displaying 802.1X Statistics	3-88
Web Authentication	3-89
Configuring Web Authentication	3-90
Configuring Web Authentication for Ports	3-91
Displaying Web Authentication Port Information	3-92
Re-authenticating Web Authenticated Ports	3-93
Network Access – MAC Address Authentication	3-94
Configuring the MAC Authentication Reauthentication Time	3-95
Configuring MAC Authentication for Ports	3-95
Configuring Port Link Detection	3-97
Displaying Secure MAC Address Information	3-98
MAC Authentication	3-99
Configuring MAC authentication parameters for ports	3-99
Access Control Lists	3-100
Configuring Access Control Lists	3-101
Setting the ACL Name and Type	3-101
Configuring a Standard IP ACL	3-102
Configuring an Extended IP ACL	3-103
Configuring a MAC ACL	3-106
Binding a Port to an Access Control List	3-107
Filtering IP Addresses for Management Access	3-108
Port Configuration	3-111
Displaying Connection Status	3-111
Configuring Interface Connections	3-113
Creating Trunk Groups	3-115
Statically Configuring a Trunk	3-116
Enabling LACP on Selected Ports	3-117
Configuring LACP Parameters	3-119
Displaying LACP Port Counters	3-121
Displaying LACP Settings and Status for the Local Side	3-123
Displaying LACP Settings and Status for the Remote Side	3-125
Setting Broadcast Storm Thresholds	3-126
Configuring Port Mirroring	3-128
Configuring Rate Limits	3-129
Rate Limit Configuration	3-129
Showing Port Statistics	3-130
Address Table Settings	3-134

Setting Static Addresses	3-134
Displaying the Address Table	3-135
Changing the Aging Time	3-137
Spanning Tree Algorithm Configuration	3-137
Configuring Port and Trunk Loopback Detection	3-139
Displaying Global Settings	3-141
Configuring Global Settings	3-143
Displaying Interface Settings	3-147
Configuring Interface Settings	3-149
Configuring Multiple Spanning Trees	3-151
Displaying Interface Settings for MSTP	3-154
Configuring Interface Settings for MSTP	3-156
VLAN Configuration	3-158
IEEE 802.1Q VLANs	3-158
Enabling or Disabling GVRP (Global Setting)	3-161
Displaying Basic VLAN Information	3-162
Displaying Current VLANs	3-162
Creating VLANs	3-164
Adding Static Members to VLANs (VLAN Index)	3-165
Adding Static Members to VLANs (Port Index)	3-167
Configuring VLAN Behavior for Interfaces	3-168
Configuring IEEE 802.1Q Tunneling	3-170
Enabling QinQ Tunneling on the Switch	3-173
Adding an Interface to a QinQ Tunnel	3-175
Private VLANs	3-176
Displaying Current Private VLANs	3-177
Configuring Private VLANs	3-178
Associating VLANs	3-179
Displaying Private VLAN Interface Information	3-180
Configuring Private VLAN Interfaces	3-181
Protocol VLANs	3-182
Protocol VLAN Group Configuration	3-182
Protocol VLAN System Configuration	3-183
Link Layer Discovery Protocol	3-184
Setting LLDP Timing Attributes	3-184
Configuring LLDP Interface Attributes	3-186
Displaying LLDP Local Device Information	3-189
Displaying LLDP Remote Port Information	3-190
Displaying LLDP Remote Information Details	3-191
Displaying Device Statistics	3-192
Displaying Detailed Device Statistics	3-193
Class of Service Configuration	3-194
Layer 2 Queue Settings	3-194
Setting the Default Priority for Interfaces	3-194
Mapping CoS Values to Egress Queues	3-195

Enabling CoS	3-197
Selecting the Queue Mode	3-198
Setting the Service Weight for Traffic Classes	3-198
Layer 3/4 Priority Settings	3-199
Mapping Layer 3/4 Priorities to CoS Values	3-199
Enabling IP DSCP Priority	3-200
Mapping DSCP Priority	3-201
Quality of Service	3-202
Configuring Quality of Service Parameters	3-203
Configuring a Class Map	3-203
Creating QoS Policies	3-206
Attaching a Policy Map to Ingress Queues	3-209
VoIP Traffic Configuration	3-210
Configuring VoIP Traffic	3-210
Configuring VoIP Traffic Port	3-211
Configuring Telephony OUI	3-213
Multicast Filtering	3-215
Layer 2 IGMP (Snooping and Query)	3-215
Configuring IGMP Snooping and Query Parameters	3-216
Enabling IGMP Immediate Leave	3-218
Displaying Interfaces Attached to a Multicast Router	3-219
Specifying Static Interfaces for a Multicast Router	3-220
Displaying Port Members of Multicast Services	3-221
Assigning Ports to Multicast Services	3-222
IGMP Filtering and Throttling	3-223
Enabling IGMP Filtering and Throttling	3-224
Configuring IGMP Filter Profiles	3-225
Configuring IGMP Filtering and Throttling for Interfaces	3-226
Multicast VLAN Registration	3-228
Configuring Global MVR Settings	3-229
Displaying MVR Interface Status	3-230
Displaying Port Members of Multicast Groups	3-231
Configuring MVR Interface Status	3-232
Assigning Static Multicast Groups to Interfaces	3-234
DHCP Snooping	3-235
DHCP Snooping Configuration	3-236
DHCP Snooping VLAN Configuration	3-236
DHCP Snooping Information Option Configuration	3-237
DHCP Snooping Port Configuration	3-238
DHCP Snooping Binding Information	3-239
IP Source Guard	3-240
IP Source Guard Port Configuration	3-240
Static IP Source Guard Binding Configuration	3-241
Dynamic IP Source Guard Binding Information	3-242
Switch Clustering	3-243

Cluster Configuration	3-244
Cluster Member Configuration	3-245
Cluster Member Information	3-246
Cluster Candidate Information	3-247
UPnP	3-248
UPnP Configuration	3-248
<hr/>	
Chapter 4: Command Line Interface	4-1
Using the Command Line Interface	4-1
Accessing the CLI	4-1
Console Connection	4-1
Telnet Connection	4-2
Entering Commands	4-3
Keywords and Arguments	4-3
Minimum Abbreviation	4-3
Command Completion	4-3
Getting Help on Commands	4-3
Showing Commands	4-4
Partial Keyword Lookup	4-6
Negating the Effect of Commands	4-6
Using Command History	4-6
Understanding Command Modes	4-6
Exec Commands	4-7
Configuration Commands	4-8
Command Line Processing	4-10
Command Groups	4-11
Line Commands	4-12
line	4-13
login	4-13
password	4-14
timeout login response	4-15
exec-timeout	4-15
password-thresh	4-16
silent-time	4-17
databits	4-17
parity	4-18
speed	4-19
stopbits	4-19
disconnect	4-20
show line	4-20
General Commands	4-21
enable	4-21
disable	4-22
configure	4-23

show history	4-23
reload	4-24
reload cancel	4-24
show reload	4-25
end	4-25
exit	4-26
quit	4-26
System Management Commands	4-27
Device Designation Commands	4-27
prompt	4-27
hostname	4-28
Banner	4-28
banner configure	4-29
banner configure company	4-30
banner configure dc-power-info	4-31
banner configure department	4-31
banner configure equipment-info	4-32
banner configure equipment-location	4-33
banner configure ip-lan	4-33
banner configure ip-number	4-34
banner configure manager-info	4-35
banner configure mux	4-35
banner configure note	4-36
show banner	4-37
User Access Commands	4-38
username	4-38
enable password	4-39
IP Filter Commands	4-40
management	4-40
show management	4-41
Web Server Commands	4-42
ip http port	4-42
ip http server	4-42
ip http secure-server	4-43
ip http secure-port	4-44
Telnet Server Commands	4-45
ip telnet port	4-45
ip telnet server	4-45
Secure Shell Commands	4-46
ip ssh server	4-48
ip ssh timeout	4-49
ip ssh authentication-retries	4-49
ip ssh server-key size	4-50
delete public-key	4-50
ip ssh crypto host-key generate	4-51

ip ssh crypto zeroize	4-51
ip ssh save host-key	4-52
show ip ssh	4-52
show ssh	4-53
show public-key	4-54
Event Logging Commands	4-55
logging on	4-55
logging history	4-56
logging host	4-57
logging facility	4-57
logging trap	4-58
clear logging	4-58
show logging	4-59
show log	4-60
SMTP Alert Commands	4-61
logging sendmail host	4-61
logging sendmail level	4-62
logging sendmail source-email	4-63
logging sendmail destination-email	4-63
logging sendmail	4-64
show logging sendmail	4-64
Time Commands	4-65
sntp client	4-65
sntp server	4-66
sntp poll	4-67
show sntp	4-67
ntp client	4-68
ntp server	4-69
ntp poll	4-70
ntp authenticate	4-70
ntp authentication-key	4-71
show ntp	4-72
clock timezone-predefined	4-72
clock timezone	4-73
clock summer-time (date)	4-74
clock summer-time (predefined)	4-75
clock summer-time (recurring)	4-76
calendar set	4-77
show calendar	4-77
System Status Commands	4-78
show startup-config	4-78
show running-config	4-79
show system	4-82
show users	4-82
show version	4-83

Frame Size Commands	4-84
jumbo frame	4-84
Flash/File Commands	4-85
copy	4-85
delete	4-88
dir	4-89
whichboot	4-90
boot system	4-90
Authentication Commands	4-91
Authentication Sequence	4-91
authentication login	4-92
authentication enable	4-93
RADIUS Client	4-94
radius-server host	4-95
radius-server acct-port	4-95
radius-server auth-port	4-96
radius-server key	4-96
radius-server retransmit	4-97
radius-server timeout	4-97
show radius-server	4-97
TACACS+ Client	4-98
tacacs-server host	4-98
tacacs-server port	4-99
tacacs-server key	4-99
tacacs-server retransmit	4-100
tacacs-server timeout	4-100
show tacacs-server	4-101
AAA Commands	4-102
aaa group server	4-102
server	4-103
aaa accounting dot1x	4-103
aaa accounting exec	4-104
aaa accounting commands	4-105
aaa accounting update	4-106
accounting dot1x	4-107
accounting exec	4-107
accounting commands	4-108
aaa authorization exec	4-108
authorization exec	4-109
show accounting	4-110
Port Security Commands	4-111
port security	4-111
802.1X Port Authentication	4-112
dot1x system-auth-control	4-113
dot1x default	4-113

dot1x max-req	4-114
dot1x port-control	4-114
dot1x operation-mode	4-115
dot1x re-authenticate	4-115
dot1x re-authentication	4-116
dot1x timeout quiet-period	4-116
dot1x timeout re-authperiod	4-117
dot1x timeout tx-period	4-117
dot1x intrusion-action	4-118
show dot1x	4-118
Network Access – MAC Address Authentication	4-121
network-access mode	4-121
network-access max-mac-count	4-122
mac-authentication intrusion-action	4-123
mac-authentication max-mac-count	4-123
network-access dynamic-qos	4-124
network-access dynamic-vlan	4-124
network-access guest-vlan	4-125
network-access link-detection	4-125
network-access link-detection link-down	4-126
network-access link-detection link-up	4-126
network-access link-detection link-up-down	4-127
mac-authentication reauth-time	4-127
clear network-access	4-128
show network-access	4-128
show network-access mac-address-table	4-129
Web Authentication	4-130
web-auth login-attempts	4-131
web-auth login-fail-page-url	4-131
web-auth login-page-url	4-132
web-auth login-success-page-url	4-132
web-auth quiet-period	4-133
web-auth session-timeout	4-133
web-auth system-auth-control	4-134
web-auth	4-134
show web-auth	4-135
show web-auth interface	4-135
web-auth re-authenticate (Port)	4-136
web-auth re-authenticate (IP)	4-136
show web-auth summary	4-137
Access Control List Commands	4-139
IP ACLs	4-140
access-list ip	4-140
permit, deny (Standard ACL)	4-141
permit, deny (Extended ACL)	4-141

show ip access-list	4-143
ip access-group	4-143
show ip access-group	4-144
MAC ACLs	4-144
access-list mac	4-145
permit, deny (MAC ACL)	4-146
show mac access-list	4-147
mac access-group	4-148
show mac access-group	4-148
ACL Information	4-149
show access-list	4-149
show access-group	4-149
SNMP Commands	4-150
snmp-server	4-151
show snmp	4-151
snmp-server community	4-152
snmp-server contact	4-153
snmp-server location	4-153
snmp-server host	4-154
snmp-server enable traps	4-156
snmp-server engine-id	4-157
show snmp engine-id	4-158
snmp-server view	4-159
show snmp view	4-160
snmp-server group	4-160
show snmp group	4-161
snmp-server user	4-163
show snmp user	4-165
Interface Commands	4-166
interface	4-166
description	4-167
speed-duplex	4-167
negotiation	4-168
capabilities	4-169
flowcontrol	4-170
shutdown	4-171
switchport packet-rate	4-172
clear counters	4-172
show interfaces status	4-173
show interfaces counters	4-174
show interfaces switchport	4-175
Mirror Port Commands	4-177
port monitor	4-177
show port monitor	4-178
Rate Limit Commands	4-179

rate-limit	4-179
Link Aggregation Commands	4-180
channel-group	4-181
lACP	4-182
lACP system-priority	4-183
lACP admin-key (Ethernet Interface)	4-184
lACP admin-key (Port Channel)	4-185
lACP port-priority	4-186
show lACP	4-186
Address Table Commands	4-190
mac-address-table static	4-190
clear mac-address-table dynamic	4-191
show mac-address-table	4-191
mac-address-table aging-time	4-192
show mac-address-table aging-time	4-193
LLDP Commands	4-193
lldp	4-195
lldp holdtime-multiplier	4-195
lldp medFastStartCount	4-196
lldp notification-interval	4-196
lldp refresh-interval	4-197
lldp reinit-delay	4-198
lldp tx-delay	4-198
lldp admin-status	4-199
lldp notification	4-199
lldp mednotification	4-200
lldp basic-tlv management-ip-address	4-201
lldp basic-tlv port-description	4-201
lldp basic-tlv system-capabilities	4-202
lldp basic-tlv system-description	4-202
lldp basic-tlv system-name	4-203
lldp dot1-tlv proto-ident	4-203
lldp dot1-tlv proto-vid	4-204
lldp dot1-tlv pvid	4-204
lldp dot1-tlv vlan-name	4-205
lldp dot3-tlv link-agg	4-205
lldp dot3-tlv mac-phy	4-206
lldp dot3-tlv max-frame	4-206
lldp dot3-tlv poe	4-207
lldp medtlv extpoe	4-207
lldp medtlv inventory	4-208
lldp medtlv location	4-208
lldp medtlv med-cap	4-209
lldp medtlv network-policy	4-209
show lldp config	4-210

show lldp info local-device	4-212
show lldp info remote-device	4-213
show lldp info statistics	4-213
UPnP Commands	4-215
upnp device	4-215
upnp device ttl	4-216
upnp device advertise duration	4-216
show upnp	4-217
Spanning Tree Commands	4-217
spanning-tree	4-218
spanning-tree mode	4-219
spanning-tree forward-time	4-220
spanning-tree hello-time	4-221
spanning-tree max-age	4-221
spanning-tree priority	4-222
spanning-tree pathcost method	4-222
spanning-tree transmission-limit	4-223
spanning-tree mst-configuration	4-223
mst vlan	4-224
mst priority	4-225
name	4-225
revision	4-226
max-hops	4-226
spanning-tree spanning-disabled	4-227
spanning-tree cost	4-227
spanning-tree port-priority	4-228
spanning-tree edge-port	4-229
spanning-tree portfast	4-230
spanning-tree link-type	4-231
spanning-tree loopback-detection	4-231
spanning-tree loopback-detection release-mode	4-232
spanning-tree loopback-detection trap	4-233
spanning-tree mst cost	4-233
spanning-tree mst port-priority	4-234
spanning-tree protocol-migration	4-235
show spanning-tree	4-235
show spanning-tree mst configuration	4-237
VLAN Commands	4-238
GVRP and Bridge Extension Commands	4-238
bridge-ext gvrp	4-239
show bridge-ext	4-239
switchport gvrp	4-240
show gvrp configuration	4-240
garp timer	4-241
show garp timer	4-241

Editing VLAN Groups	4-242
vlan database	4-242
vlan	4-243
Configuring VLAN Interfaces	4-244
interface vlan	4-244
switchport mode	4-245
switchport acceptable-frame-types	4-246
switchport ingress-filtering	4-246
switchport native vlan	4-247
switchport allowed vlan	4-248
switchport forbidden vlan	4-249
Displaying VLAN Information	4-250
show vlan	4-250
Configuring IEEE 802.1Q Tunneling	4-251
dot1q-tunnel system-tunnel-control	4-251
switchport dot1q-tunnel mode	4-252
switchport dot1q-tunnel tpid	4-253
show dot1q-tunnel	4-253
Configuring Private VLANs	4-254
private-vlan	4-256
private vlan association	4-256
switchport mode private-vlan	4-257
switchport private-vlan host-association	4-258
switchport private-vlan isolated	4-258
switchport private-vlan mapping	4-259
show vlan private-vlan	4-259
Configuring Protocol-based VLANs	4-261
protocol-vlan protocol-group (Configuring Groups)	4-261
protocol-vlan protocol-group (Configuring VLANs)	4-262
show protocol-vlan protocol-group	4-263
show protocol-vlan protocol-group-vid	4-263
Priority Commands	4-264
Priority Commands (Layer 2)	4-264
queue mode	4-265
switchport priority default	4-265
queue bandwidth	4-266
queue cos-map	4-267
show queue mode	4-268
show queue bandwidth	4-268
show queue cos-map	4-269
Priority Commands (Layer 3 and 4)	4-269
map ip dscp (Global Configuration)	4-269
map ip dscp (Interface Configuration)	4-270
show map ip dscp	4-271
Quality of Service Commands	4-272

class-map	4-273
match	4-274
policy-map	4-275
class	4-276
set	4-277
police	4-277
service-policy	4-278
show class-map	4-279
show policy-map	4-279
show policy-map interface	4-280
Voice VLAN Commands	4-280
voice vlan	4-281
voice vlan aging	4-282
voice vlan mac-address	4-282
switchport voice vlan	4-283
switchport voice vlan rule	4-284
switchport voice vlan security	4-284
switchport voice vlan priority	4-285
show voice vlan	4-286
Multicast Filtering Commands	4-287
IGMP Snooping Commands	4-287
ip igmp snooping	4-288
ip igmp snooping vlan static	4-288
ip igmp snooping version	4-289
ip igmp snooping leave-proxy	4-289
ip igmp snooping immediate-leave	4-290
show ip igmp snooping	4-291
show mac-address-table multicast	4-291
IGMP Query Commands (Layer 2)	4-292
ip igmp snooping querier	4-292
ip igmp snooping query-count	4-293
ip igmp snooping query-interval	4-293
ip igmp snooping query-max-response-time	4-294
ip igmp snooping router-port-expire-time	4-295
Static Multicast Routing Commands	4-295
ip igmp snooping vlan mrouter	4-296
show ip igmp snooping mrouter	4-296
IGMP Filtering and Throttling Commands	4-297
ip igmp filter (Global Configuration)	4-298
ip igmp profile	4-298
permit, deny	4-299
range	4-299
ip igmp filter (Interface Configuration)	4-300
ip igmp max-groups	4-300
ip igmp max-groups action	4-301

show ip igmp filter	4-302
show ip igmp profile	4-302
show ip igmp throttle interface	4-303
Multicast VLAN Registration Commands	4-304
mvr (Global Configuration)	4-304
mvr (Interface Configuration)	4-305
show mvr	4-307
IP Interface Commands	4-309
ip address	4-309
ip default-gateway	4-310
ip dhcp restart	4-311
show ip interface	4-311
show ip redirects	4-312
ping	4-312
IP Source Guard Commands	4-313
ip source-guard	4-313
ip source-guard binding	4-315
show ip source-guard	4-316
show ip source-guard binding	4-316
DHCP Snooping Commands	4-317
ip dhcp snooping	4-317
ip dhcp snooping vlan	4-319
ip dhcp snooping trust	4-320
ip dhcp snooping verify mac-address	4-321
ip dhcp snooping information option	4-321
ip dhcp snooping information policy	4-322
ip dhcp snooping database flash	4-323
show ip dhcp snooping	4-323
show ip dhcp snooping binding	4-324
Switch Cluster Commands	4-324
cluster	4-324
cluster commander	4-325
cluster ip-pool	4-326
cluster member	4-326
rcommand	4-327
show cluster	4-327
show cluster members	4-328
show cluster candidates	4-328

Appendix A: Software Specifications	A-1
Software Features	A-1
Management Features	A-2
Standards	A-2
Management Information Bases	A-3

Appendix B: Troubleshooting	B-1
Problems Accessing the Management Interface	B-1
Using System Logs	B-2
Glossary	
Index	

Tables

Table 1-1	Key Features	1-1
Table 1-2	System Defaults	1-6
Table 3-1	Configuration Options	3-3
Table 3-2	Main Menu	3-4
Table 3-3	Logging Levels	3-29
Table 3-5	Supported Notification Messages	3-48
Table 3-6	HTTPS System Support	3-70
Table 3-7	802.1X Statistics	3-88
Table 3-8	LACP Port Counters	3-121
Table 3-9	LACP Internal Configuration Information	3-123
Table 3-10	LACP Neighbor Configuration Information	3-125
Table 3-11	Port Statistics	3-130
Table 3-12	Mapping CoS Values to Egress Queues	3-196
Table 3-13	CoS Priority Levels	3-196
Table 3-14	Mapping DSCP Priority Values	3-201
Table 4-1	Command Modes	4-7
Table 4-2	Configuration Modes	4-8
Table 4-3	Command Line Processing	4-10
Table 4-4	Command Groups	4-11
Table 4-5	Line Commands	4-12
Table 4-6	General Commands	4-21
Table 4-7	System Management Commands	4-27
Table 4-8	Device Designation Commands	4-27
Table 4-9	Banner Commands	4-28
Table 4-10	User Access Commands	4-38
Table 4-11	Default Login Settings	4-38
Table 4-12	IP Filter Commands	4-40
Table 4-13	Web Server Commands	4-42
Table 4-14	HTTPS System Support	4-43
Table 4-15	Telnet Server Commands	4-45
Table 4-16	SSH Commands	4-46
Table 4-17	show ssh - display description	4-53
Table 4-18	Event Logging Commands	4-55
Table 4-19	Logging Levels	4-56
Table 4-20	show logging flash/ram - display description	4-59
Table 4-21	show logging trap - display description	4-60
Table 4-22	SMTP Alert Commands	4-61
Table 4-23	Time Commands	4-65
Table 4-24	Predefined Summer-Time Parameters	4-75
Table 4-25	System Status Commands	4-78
Table 4-26	Frame Size Commands	4-84
Table 4-27	Flash/File Commands	4-85

Table 4-28	File Directory Information	4-89
Table 4-29	Authentication Commands	4-91
Table 4-30	Authentication Sequence	4-91
Table 4-31	RADIUS Client Commands	4-94
Table 4-32	TACACS Commands	4-98
Table 4-34	Port Security Commands	4-111
Table 4-35	802.1X Port Authentication	4-112
Table 4-36	Network Access	4-121
Table 4-37	Web Authentication	4-130
Table 4-38	Access Control Lists	4-139
Table 4-39	IP ACLs	4-140
Table 4-40	MAC ACL Commands	4-144
Table 4-41	ACL Information	4-149
Table 4-42	SNMP Commands	4-150
Table 4-43	show snmp engine-id - display description	4-158
Table 4-44	show snmp view - display description	4-160
Table 4-45	show snmp group - display description	4-163
Table 4-46	show snmp user - display description	4-165
Table 4-47	Interface Commands	4-166
Table 4-48	Interfaces Switchport Statistics	4-176
Table 4-49	Mirror Port Commands	4-177
Table 4-50	Rate Limit Commands	4-179
Table 4-51	Link Aggregation Commands	4-180
Table 4-52	show lacp counters - display description	4-187
Table 4-53	show lacp internal - display description	4-188
Table 4-54	show lacp neighbors - display description	4-189
Table 4-55	show lacp sysid - display description	4-189
Table 4-56	Address Table Commands	4-190
Table 4-57	LLDP Commands	4-193
Table 4-58	Spanning Tree Commands	4-217
Table 4-59	VLANs	4-238
Table 4-60	GVRP and Bridge Extension Commands	4-238
Table 4-61	Editing VLAN Groups	4-242
Table 4-62	Configuring VLAN Interfaces	4-244
Table 4-63	Show VLAN Commands	4-250
Table 4-64	IEEE 802.1Q Tunneling Commands	4-251
Table 4-65	Private VLAN Commands	4-254
Table 4-66	Protocol-based VLAN Commands	4-261
Table 4-67	Priority Commands	4-264
Table 4-68	Priority Commands (Layer 2)	4-264
Table 4-69	Default CoS Values to Egress Queues	4-267
Table 4-70	Priority Commands (Layer 3 and 4)	4-269
Table 4-71	IP DSCP to CoS Vales	4-270
Table 4-72	Quality of Service Commands	4-272
Table 4-73	Voice VLAN Commands	4-280

Table 4-74	Multicast Filtering Commands	4-287
Table 4-75	IGMP Snooping Commands	4-287
Table 4-76	IGMP Query Commands (Layer 2)	4-292
Table 4-77	Static Multicast Routing Commands	4-295
Table 4-78	IGMP Filtering and Throttling Commands	4-297
Table 4-79	Multicast VLAN Registration Commands	4-304
Table 4-80	show mvr - display description	4-307
Table 4-81	show mvr interface - display description	4-308
Table 4-82	show mvr members - display description	4-308
Table 4-83	IP Interface Commands	4-309
Table 4-84	IP Source Guard Commands	4-313
Table 4-85	DHCP Snooping Commands	4-317
Table 4-86	Switch Cluster Commands	4-324
Table B-1	Troubleshooting Chart	B-1

Figures

Figure 3-1	Home Page	3-2
Figure 3-2	Panel Display	3-3
Figure 3-3	System Information	3-12
Figure 3-4	Switch Information	3-14
Figure 3-5	Bridge Extension Configuration	3-15
Figure 3-6	Manual IP Configuration	3-17
Figure 3-7	DHCP IP Configuration	3-18
Figure 3-8	Jumbo Frames Configuration	3-19
Figure 3-9	Copy Firmware	3-20
Figure 3-10	Setting the Startup Code	3-20
Figure 3-11	Deleting Files	3-21
Figure 3-12	Downloading Configuration Settings for Startup	3-22
Figure 3-13	Setting the Startup Configuration Settings	3-23
Figure 3-14	Console Port Settings	3-24
Figure 3-15	Enabling Telnet	3-26
Figure 3-16	Displaying Logs	3-28
Figure 3-17	System Logs	3-29
Figure 3-18	Remote Logs	3-31
Figure 3-19	Enabling and Configuring SMTP	3-32
Figure 3-20	Resetting the System	3-33
Figure 3-21	SNTP Configuration	3-35
Figure 3-22	NTP Client Configuration	3-36
Figure 3-23	Setting the System Clock	3-38
Figure 3-24	Configuring SNMP Community Strings	3-41
Figure 3-25	Configuring IP Trap Managers	3-42
Figure 3-26	Enabling SNMP Agent Status	3-43
Figure 3-27	Setting an Engine ID	3-44
Figure 3-28	Setting a Remote Engine ID	3-45
Figure 3-29	Configuring SNMPv3 Users	3-46
Figure 3-30	Configuring Remote SNMPv3 Users	3-47
Figure 3-31	Configuring SNMPv3 Groups	3-50
Figure 3-32	Configuring SNMPv3 Views	3-51
Figure 3-33	Access Levels	3-53
Figure 3-34	Authentication Settings	3-56
Figure 3-35	Encryption Key Settings	3-58
Figure 3-36	AAA Radius Group Settings	3-60
Figure 3-37	AAA TACACS+ Group Settings	3-61
Figure 3-38	AAA Accounting Settings	3-62
Figure 3-39	AAA Accounting Update	3-63
Figure 3-40	AAA Accounting 802.1X Port Settings	3-64
Figure 3-41	AAA Accounting Exec Command Privileges	3-65
Figure 3-42	AAA Accounting Exec Settings	3-66

Figure 3-43	AAA Accounting Summary	3-67
Figure 3-44	AAA Authorization Settings	3-68
Figure 3-45	AAA Authorization Exec Settings	3-69
Figure 3-46	AAA Authorization Summary	3-70
Figure 3-47	HTTPS Settings	3-71
Figure 3-48	HTTPS Settings	3-72
Figure 3-49	SSH Server Settings	3-75
Figure 3-50	SSH Host-Key Settings	3-77
Figure 3-51	SSH User Public-Key Settings	3-79
Figure 3-52	Configuring Port Security	3-82
Figure 3-53	802.1X Global Information	3-84
Figure 3-54	802.1X Global Configuration	3-85
Figure 3-55	802.1X Port Configuration	3-86
Figure 3-56	Displaying 802.1X Port Statistics	3-89
Figure 3-57	Web Authentication Configuration	3-90
Figure 3-58	Web Authentication Port Configuration	3-91
Figure 3-59	Web Authentication Port Information	3-93
Figure 3-60	Web Authentication Port Re-authentication	3-93
Figure 3-61	Network Access Configuration	3-95
Figure 3-62	Network Access Port Configuration	3-96
Figure 3-63	Network Access Port Link Detection Configuration	3-98
Figure 3-64	Network Access MAC Address Information	3-99
Figure 3-65	MAC Authentication Port Configuration	3-100
Figure 3-66	Selecting ACL Type	3-102
Figure 3-67	Configuring Standard IP ACLs	3-103
Figure 3-68	Configuring Extended IP ACLs	3-105
Figure 3-69	Configuring MAC ACLs	3-107
Figure 3-70	Configuring ACL Port Binding	3-108
Figure 3-71	Creating an IP Filter List	3-110
Figure 3-72	Displaying Port/Trunk Information	3-111
Figure 3-73	Port/Trunk Configuration	3-114
Figure 3-74	Configuring Static Trunks	3-116
Figure 3-75	LACP Trunk Configuration	3-118
Figure 3-76	LACP Port Configuration	3-120
Figure 3-77	LACP - Port Counters Information	3-122
Figure 3-78	LACP - Port Internal Information	3-124
Figure 3-79	LACP - Port Neighbors Information	3-125
Figure 3-80	Port Broadcast Control	3-127
Figure 3-81	Mirror Port Configuration	3-128
Figure 3-82	Input Rate Limit Port Configuration	3-129
Figure 3-83	Port Statistics	3-133
Figure 3-84	Configuring a Static Address Table	3-135
Figure 3-85	Configuring a Dynamic Address Table	3-136
Figure 3-86	Setting the Address Aging Time	3-137
Figure 3-87	Configuring Port Loopback Detection	3-140

Figure 3-88	Displaying Spanning Tree Information	3-142
Figure 3-89	Configuring Spanning Tree	3-146
Figure 3-90	Displaying Spanning Tree Port Information	3-149
Figure 3-91	Configuring Spanning Tree per Port	3-151
Figure 3-92	Configuring Multiple Spanning Trees	3-153
Figure 3-93	Displaying MSTP Interface Settings	3-155
Figure 3-94	Displaying MSTP Interface Settings	3-158
Figure 3-95	Globally Enabling GVRP	3-161
Figure 3-96	Displaying Basic VLAN Information	3-162
Figure 3-97	Displaying Current VLANs	3-163
Figure 3-98	Configuring a VLAN Static List	3-165
Figure 3-99	Configuring a VLAN Static Table	3-167
Figure 3-100	VLAN Static Membership by Port	3-167
Figure 3-101	Configuring VLANs per Port	3-169
Figure 3-102	802.1Q Tunnel Status and Ethernet Type	3-174
Figure 3-103	Tunnel Port Configuration	3-176
Figure 3-104	Private VLAN Information	3-178
Figure 3-105	Private VLAN Configuration	3-179
Figure 3-106	Private VLAN Association	3-179
Figure 3-107	Private VLAN Port Information	3-180
Figure 3-108	Private VLAN Port Configuration	3-182
Figure 3-109	Protocol VLAN Configuration	3-183
Figure 3-110	Protocol VLAN System Configuration	3-184
Figure 3-111	LLDP Configuration	3-186
Figure 3-112	LLDP Port Configuration	3-188
Figure 3-113	LLDP Local Device Information	3-189
Figure 3-114	LLDP Remote Port Information	3-190
Figure 3-115	LLDP Remote Information Details	3-191
Figure 3-116	LLDP Device Statistics	3-192
Figure 3-117	LLDP Device Statistics Details	3-193
Figure 3-118	Port Priority Configuration	3-195
Figure 3-119	Traffic Classes	3-197
Figure 3-120	Enable Traffic Classes	3-198
Figure 3-121	Queue Mode	3-198
Figure 3-122	Configuring Queue Scheduling	3-199
Figure 3-123	IP DSCP Priority Status	3-200
Figure 3-124	Mapping IP DSCP Priority Values	3-201
Figure 3-125	Configuring Class Maps	3-205
Figure 3-126	Configuring Policy Maps	3-208
Figure 3-127	Service Policy Settings	3-209
Figure 3-128	Configuring VoIP Traffic	3-211
Figure 3-129	VoIP Traffic Port Configuration	3-212
Figure 3-130	Telephony OUI List	3-214
Figure 3-131	IGMP Configuration	3-218
Figure 3-132	IGMP Immediate Leave	3-219

Figure 3-133	Displaying Multicast Router Port Information	3-220
Figure 3-134	Static Multicast Router Port Configuration	3-221
Figure 3-135	IP Multicast Registration Table	3-222
Figure 3-136	IGMP Member Port Table	3-223
Figure 3-137	Enabling IGMP Filtering and Throttling	3-224
Figure 3-138	IGMP Profile Configuration	3-226
Figure 3-139	IGMP Filter and Throttling Port Configuration	3-227
Figure 3-140	MVR Global Configuration	3-230
Figure 3-141	MVR Port Information	3-231
Figure 3-142	MVR Group IP Information	3-232
Figure 3-143	MVR Port Configuration	3-233
Figure 3-144	MVR Group Member Configuration	3-234
Figure 3-145	DHCP Snooping Configuration	3-236
Figure 3-146	DHCP Snooping VLAN Configuration	3-237
Figure 3-147	DHCP Snooping Information Option Configuration	3-238
Figure 3-148	DHCP Snooping Port Configuration	3-238
Figure 3-149	DHCP Snooping Binding Information	3-239
Figure 3-150	IP Source Guard Port Configuration	3-240
Figure 3-151	Static IP Source Guard Binding Configuration	3-242
Figure 3-152	Dynamic IP Source Guard Binding Information	3-243
Figure 3-153	Cluster Member Choice	3-244
Figure 3-154	Cluster Configuration	3-245
Figure 3-155	Cluster Member Configuration	3-246
Figure 3-156	Cluster Member Information	3-246
Figure 3-157	Cluster Candidate Information	3-247
Figure 3-158	UPnP Configuration	3-248

Chapter 1: Introduction

This switch provides a broad range of features for Layer 2 switching. It includes a management agent that allows you to configure the features listed in this manual. The default configuration can be used for most of the features provided by this switch. However, there are many options that you should configure to maximize the switch's performance for your particular network environment.

Key Features

Table 1-1 Key Features

Feature	Description
Configuration Backup and Restore	Backup to TFTP server
Authentication	Console, Telnet, web – User name / password, RADIUS, TACACS+ Web – HTTPS Telnet – SSH SNMP v1/2c - Community strings SNMP version 3 – MD5 or SHA password Port – IEEE 802.1X, MAC address filtering, Web Authentication
Access Control Lists	Supports IP and MAC ACLs, 100 rules per system
DHCP Client	Supported
DHCP Snooping	Supported with Option 82 relay information
Port Configuration	Speed, duplex mode and flow control
Rate Limiting	Input rate limiting per port
Port Mirroring	One port mirrored to a single analysis port
Port Trunking	Supports up to 8 trunks using either static or dynamic trunking (LACP)
Broadcast Storm Control	Supported
Static Address	Up to 8K MAC addresses in the forwarding table
IEEE 802.1D Bridge	Supports dynamic data switching and addresses learning
Store-and-Forward Switching	Supported to ensure wire-speed switching while eliminating bad frames
Spanning Tree Algorithm	Supports standard STP, Rapid Spanning Tree Protocol (RSTP), and Multiple Spanning Trees (MSTP)
Virtual LANs	Up to 255 using IEEE 802.1Q, port-based, or private VLANs
Traffic Prioritization	Default port priority, traffic class map, queue scheduling, or Differentiated Services Code Point (DSCP), and TCP/UDP Port
Quality of Service	Supports Differentiated Services (DiffServ)
Multicast Filtering	Supports IGMP snooping and query, as well as Multicast VLAN Registration

Table 1-1 Key Features

Feature	Description
Switch Clustering	Supports up to 36 Member switches in a cluster

Description of Software Features

The switch provides a wide range of advanced performance enhancing features. Flow control eliminates the loss of packets due to bottlenecks caused by port saturation. Broadcast storm suppression prevents broadcast traffic storms from engulfing the network. Port-based and private VLANs, plus support for automatic GVRP VLAN registration provide traffic security and efficient use of network bandwidth. CoS priority queueing ensures the minimum delay for moving real-time multimedia data across the network. While multicast filtering provides support for real-time network applications. Some of the management features are briefly described below.

Configuration Backup and Restore – You can save the current configuration settings to a file on a TFTP server, and later download this file to restore the switch configuration settings.

Authentication – This switch authenticates management access via the console port, Telnet or web browser. User names and passwords can be configured locally or can be verified via a remote authentication server (i.e., RADIUS or TACACS+). Port-based authentication is also supported via the IEEE 802.1X protocol. This protocol uses the Extensible Authentication Protocol over LANs (EAPOL) to request user credentials from the 802.1X client, and then verifies the client's right to access the network via an authentication server.

Other authentication options include HTTPS for secure management access via the web, SSH for secure management access over a Telnet-equivalent connection, IP address filtering for SNMP/web/Telnet management access, and MAC address filtering for port access.

Access Control Lists – ACLs provide packet filtering for IP frames (based on address, protocol, or TCP/UDP port number) or any frames (based on MAC address or Ethernet type). ACLs can be used to improve performance by blocking unnecessary network traffic or to implement security controls by restricting access to specific network resources or protocols.

Port Configuration – You can manually configure the speed, duplex mode, and flow control used on specific ports, or use auto-negotiation to detect the connection settings used by the attached device. Use the full-duplex mode on ports whenever possible to double the throughput of switch connections. Flow control should also be enabled to control network traffic during periods of congestion and prevent the loss of packets when port buffer thresholds are exceeded. The switch supports flow control based on the IEEE 802.3x standard.

Rate Limiting – This feature controls the maximum rate for traffic received on an interface. Rate limiting is configured on interfaces at the edge of a network to limit traffic into the network. Packets that exceed the acceptable amount of traffic are dropped.

Port Mirroring – The switch can unobtrusively mirror traffic from any port to a monitor port. You can then attach a protocol analyzer or RMON probe to this port to perform traffic analysis and verify connection integrity.

Port Trunking – Ports can be combined into an aggregate connection. Trunks can be manually set up or dynamically configured using IEEE 802.3ad Link Aggregation Control Protocol (LACP). The additional ports dramatically increase the throughput across any connection, and provide redundancy by taking over the load if a port in the trunk should fail. The switch supports up to 8 trunks.

Broadcast Storm Control – Broadcast suppression prevents broadcast traffic from overwhelming the network. When enabled on a port, the level of broadcast traffic passing through the port is restricted. If broadcast traffic rises above a pre-defined threshold, it will be throttled until the level falls back beneath the threshold.

Static Addresses – A static address can be assigned to a specific interface on this switch. Static addresses are bound to the assigned interface and will not be moved. When a static address is seen on another interface, the address will be ignored and will not be written to the address table. Static addresses can be used to provide network security by restricting access for a known host to a specific port.

IEEE 802.1D Bridge – The switch supports IEEE 802.1D transparent bridging. The address table facilitates data switching by learning addresses, and then filtering or forwarding traffic based on this information. The address table supports up to 8K addresses.

Store-and-Forward Switching – The switch copies each frame into its memory before forwarding them to another port. This ensures that all frames are a standard Ethernet size and have been verified for accuracy with the cyclic redundancy check (CRC). This prevents bad frames from entering the network and wasting bandwidth.

To avoid dropping frames on congested ports, the switch provides 4 Mbits for frame buffering. This buffer can queue packets awaiting transmission on congested networks.

Spanning Tree Algorithm – The switch supports these spanning tree protocols:

Spanning Tree Protocol (STP, IEEE 802.1D) – This protocol provides loop detection and recovery by allowing two or more redundant connections to be created between a pair of LAN segments. When there are multiple physical paths between segments, this protocol will choose a single path and disable all others to ensure that only one route exists between any two stations on the network. This prevents the creation of network loops. However, if the chosen path should fail for any reason, an alternate path will be activated to maintain the connection.

Rapid Spanning Tree Protocol (RSTP, IEEE 802.1w) – This protocol reduces the convergence time for network topology changes to 3 to 5 seconds, compared to 30

seconds or more for the older IEEE 802.1D STP standard. It is intended as a complete replacement for STP, but can still interoperate with switches running the older standard by automatically reconfiguring ports to STP-compliant mode if they detect STP protocol messages from attached devices.

Multiple Spanning Tree Protocol (MSTP, IEEE 802.1s) – This protocol is a direct extension of RSTP. It can provide an independent spanning tree for different VLANs. It simplifies network management, provides for even faster convergence than RSTP by limiting the size of each region, and prevents VLAN members from being segmented from the rest of the group (as sometimes occurs with IEEE 802.1D STP).

Virtual LANs – The switch supports up to 255 VLANs. A Virtual LAN is a collection of network nodes that share the same collision domain regardless of their physical location or connection point in the network. The switch supports tagged VLANs based on the IEEE 802.1Q standard. Members of VLAN groups can be dynamically learned via GVRP, or ports can be manually assigned to a specific set of VLANs. This allows the switch to restrict traffic to the VLAN groups to which a user has been assigned. By segmenting your network into VLANs, you can:

- Eliminate broadcast storms which severely degrade performance in a flat network.
- Simplify network management for node changes/moves by remotely configuring VLAN membership for any port, rather than having to manually change the network connection.
- Provide data security by restricting all traffic to the originating VLAN.
- Use private VLANs to restrict traffic to pass only between data ports and the uplink ports, thereby isolating adjacent ports within the same VLAN, and allowing you to limit the total number of VLANs that need to be configured.
- Use protocol VLANs to restrict traffic to specified interfaces based on protocol type.

Note: The switch allows 255 user-manageable VLANs. One other VLAN (VLAN ID 4093) is reserved for switch clustering.

Traffic Prioritization – This switch prioritizes each packet based on the required level of service, using four priority queues with strict or Weighted Round Robin Queuing. It uses IEEE 802.1p and 802.1Q tags to prioritize incoming traffic based on input from the end-station application. These functions can be used to provide independent priorities for delay-sensitive data and best-effort data.

This switch also supports several common methods of prioritizing layer 3/4 traffic to meet application requirements. Traffic can be prioritized based on the DSCP field in the IP frame. When these services are enabled, the priorities are mapped to a Class of Service value by the switch, and the traffic then sent to the corresponding output queue.

Quality of Service – Differentiated Services (DiffServ) provides policy-based management mechanisms used for prioritizing network resources to meet the requirements of specific traffic types on a per-hop basis. Each packet is classified upon entry into the network based on access lists, IP Precedence or DSCP values, or VLAN lists. Using access lists allows you select traffic based on Layer 2, Layer 3, or Layer 4 information contained in each packet. Based on network policies, different kinds of traffic can be marked for different kinds of forwarding.

Multicast Filtering – Specific multicast traffic can be assigned to its own VLAN to ensure that it does not interfere with normal network traffic and to guarantee real-time delivery by setting the required priority level for the designated VLAN. The switch uses IGMP Snooping and Query to manage multicast group registration. It also supports Multicast VLAN Registration (MVR) which allows common multicast traffic, such as television channels, to be transmitted across a single network-wide multicast VLAN shared by hosts residing in other standard or private VLAN groups, while preserving security and data isolation for normal traffic.

System Defaults

The switch's system defaults are provided in the configuration file "Factory_Default_Config.cfg." To reset the switch defaults, this file should be set as the startup configuration file (page 3-21).

The following table lists some of the basic system defaults.

Table 1-2 System Defaults

Function	Parameter	Default
Console Port Connection	Baud Rate	9600
	Data bits	8
	Stop bits	1
	Parity	none
	Local Console Timeout	0 (disabled)
Authentication	Privileged Exec Level	Username "admin" Password "admin"
	Normal Exec Level	Username "guest" Password "guest"
	Enable Privileged Exec from Normal Exec Level	Password "super"
	RADIUS Authentication	Disabled
	TACACS Authentication	Disabled
	802.1X Port Authentication	Disabled
	Web Authentication	Disabled
	MAC Authentication	Disabled
	HTTPS	Enabled
	SSH	Disabled
	Port Security	Disabled
	IP Filtering	Disabled
Web Management	HTTP Server	Enabled
	HTTP Port Number	80
	HTTP Secure Server	Enabled
	HTTP Secure Port Number	443
SNMP	Community Strings	"public" (read only) "private" (read/write)
	Traps	Authentication traps: enabled Link-up-down events: enabled

Table 1-2 System Defaults (Continued)

Function	Parameter	Default
Port Configuration	Admin Status	Enabled
	Auto-negotiation	Enabled
	Flow Control	Disabled
Rate Limiting	Input limits	Disabled
Port Trunking	Static Trunks	None
	LACP (all ports)	Disabled
Broadcast Storm Protection	Status	Enabled (all ports)
	Broadcast Limit Rate	64 kbits per second
Spanning Tree Algorithm	Status	Enabled, RSTP (Defaults: All values based on IEEE 802.1w)
	Fast Forwarding (Edge Port)	Disabled
Address Table	Aging Time	300 seconds
Virtual LANs	Default VLAN	1
	PVID	1
	Acceptable Frame Type	All
	Ingress Filtering	Enabled
	Switchport Mode (Egress Mode)	Hybrid: tagged/untagged frames
	GVRP (global)	Disabled
	GVRP (port interface)	Disabled
Traffic Prioritization	Ingress Port Priority	0
	Weighted Round Robin	Queue: 0 1 2 3 Weight: 1 2 4 8
	IP DSCP Priority	Disabled
IP Settings	IP Address	DHCP assigned, otherwise 192.168.1.1
	Subnet Mask	255.255.255.0
	Default Gateway	0.0.0.0
	DHCP	Client: Enabled
	BOOTP	Disabled
Multicast Filtering	IGMP Snooping	Snooping: Enabled Querier: Enabled
	Multicast VLAN Registration	Disabled

Table 1-2 System Defaults (Continued)

Function	Parameter	Default
System Log	Status	Enabled
	Messages Logged	Levels 0-6 (all)
	Messages Logged to Flash	Levels 0-3
SMTP Email Alerts	Event Handler	Enabled (but no server defined)
SNTP	Clock Synchronization	Disabled
NTP	Clock Synchronization	Disabled
DHCP Snooping	Status	Disabled
IP Source Guard	Status	Disabled (all ports)
Switch Clustering	Status	Enabled
	Commander	Disabled

Chapter 2: Initial Configuration

Connecting to the Switch

Configuration Options

The switch includes a built-in network management agent. The agent offers a variety of management options, including SNMP, RMON (Groups 1, 2, 3, 9) and a web-based interface. A PC may also be connected directly to the switch for configuration and monitoring via a command line interface (CLI).

Note: The IP address for this switch is obtained via DHCP by default. To change this address, see “Setting an IP Address” on page 2-4.

The switch’s HTTP web agent allows you to configure switch parameters, monitor port connections, and display statistics using a standard web browser such as Netscape version 6.2 and higher or Microsoft IE version 5.0 and higher. The switch’s web management interface can be accessed from any computer attached to the network.

The CLI program can be accessed by a direct connection to the RS-232 serial console port on the switch, or remotely by a Telnet connection over the network.

The switch’s management agent also supports SNMP (Simple Network Management Protocol). This SNMP agent permits the switch to be managed from any system in the network using network management software such as HP OpenView.

The switch’s web interface, CLI configuration program, and SNMP agent allow you to perform the following management functions:

- Set user names and passwords
- Set an IP interface for a management VLAN
- Configure SNMP parameters
- Enable/disable any port
- Set the speed/duplex mode for any port
- Configure the bandwidth of any port by limiting input rates
- Control port access through IEEE 802.1X security or static address filtering
- Filter packets using Access Control Lists (ACLs)
- Configure up to 255 IEEE 802.1Q VLANs
- Enable GVRP automatic VLAN registration
- Configure IGMP multicast filtering
- Upload and download system firmware via TFTP
- Upload and download switch configuration files via TFTP
- Configure Spanning Tree parameters
- Configure Class of Service (CoS) priority queuing

- Configure up to 8 static or LACP trunks
- Enable port mirroring
- Set broadcast storm control on any port
- Display system information and statistics

Required Connections

The switch provides an RS-232 serial port that enables a connection to a PC or terminal for monitoring and configuring the switch. A null-modem console cable is provided with the switch.

Attach a VT100-compatible terminal, or a PC running a terminal emulation program to the switch. You can use the console cable provided with this package, or use a null-modem cable that complies with the wiring assignments shown in the Installation Guide.

To connect a terminal to the console port, complete the following steps:

1. Connect the console cable to the serial port on a terminal, or a PC running terminal emulation software, and tighten the captive retaining screws on the DB-9 connector.
2. Connect the other end of the cable to the RS-232 serial port on the switch.
3. Make sure the terminal emulation software is set as follows:
 - Select the appropriate serial port (COM port 1 or COM port 2).
 - Set the baud rate to 9600 bps.
 - Set the data format to 8 data bits, 1 stop bit, and no parity.
 - Set flow control to none.
 - Set the emulation mode to VT100.
 - When using HyperTerminal, select Terminal keys, not Windows keys.

- Notes:**
1. Refer to “Line Commands” on page 4-11 for a complete description of console configuration options.
 2. Once you have set up the terminal correctly, the console login screen will be displayed.

For a description of how to use the CLI, see “Using the Command Line Interface” on page 4-1. For a list of all the CLI commands and detailed information on using the CLI, refer to “Command Groups” on page 4-10.

Remote Connections

Prior to accessing the switch's onboard agent via a network connection, you must first configure it with a valid IP address, subnet mask, and default gateway using a console connection, DHCP or BOOTP protocol.

The IP address for this switch is obtained via DHCP by default. To manually configure this address or enable dynamic address assignment via DHCP or BOOTP, see "Setting an IP Address" on page 2-4.

Note: This switch supports four concurrent Telnet/SSH sessions.

After configuring the switch's IP parameters, you can access the onboard configuration program from anywhere within the attached network. The onboard configuration program can be accessed using Telnet from any computer attached to the network. The switch can also be managed by any computer using a web browser (Internet Explorer 5.0 or above, or Netscape 6.2 or above), or from a network computer using SNMP network management software.

Note: The onboard program only provides access to basic configuration functions. To access the full range of SNMP management functions, you must use SNMP-based network management software.

Basic Configuration

Console Connection

The CLI program provides two different command levels — normal access level (Normal Exec) and privileged access level (Privileged Exec). The commands available at the Normal Exec level are a limited subset of those available at the Privileged Exec level and allow you to only display information and use basic utilities. To fully configure the switch parameters, you must access the CLI at the Privileged Exec level.

Access to both CLI levels are controlled by user names and passwords. The switch has a default user name and password for each level. To log into the CLI at the Privileged Exec level using the default user name and password, perform these steps:

1. To initiate your console connection, press <Enter>. The "User Access Verification" procedure starts.
2. At the Username prompt, enter "admin."
3. At the Password prompt, also enter "admin." (The password characters are not displayed on the console screen.)
4. The session is opened and the CLI displays the "Console#" prompt indicating you have access at the Privileged Exec level.

Setting Passwords

Note: If this is your first time to log into the CLI program, you should define new passwords for both default user names using the “username” command, record them and put them in a safe place.

Passwords can consist of up to 8 alphanumeric characters and are case sensitive. To prevent unauthorized access to the switch, set the passwords as follows:

1. Open the console interface with the default user name and password “admin” to access the Privileged Exec level.
2. Type “configure” and press <Enter>.
3. Type “username guest password 0 *password*,” for the Normal Exec level, where *password* is your new password. Press <Enter>.
4. Type “username admin password 0 *password*,” for the Privileged Exec level, where *password* is your new password. Press <Enter>.

Note: ‘0’ specifies the password in plain text, ‘7’ specifies the password in encrypted form.

```
Username: admin
Password:

CLI session with the TL-SL5428 is opened.
To end the CLI session, enter [Exit].

Console#configure
Console(config)#username guest password 0 [password]
Console(config)#username admin password 0 [password]
Console(config)#
```

Setting an IP Address

You must establish IP address information for the stack to obtain management access through the network. This can be done in either of the following ways:

Manual — You have to input the information, including IP address and subnet mask. If your management station is not in the same IP subnet as the stack’s master unit, you will also need to specify the default gateway router.

Dynamic — The switch sends IP configuration requests to BOOTP or DHCP address allocation servers on the network.

Manual Configuration

You can manually assign an IP address to the switch. You may also need to specify a default gateway that resides between this device and management stations that exist on another network segment. Valid IP addresses consist of four decimal numbers, 0 to 255, separated by periods. Anything outside this format will not be accepted by the CLI program.

Note: The IP address for this switch is obtained via DHCP by default.

Before you can assign an IP address to the switch, you must obtain the following information from your network administrator:

- IP address for the switch
- Default gateway for the network
- Network mask for this network

To assign an IP address to the switch, complete the following steps:

1. From the Privileged Exec level global configuration mode prompt, type “interface vlan 1” to access the interface-configuration mode. Press <Enter>.
2. Type “ip address *ip-address netmask*,” where “ip-address” is the switch IP address and “netmask” is the network mask for the network. Press <Enter>.
3. Type “exit” to return to the global configuration mode prompt. Press <Enter>.
4. To set the IP address of the default gateway for the network to which the switch belongs, type “ip default-gateway *gateway*,” where “gateway” is the IP address of the default gateway. Press <Enter>.

```
Console(config)#interface vlan 1
Console(config-if)#ip address 192.168.1.1 255.255.255.0
Console(config-if)#exit
Console(config)#ip default-gateway 192.168.1.254
Console(config)#
```

Dynamic Configuration

If you select the “bootp” or “dhcp” option, IP will be enabled but will not function until a BOOTP or DHCP reply has been received. You therefore need to use the “ip dhcp restart” command to start broadcasting service requests. Requests will be sent periodically in an effort to obtain IP configuration information. (BOOTP and DHCP values can include the IP address, subnet mask, and default gateway.)

If the “bootp” or “dhcp” option is saved to the startup-config file (step 6), then the switch will start broadcasting service requests as soon as it is powered on.

To automatically configure the switch by communicating with BOOTP or DHCP address allocation servers on the network, complete the following steps:

1. From the Global Configuration mode prompt, type “interface vlan 1” to access the interface-configuration mode. Press <Enter>.
2. At the interface-configuration mode prompt, use one of the following commands:
 - To obtain IP settings via DHCP, type “ip address dhcp” and press <Enter>.
 - To obtain IP settings via BOOTP, type “ip address bootp” and press <Enter>.
3. Type “end” to return to the Privileged Exec mode. Press <Enter>.
4. Type “ip dhcp restart” to begin broadcasting service requests. Press <Enter>.

2 Initial Configuration

5. Wait a few minutes, and then check the IP configuration settings by typing the “show ip interface” command. Press <Enter>.
6. Then save your configuration changes by typing “copy running-config startup-config.” Enter the startup file name and press <Enter>.

```
Console(config)#interface vlan 1
Console(config-if)#ip address dhcp
Console(config-if)#end
Console#ip dhcp restart
Console#show ip interface
  IP address and netmask: 192.168.1.54 255.255.255.0 on VLAN 1,
    and address mode: User specified.
Console#copy running-config startup-config
Startup configuration file name []: startup
\Write to FLASH Programming.

\Write to FLASH finish.
Success.
```

Enabling SNMP Management Access

The switch can be configured to accept management commands from Simple Network Management Protocol (SNMP) applications such as HP OpenView. You can configure the switch to (1) respond to SNMP requests or (2) generate SNMP traps.

When SNMP management stations send requests to the switch (either to return information or to set a parameter), the switch provides the requested data or sets the specified parameter. The switch can also be configured to send information to SNMP managers (without being requested by the managers) through trap messages, which inform the manager that certain events have occurred.

The switch includes an SNMP agent that supports SNMP version 1, 2c, and 3 clients. To provide management access for version 1 or 2c clients, you must specify a community string. The switch provides a default MIB View (i.e., an SNMPv3 construct) for the default “public” community string that provides read access to the entire MIB tree, and a default view for the “private” community string that provides read/write access to the entire MIB tree. However, you may assign new views to version 1 or 2c community strings that suit your specific security requirements (see page 3-49).

Community Strings (for SNMP version 1 and 2c clients)

Community strings are used to control management access to SNMP version 1 and 2c stations, as well as to authorize SNMP stations to receive trap messages from the switch. You therefore need to assign community strings to specified users, and set the access level.

The default strings are:

- **public** - with read-only access. Authorized management stations are only able to retrieve MIB objects.
- **private** - with read-write access. Authorized management stations are able to both retrieve and modify MIB objects.

To prevent unauthorized access to the switch from SNMP version 1 or 2c clients, it is recommended that you change the default community strings.

To configure a community string, complete the following steps:

1. From the Privileged Exec level global configuration mode prompt, type “snmp-server community *string mode*,” where “string” is the community access string and “mode” is **rw** (read/write) or **ro** (read only). Press <Enter>. (Note that the default mode is read only.)
2. To remove an existing string, simply type “no snmp-server community *string*,” where “string” is the community access string to remove. Press <Enter>.

```
Console(config)#snmp-server community admin rw 4-151
Console(config)#snmp-server community private
Console(config)#
```

Note: If you do not intend to support access to SNMP version 1 and 2c clients, we recommend that you delete both of the default community strings. If there are no community strings, then SNMP management access from SNMP v1 and v2c clients is disabled.

Trap Receivers

You can also specify SNMP stations that are to receive traps from the switch. To configure a trap receiver, use the “snmp-server host” command. From the Privileged Exec level global configuration mode prompt, type:

```
“snmp-server host host-address community-string
[version {1 | 2c | 3 {auth | noauth | priv}}]”
```

where “host-address” is the IP address for the trap receiver, “community-string” specifies access rights for a version 1/2c host, or is the user name of a version 3 host, “version” indicates the SNMP client version, and “auth | noauth | priv” means that authentication, no authentication, or authentication and privacy is used for v3 clients. Then press <Enter>. For a more detailed description of these parameters, see “snmp-server host” on page 4-153. The following example creates a trap host for each type of SNMP client.

```
Console(config)#snmp-server host 10.1.19.23 batman 4-153
Console(config)#snmp-server host 10.1.19.98 robin version 2c
Console(config)#snmp-server host 10.1.19.34 barbie version 3 auth
Console(config)#
```

Configuring Access for SNMP Version 3 Clients

To configure management access for SNMPv3 clients, you need to first create a view that defines the portions of MIB that the client can read or write, assign the view to a group, and then assign the user to a group. The following example creates one view called “mib-2” that includes the entire MIB-2 tree branch, and then another view that includes the IEEE 802.1d bridge MIB. It assigns these respective read and read/write views to a group call “r&d” and specifies group authentication via MD5 or SHA. In the last step, it assigns a v3 user to this group, indicating that MD5 will be used for authentication, provides the password “greenpeace” for authentication, and the password “einstien” for encryption.

```
Console(config)#snmp-server view mib-2 1.3.6.1.2.1 included           4-158
Console(config)#snmp-server view 802.1d 1.3.6.1.2.1.17 included
Console(config)#snmp-server group r&d v3 auth mib-2 802.1d         4-159
Console(config)#snmp-server user steve group r&d v3 auth md5
greenpeace priv des56 einstien                                     4-162
Console(config)#
```

For a more detailed explanation on how to configure the switch for access from SNMP v3 clients, refer to “Simple Network Management Protocol” on page 3-38, or refer to the specific CLI commands for SNMP starting on page 4-149.

Saving Configuration Settings

Configuration commands only modify the running configuration file and are not saved when the switch is rebooted. To save all your configuration changes in nonvolatile storage, you must copy the running configuration file to the start-up configuration file using the “copy” command.

To save the current configuration settings, enter the following command:

1. From the Privileged Exec mode prompt, type “copy running-config startup-config” and press <Enter>.
2. Enter the name of the start-up file. Press <Enter>.

```
Console#copy running-config startup-config
Startup configuration file name []: startup
\Write to FLASH Programming.

\Write to FLASH finish.
Success.

Console#
```

Managing System Files

The switch's flash memory supports three types of system files that can be managed by the CLI program, web interface, or SNMP. The switch's file system allows files to be uploaded and downloaded, copied, deleted, and set as a start-up file.

The three types of files are:

- **Configuration** — This file stores system configuration information and is created when configuration settings are saved. Saved configuration files can be selected as a system start-up file or can be uploaded via TFTP to a server for backup. A file named "Factory_Default_Config.cfg" contains all the system default settings and cannot be deleted from the system. See "Saving or Restoring Configuration Settings" on page 3-21 for more information.
- **Operation Code** — System software that is executed after boot-up, also known as run-time code. This code runs the switch operations and provides the CLI and web management interfaces. See "Managing Firmware" on page 3-19 for more information.
- **Diagnostic Code** — Software that is run during system boot-up, also known as POST (Power On Self-Test).

Due to the size limit of the flash memory, the switch supports only two operation code files. However, you can have as many diagnostic code files and configuration files as available flash memory space allows.

In the system flash memory, one file of each type must be set as the start-up file. During a system boot, the diagnostic and operation code files set as the start-up file are run, and then the start-up configuration file is loaded.

Note that configuration files should be downloaded using a file name that reflects the contents or usage of the file settings. If you download directly to the running-config, the system will reboot, and the settings will have to be copied from the running-config to a permanent file.

2 Initial Configuration

Chapter 3: Configuring the Switch

Using the Web Interface

This switch provides an embedded HTTP web agent. Using a web browser you can configure the switch and view statistics to monitor network activity. The web agent can be accessed by any computer on the network using a standard web browser (Internet Explorer 5.0 or above, or Netscape 6.2 or above).

Note: You can also use the Command Line Interface (CLI) to manage the switch over a serial connection to the console port or via Telnet. For more information on using the CLI, refer to Chapter 4: "Command Line Interface."

Prior to accessing the switch from a web browser, be sure you have first performed the following tasks:

1. Configure the switch with a valid IP address, subnet mask, and default gateway using an out-of-band serial connection, BOOTP or DHCP protocol. (See "Setting an IP Address" on page 2-4.)
2. Set user names and passwords using an out-of-band serial connection. Access to the web agent is controlled by the same user names and passwords as the onboard configuration program. (See "Setting Passwords" on page 2-4)
3. After you enter a user name and password, you will have access to the system configuration program.

- Notes:**
1. You are allowed three attempts to enter the correct password; on the third failed attempt the current connection is terminated.
 2. If you log into the web interface as guest (Normal Exec level), you can view the configuration settings or change the guest password. If you log in as "admin" (Privileged Exec level), you can change the settings on any page.
 3. If the path between your management station and this switch does not pass through any device that uses the Spanning Tree Algorithm, then you can set the switch port attached to your management station to fast forwarding (i.e., enable Admin Edge Port) to improve the switch's response time to management commands issued through the web interface. See "Configuring Interface Settings" on page 3-148.

Navigating the Web Browser Interface

To access the web-browser interface you must first enter a user name and password. The administrator has Read/Write access to all configuration parameters and statistics. The default user name and password for the administrator is “admin.”

Home Page

When your web browser connects with the switch’s web agent, the home page is displayed as shown below. The home page displays the Main Menu on the left side of the screen and System Information on the right side. The Main Menu links are used to navigate to other menus, and display configuration parameters and statistics.

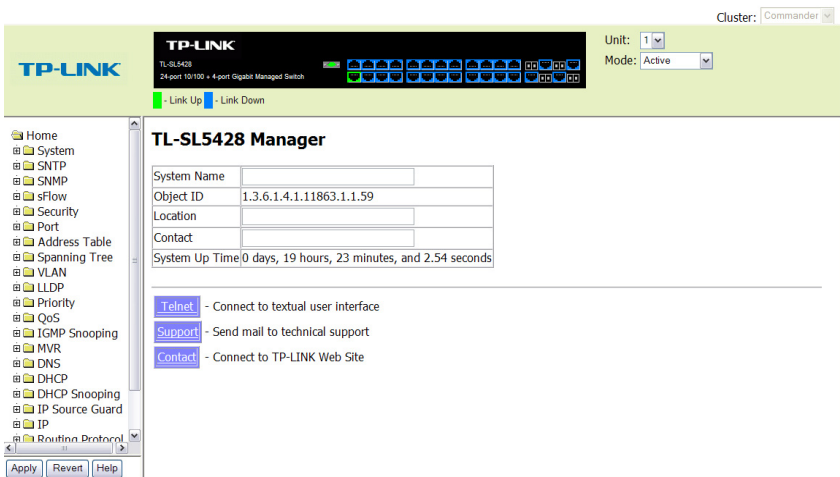

Figure 3-1 Home Page

Configuration Options

Configurable parameters have a dialog box or a drop-down list. Once a configuration change has been made on a page, be sure to click on the Apply button to confirm the new setting. The following table summarizes the web page configuration buttons.

Table 3-1 Configuration Options

Button	Action
Revert	Cancels specified values and restores current values prior to pressing Apply.
Apply	Sets specified values to the system.
Help	Links directly to webhelp.

- Notes:**
- To ensure proper screen refresh, be sure that Internet Explorer is configured so that the setting "Check for newer versions of stored pages" reads "Every visit to the page".
 Internet Explorer 6.x and earlier: This option is available under the menu "Tools / Internet Options / General / Temporary Internet Files / Settings".
 Internet Explorer 7.x: This option is available under "Tools / Internet Options / General / Browsing History / Settings / Temporary Internet Files".
 - You may have to manually refresh the screen after making configuration changes by pressing the browser's refresh button.

Panel Display

The web agent displays an image of the switch's ports. The Mode can be set to display different information for the ports, including Active (i.e., up or down), Duplex (i.e., half or full duplex, or Flow Control (i.e., with or without flow control). Clicking on the image of a port opens the Port Configuration page as described on page 3-112.



Figure 3-2 Panel Display

Main Menu

Using the onboard web agent, you can define system parameters, manage and control the switch, and all its ports, or monitor network conditions. The following table briefly describes the selections available from this program.

Table 3-2 Main Menu

Menu	Description	Page
System		3-12
System Information	Provides basic system description, including contact information	3-12
Switch Information	Shows the number of ports, hardware/firmware version numbers, and power status	3-13
Bridge Extension Configuration	Shows the bridge extension parameters	3-15
IP Configuration	Sets the IP address for management access	3-16
Jumbo Frames	Enables jumbo frame packets.	3-19
File Management		3-19
Copy Operation	Allows the transfer and copying of files	3-19
Delete	Allows deletion of files from the flash memory	3-20
Set Start-Up	Sets the startup file	3-20
Line		3-23
Console	Sets console port connection parameters	3-23
Telnet	Sets Telnet connection parameters	3-25
Log		3-28
Logs	Stores and displays error messages	3-28
System Logs	Sends error messages to a logging process	3-28
Remote Logs	Configures the logging of messages to a remote logging process	3-30
SMTP	Sends an SMTP client message to a participating server.	3-31
Reset	Restarts the switch	3-33
SNTP		3-34
Configuration	Configures SNTP and NTP client settings, including broadcast mode, authentication parameters or a specified list of servers	3-34
Clock Time Zone	Sets the local time zone for the system clock	3-37
SNMP		3-38
Configuration	Configures community strings and related trap functions	3-40
Agent Status	Enables or disables SNMP Agent Status	3-42
SNMPv3		3-42
Engine ID	Sets the SNMP v3 engine ID on this switch	3-42

Table 3-2 Main Menu (Continued)

Menu	Description	Page
Remote Engine ID	Sets the SNMP v3 engine ID for a remote device	3-44
Users	Configures SNMP v3 users on this switch	3-44
Remote Users	Configures SNMP v3 users from a remote device	3-46
Groups	Configures SNMP v3 groups	3-47
Views	Configures SNMP v3 views	3-49
Security		3-50
User Accounts	Assigns a new password for the current user	3-51
Authentication Settings	Configures authentication sequence, RADIUS and TACACS	3-53
Encryption Key	Configures RADIUS and TACACS encryption key settings	3-57
AAA		3-58
RADIUS Group Settings	Defines the configured RADIUS servers to use for accounting	3-59
TACACS+ Group Settings	Defines the configured TACACS+ servers to use for accounting	3-59
Accounting		
Settings	Configures accounting of requested services for billing or security purposes	3-60
Periodic Update	Sets the interval at which accounting updates are sent to RADIUS AAA servers	3-62
802.1X Port Settings	Applies the specified accounting method to an interface	3-62
Exec Settings	Specifies console or Telnet authentication method	3-65
Summary	Displays accounting information and statistics	3-65
Authorization		3-67
Settings	Configures authorization of requested services	3-67
EXEC Settings	Specifies console or Telnet authorization method	3-68
Summary	Displays authorization information	3-68
AAA		3-58
HTTPS Settings	Configures secure HTTP settings	3-57
SSH		3-71
Settings	Configures Secure Shell server settings	3-80
Host-Key Settings	Generates the host key pair (public and private)	3-75
SSH User Public-Key Settings	Imports and manages user RSA and DSA public keys	3-77
Port Security	Configures per port security, including status, response for security breach, and maximum allowed MAC addresses	3-80
802.1X		3-81

3 Configuring the Switch

Table 3-2 Main Menu (Continued)

Menu	Description	Page
Information	Displays global configuration settings for 802.1X Port authentication	3-83
Configuration	Configures the global configuration settings	3-83
Port Configuration	Sets parameters for individual ports	3-84
Statistics	Displays protocol statistics for the selected port	3-87
Web Authentication		3-88
Configuration	Configures Web Authentication settings	3-89
Port Configuration	Enables Web Authentication for individual ports	3-90
Port Information	Displays status information for individual ports	3-91
Re-authentication	Forces a host to re-authenticate itself immediately	3-92
Network Access		3-93
Configuration	Configures global Network Access parameters	3-94
Port Configuration	Configures Network Access parameters for individual ports	3-94
Port Link Detection Configuration	Configures Port Link Detection parameters	3-96
MAC Address Information	Displays Network Access statistics sorted by various attributes	3-97
MAC Authentication		3-98
Port Configuration	Configures MAC Authentication parameters for ports	3-98
ACL		3-100
Configuration	Configures packet filtering based on IP or MAC addresses	3-100
Port Binding	Binds a port to the specified ACL	3-106
IP Filter	Sets IP addresses of clients allowed management access via the web, SNMP, and Telnet	3-107
Port		3-110
Port Information	Displays port connection status	3-110
Trunk Information	Displays trunk connection status	3-110
Port Configuration	Configures port connection settings	3-112
Trunk Configuration	Configures trunk connection settings	3-112
Trunk Membership	Specifies ports to group into static trunks	3-115
LACP		3-116
Configuration	Allows ports to dynamically join trunks	3-116
Aggregation Port	Configures parameters for link aggregation group members	3-118
Port Counters Information	Displays statistics for LACP protocol messages	3-120
Port Internal Information	Displays settings and operational state for the local side	3-122

Table 3-2 Main Menu (Continued)

Menu	Description	Page
Port Neighbors Information	Displays settings and operational state for the remote side	3-124
Port Broadcast Control	Sets the broadcast storm threshold for each port	3-125
Trunk Broadcast Control	Sets the broadcast storm threshold for each trunk	3-125
Mirror Port Configuration	Sets the source and target ports for mirroring	3-127
Rate Limit		3-128
Input Port Configuration	Sets the input rate limit for each port	3-128
Input Trunk Configuration	Sets the input rate limit for each trunk	3-128
Output Port Configuration	Sets the output rate limit for ports	3-128
Output Trunk Configuration	Sets the output rate limit for trunks	3-128
Port Statistics	Lists Ethernet and RMON port statistics	3-129
Address Table		3-133
Static Addresses	Displays entries for interface, address or VLAN	3-133
Dynamic Addresses	Displays or edits static entries in the Address Table	3-134
Address Aging	Sets timeout for dynamically learned entries	3-136
Spanning Tree		3-137
Port Loopback Detection	Configures Port Loopback Detection parameters	3-139
Trunk Loopback Detection	Configures Trunk Loopback Detection parameters	3-139
STA		3-137
Information	Displays STA values used for the bridge	3-140
Configuration	Configures global bridge settings for STA and RSTP	3-142
Port Information	Displays individual port settings for STA	3-146
Trunk Information	Displays individual trunk settings for STA	3-146
Port Configuration	Configures individual port settings for STA	3-148
Trunk Configuration	Configures individual trunk settings for STA	3-148
MSTP		3-150
VLAN Configuration	Configures priority and VLANs for a spanning tree instance	3-150
Port Information	Displays port settings for a specified MST instance	3-153
Trunk Information	Displays trunk settings for a specified MST instance	3-153
Port Configuration	Configures port settings for a specified MST instance	3-155
Trunk Configuration	Configures trunk settings for a specified MST instance	3-155
VLAN		3-157
802.1Q VLAN		3-157

Table 3-2 Main Menu (Continued)

Menu	Description	Page
GVRP Status	Enables GVRP on the switch	3-160
802.1Q Tunnel Configuration	Enables 802.1Q (QinQ) Tunneling	3-172
Basic Information	Displays information on the VLAN type supported by this switch	3-161
Current Table	Shows the current port members of each VLAN and whether or not the port is tagged or untagged	3-161
Static List	Used to create or remove VLAN groups	3-163
Static Table	Modifies the settings for an existing VLAN	3-164
Static Membership by Port	Configures membership type for interfaces, including tagged, untagged or forbidden	3-166
Port Configuration	Specifies default PVID and VLAN attributes	3-167
Trunk Configuration	Specifies default trunk VID and VLAN attributes	3-167
Tunnel Port Configuration	Adds an interface to a QinQ Tunnel	3-174
Tunnel Trunk Configuration	Adds an interface to a QinQ Tunnel	3-174
Private VLAN		3-175
Information	Displays Private VLAN feature information	3-176
Configuration	This page is used to create/remove primary or community VLANs	3-177
Association	Each community VLAN must be associated with a primary VLAN	3-178
Port Information	Shows VLAN port type, and associated primary or secondary VLANs	3-179
Port Configuration	Sets the private VLAN interface type, and associates the interfaces with a private VLAN	3-180
Trunk Information	Shows VLAN port type, and associated primary or secondary VLANs	3-179
Trunk Configuration	Sets the private VLAN interface type, and associates the interfaces with a private VLAN	3-180
Protocol VLAN		3-181
Configuration	Configures protocol VLANs	3-181
System Configuration	Configures protocol VLAN system parameters	3-182
LLDP		3-183
Configuration	Configures global LLDP timing parameters	3-183
Port Configuration	Configures parameters for individual ports	3-185
Trunk Configuration	Configures parameters for trunks	3-185
Local Information	Displays LLDP information about the local device	3-188

Table 3-2 Main Menu (Continued)

Menu	Description	Page
Remote Port Information	Displays LLDP information about a remote device connected to a port on this switch	3-189
Remote Trunk Information	Displays LLDP information about a remote device connected to a trunk on this switch	3-189
Remote Information Details	Displays detailed LLDP information about a remote device connected to this switch	3-190
Device Statistics	Displays LLDP statistics for all connected remote devices	3-191
Device Statistics Details	Displays LLDP statistics for remote devices on a selected port or trunk	3-192
Priority		3-193
Default Port Priority	Sets the default priority for each port	3-193
Default Trunk Priority	Sets the default priority for each trunk	3-193
Traffic Classes	Maps IEEE 802.1p priority tags to output queues	3-194
Traffic Classes Status	Enables/disables traffic class priorities (not implemented)	3-196
Queue Mode	Sets queue mode to strict priority or Weighted Round-Robin	3-197
Queue Scheduling	Configures Weighted Round Robin queueing	3-197
IP DSCP Priority Status	Globally selects DSCP Priority, or disables it.	3-199
IP DSCP Priority	Sets IP Differentiated Services Code Point priority, mapping a DSCP tag to a class-of-service value	3-200
QoS		3-201
DiffServ		3-201
Class Map	Sets Class Maps	3-202
Policy Map	Sets Policy Maps	3-205
Service Policy	Defines service policy settings for ports	3-208
VoIP Traffic Setting		3-209
Configuration	VoIP Traffic Setting Configuration	3-209
Port Configuration	Configures VoIP Traffic Settings for ports	3-210
OUI Configuration	Defines OUI settings	3-212
IGMP Snooping		3-214
IGMP Configuration	Enables multicast filtering; configures parameters for multicast query	3-215
IGMP Filter Configuration	Configures IGMP filtering	3-194
IGMP Immediate Leave	Enables the immediate leave function	3-217
Multicast Router Port Information	Displays the ports that are attached to a neighboring multicast router for each VLAN ID	3-218

3 Configuring the Switch

Table 3-2 Main Menu (Continued)

Menu	Description	Page
Static Multicast Router Port Configuration	Assigns ports that are attached to a neighboring multicast router	3-219
IP Multicast Registration Table	Displays all multicast groups active on this switch, including multicast IP addresses and VLAN ID	3-220
IGMP Member Port Table	Indicates multicast addresses associated with the selected VLAN	3-221
IGMP Filter Profile Configuration	Configures IGMP Filter Profiles	3-195
IGMP Filter/Throttling Port Configuration	Configures IGMP Filtering and Throttling for ports	3-196
IGMP Filter/Throttling Trunk Configuration	Configures IGMP Filtering and Throttling for trunks	3-196
MVR		3-227
Configuration	Globally enables MVR, sets the MVR VLAN, adds multicast stream addresses	3-228
Port Information	Displays MVR interface type, MVR operational and activity status, and immediate leave status	3-229
Trunk Information	Displays MVR interface type, MVR operational and activity status, and immediate leave status	3-229
Group IP Information	Displays the ports attached to an MVR multicast stream	3-230
Port Configuration	Configures MVR interface type and immediate leave status	3-231
Trunk Configuration	Configures MVR interface type and immediate leave status	3-231
Group Member Configuration	Statically assigns MVR multicast streams to an interface	3-233
DHCP Snooping		3-234
Configuration	Enables DHCP Snooping and DHCP Snooping MAC-Address Verification	3-235
VLAN Configuration	Enables DHCP Snooping for a VLAN	3-235
Information Option Configuration	Enables DHCP Snooping Information Option	3-236
Port Configuration	Selects the DHCP Snooping Information Option policy	3-237
Binding Information	Displays the DHCP Snooping binding information	3-238
IP Source Guard		3-239
Port Configuration	Enables IP source guard and selects filter type per port	3-239
Static Configuration	Adds a static addresses to the source-guard binding table	3-240
Dynamic Information	Displays the source-guard binding table for a selected interface	3-241
Cluster		3-242
Configuration	Globally enables clustering for the switch	3-243

Table 3-2 Main Menu (Continued)

Menu	Description	Page
Member Configuration	Adds switch Members to the cluster	3-244
Member Information	Displays cluster Member switch information	3-245
Candidate Information	Displays network Candidate switch information	3-246
UPNP		3-247
Configuration	Enables UPNP and defines timeout values	3-247

Basic Configuration

Displaying System Information

You can easily identify the system by displaying the device name, location and contact information.

Field Attributes

- **System Name** – Name assigned to the switch system.
- **Object ID** – MIB II object ID for switch's network management subsystem.
- **Location** – Specifies the system location.
- **Contact** – Administrator responsible for the system.
- **System Up Time** – Length of time the management agent has been up.

These additional parameters are displayed for the CLI.

- **MAC Address** – The physical layer address for this switch.
- **Web server** – Shows if management access via HTTP is enabled.
- **Web server port** – Shows the TCP port number used by the web interface.
- **Web secure server** – Shows if management access via HTTPS is enabled.
- **Web secure server port** – Shows the TCP port used by the HTTPS interface.
- **Telnet server** – Shows if management access via Telnet is enabled.
- **Telnet port** – Shows the TCP port used by the Telnet interface.
- **Jumbo Frame** – Shows if jumbo frames are enabled.
- **POST result** – Shows results of the power-on self-test.

Web – Click System, System Information. Specify the system name, location, and contact information for the system administrator, then click Apply. (This page also includes a Telnet button that allows access to the Command Line Interface via Telnet.)

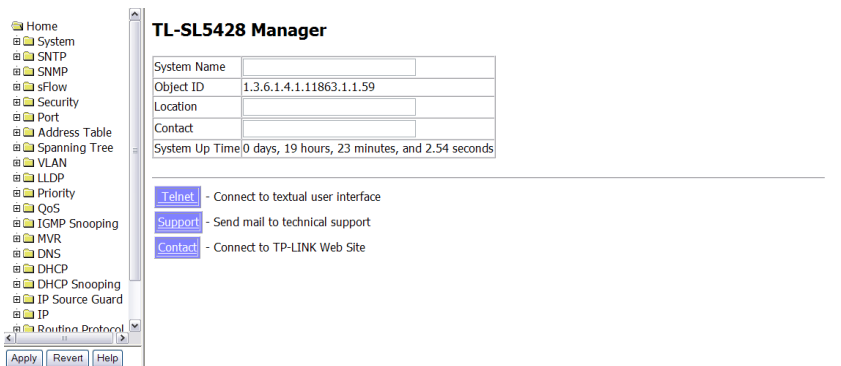

Figure 3-3 System Information

CLI – Specify the hostname, location and contact information.

```

Console(config)#hostname R&D 5                               4-27
Console(config)#snmp-server location WC 9                   4-152
Console(config)#snmp-server contact Ted                     4-152
Console(config)#exit
Console#show system                                         4-81
System description      : TL-SL5428
System OID string      : 1.3.6.1.4.1.11863.1.1.59
System information
System Up time         : 0 days, 0 hours, 14 minutes, and 32.93 seconds
System Name           : R&D 5
System Location       : WC 9
System Contact        : Ted
MAC address           : 00-00-35-28-10-03
Web server            : enabled
Web server port       : 80
Web secure server     : enabled
Web secure server port : 443
Telnet server         : enable
Telnet port           : 23
Jumbo Frame           : Disabled
POST result
UART Loopback Test ..... PASS
DRAM Test ..... PASS
Timer Test ..... PASS
PCI Device 1 Test ..... PASS
I2C Bus Initialization ..... PASS
Switch Int Loopback Test .... PASS
Fan Speed Test ..... PASS

Done All Pass.
Console#

```

Displaying Switch Hardware/Software Versions

Use the Switch Information page to display hardware/firmware version numbers for the main board and management software, as well as the power status of the system.

Field Attributes*Main Board*

- **Serial Number** – The serial number of the switch.
- **Number of Ports** – Number of built-in RJ-45 ports.
- **Hardware Version** – Hardware version of the main board.
- **Internal Power Status** – Displays the status of the internal power supply.

Management Software

- **EPLD Version** – Version number of the Electronically Programmable Logic Device code.
- **Loader Version** – Version number of loader code.
- **Boot-ROM Version** – Version of Power-On Self-Test (POST) and boot code.
- **Operation Code Version** – Version number of runtime code.
- **Role** – Shows that this switch is operating as Master or Slave.

3 Configuring the Switch

Web – Click System, Switch Information.

Switch Information

Main Board:

Serial Number	A733006612
Number of Ports	28
Hardware Version	R01
Chip Device ID	Marvell 98DX107-A2, 88E6095[F]
Internal Power Status	Active

Management Software:

EPLD Version	0.07
Loader Version	1.0.0.1
Boot-ROM Version	1.0.0.8
Operation Code Version	1.3.0.2
Role	Master

Figure 3-4 Switch Information

CLI – Use the following command to display version information.

```
Console#show version 4-82
Unit 1
  Serial number:      A733006612
  Hardware version:   R01
  Chip Device ID:     Marvell 98DX107-A2, 88E6095[F]
  EPLD Version:       0.07
  Number of ports:    28
  Main power status:  Up
  Redundant power status: Not present

Agent (master)
  Unit ID:            1
  Loader version:     1.0.0.1
  Boot ROM version:   1.0.0.8
  Operation code version: 1.3.0.2

Console#
```

Displaying Bridge Extension Capabilities

The Bridge MIB includes extensions for managed devices that support Multicast Filtering, Traffic Classes, and Virtual LANs. You can access these extensions to display default settings for the key variables.

Field Attributes

- **Extended Multicast Filtering Services** – This switch does not support the filtering of individual multicast addresses based on GMRP (GARP Multicast Registration Protocol).
- **Traffic Classes** – This switch provides mapping of user priorities to multiple traffic classes. (Refer to “Class of Service Configuration” on page 3-193.)
- **Static Entry Individual Port** – This switch allows static filtering for unicast and multicast addresses. (Refer to “Setting Static Addresses” on page 3-133.)
- **VLAN Learning** – This switch uses Shared VLAN Learning (SVL), where all VLANs share the same address table.
- **Configurable PVID Tagging** – This switch allows you to override the default Port VLAN ID (PVID used in frame tags) and egress status (VLAN-Tagged or Untagged) on each port. (Refer to “VLAN Configuration” on page 3-157.)
- **Local VLAN Capable** – This switch does not support multiple local bridges outside of the scope of 802.1Q defined VLANs.
- **GMRP** – GARP Multicast Registration Protocol (GMRP) allows network devices to register endstations with multicast groups. This switch does not support GMRP; it uses the Internet Group Management Protocol (IGMP) to provide automatic multicast filtering.

Web – Click System, Bridge Extension Configuration.

Bridge Extension Configuration

Bridge Capability

Extended Multicast Filtering Services	No
Traffic Classes	Enabled
Static Entry Individual Port	Yes
VLAN Learning	SVL
Configurable PVID Tagging	Yes
Local VLAN Capable	No

GMRP Enabled

Figure 3-5 Bridge Extension Configuration

3 Configuring the Switch

CLI – Enter the following command.

```
Console#show bridge-ext 4-239
Max support VLAN numbers:      256
Max support VLAN ID:          4092
Extended multicast filtering services: No
Static entry individual port:  Yes
VLAN learning:                 IVL
Configurable PVID tagging:     Yes
Local VLAN capable:           No
Traffic classes:               Enabled
Global GVRP status:           Disabled
GMRP:                          Disabled
Console#
```

Setting the Switch's IP Address

This section describes how to configure an IP interface for management access over the network. The IP address for the stack is obtained via DHCP by default. To manually configure an address, you need to change the switch's default settings (IP address 192.168.1.1 and netmask 255.255.255.0) to values that are compatible with your network. You may also need to establish a default gateway between the stack and management stations that exist on another network segment.

You can manually configure a specific IP address, or direct the device to obtain an address from a BOOTP or DHCP server. Valid IP addresses consist of four decimal numbers, 0 to 255, separated by periods. Anything outside this format will not be accepted by the CLI program.

Command Attributes

- **Management VLAN** – ID of the configured VLAN (1-4092, no leading zeroes). By default, all ports on the switch are members of VLAN 1. However, the management station can be attached to a port belonging to any VLAN, as long as that VLAN has been assigned an IP address.
- **IP Address Mode** – Specifies whether IP functionality is enabled via manual configuration (Static), Dynamic Host Configuration Protocol (DHCP), or Boot Protocol (BOOTP). If DHCP/BOOTP is enabled, IP will not function until a reply has been received from the server. Requests will be broadcast periodically by the switch for an IP address. (DHCP/BOOTP values can include the IP address, subnet mask, and default gateway.)
- **IP Address** – Address of the VLAN interface that is allowed management access. Valid IP addresses consist of four numbers, 0 to 255, separated by periods. (Default: 0.0.0.0)
- **Subnet Mask** – This mask identifies the host address bits used for routing to specific subnets. (Default: 255.0.0.0)
- **Gateway IP address** – IP address of the gateway router between this device and management stations that exist on other network segments. (Default: 0.0.0.0)
- **MAC Address** – The physical layer address for this switch.
- **Restart DHCP** – Requests a new IP address from the DHCP server.

Manual Configuration

Web – Click System, IP Configuration. Select the VLAN through which the management station is attached, set the IP Address Mode to “Static,” enter the IP address, subnet mask and gateway, then click Apply.

IP Configuration

Management VLAN	1
IP Address Mode	Static
IP Address	192.168.1.1
Subnet Mask	255.255.255.0
Gateway IP Address	0.0.0.0
MAC Address	00-00-35-28-10-03

Figure 3-6 Manual IP Configuration

CLI – Specify the management interface, IP address and default gateway.

```
Console#config
Console(config)#interface vlan 1                               4-166
Console(config-if)#ip address 192.168.1.1 255.255.255.0      4-309
Console(config-if)#exit
Console(config)#ip default-gateway 0.0.0.0                   4-310
Console(config)#
```

3 Configuring the Switch

Using DHCP/BOOTP

If your network provides DHCP/BOOTP services, you can configure the switch to be dynamically configured by these services.

Web – Click System, IP Configuration. Specify the VLAN to which the management station is attached, set the IP Address Mode to DHCP or BOOTP. Click Apply to save your changes. Then click Restart DHCP to immediately request a new address. Note that the switch will also broadcast a request for IP configuration settings on each power reset.

IP Configuration

Management VLAN	1
IP Address Mode	DHCP
IP Address	192.168.1.1
Subnet Mask	255.255.255.0
Gateway IP Address	0.0.0.0
MAC Address	00-00-35-28-10-03

Restart DHCP

Figure 3-7 DHCP IP Configuration

Note: If you lose your management connection, use a console connection and enter “show ip interface” to determine the new switch address.

CLI – Specify the management interface, and set the IP address mode to DHCP or BOOTP, and then enter the “ip dhcp restart” command.

```
Console#config
Console(config)#interface vlan 1                               4-166
Console(config-if)#ip address dhcp                             4-309
Console(config-if)#end
Console#ip dhcp restart                                       4-311
Console#show ip interface                                     4-311
  IP address and netmask: 192.168.1.1 255.255.255.0 on VLAN 1,
  and address mode:      User specified.
Console#
```

Renewing DCHP – DHCP may lease addresses to clients indefinitely or for a specific period of time. If the address expires or the switch is moved to another network segment, you will lose management access to the switch. In this case, you can reboot the switch or submit a client request to restart DHCP service via the CLI.

Web – If the address assigned by DHCP is no longer functioning, you will not be able to renew the IP settings via the web interface. You can only restart DHCP service via the web interface if the current address is still available.

CLI – Enter the following command to restart DHCP service.

```
Console#ip dhcp restart
Console#
```

4-311

Enabling Jumbo Frames

You can enable jumbo frames to support data packets up to 9000 bytes in size.

Command Attributes

- **Jumbo Packet Status** – Check the box to enable jumbo frames.

Web – Click System, Jumbo Frames.



Jumbo Frames

Jumbo Packet Status Enabled

Figure 3-8 Jumbo Frames Configuration

CLI – Enter the following command.

```
Console#config
Console(config)#jumbo frame
Console(config)#
```

Managing Firmware

You can upload/download firmware to or from a TFTP server, or copy files to and from switch units in a stack. By saving runtime code to a file on a TFTP server, that file can later be downloaded to the switch to restore operation. You can also set the switch to use new firmware without overwriting the previous version. You must specify the method of file transfer, along with the file type and file names as required.

Command Attributes

- **File Transfer Method** – The firmware copy operation includes these options:
 - file to file – Copies a file within the switch directory, assigning it a new name.
 - file to tftp – Copies a file from the switch to a TFTP server.
 - tftp to file – Copies a file from a TFTP server to the switch.
- **TFTP Server IP Address** – The IP address of a TFTP server.
- **File Type** – Specify opcode (operational code) to copy firmware.

3 Configuring the Switch

- **File Name** – The file name should not contain slashes (\ or /), the leading letter of the file name should not be a period (.), and the maximum length for file names on the TFTP server is 127 characters or 31 characters for files on the switch. (Valid characters: A-Z, a-z, 0-9, “.”, “-”, “_”)

Note: Up to two copies of the system software (i.e., the runtime firmware) can be stored in the file directory on the switch. The currently designated startup version of this file cannot be deleted.

Downloading System Software from a Server

When downloading runtime code, you can specify the destination file name to replace the current image, or first download the file using a different name from the current runtime code file, and then set the new file as the startup file.

Web –Click System, File Management, Copy Operation. Select “tftp to file” as the file transfer method, enter the IP address of the TFTP server, set the file type to “opcode,” enter the file name of the software to download, select a file on the switch to overwrite or specify a new file name, then click Apply. If you replaced the current firmware used for startup and want to start using the new operation code, reboot the system via the System/Reset menu.

Copy

tftp to file ▾

TFTP Server IP Address	192.168.1.19
File Type	opcode ▾
Source File Name	TL-SL5428_V1.3.0.
Destination File Name	<input type="radio"/> TL-SL5428_V1.1.0.14.bix ▾ <input checked="" type="radio"/> TL-SL5428_V1.3.0.

Figure 3-9 Copy Firmware

If you download to a new destination file, go to the System/File/Set Start-Up menu, mark the operation code file used at startup, and click Apply. To start the new firmware, reboot the system via the System/Reset menu.

Set Start-Up

Note: You can only change one file type at a time.

	Name	Type	Startup	Size(bytes)
<input type="radio"/>	Factory_Default_Config.cfg	Config_File	N	455
<input checked="" type="radio"/>	startup1.cfg	Config_File	Y	3874
<input type="radio"/>	test.txt	Config_File	N	4878
<input checked="" type="radio"/>	TL-SL5428_V1.3.0.2.bix	Operation_Code	Y	4163476
<input type="radio"/>	TL-SL5428_V1.1.0.14.bix	Operation_Code	N	3926212

Figure 3-10 Setting the Startup Code

To delete a file, select System, File, Delete. Select the file name from the given list by checking the tick box and click Apply. Note that the file currently designated as the startup code cannot be deleted.

Delete

	Name	Type	Startup	Size (bytes)
<input type="checkbox"/>	Factory_Default_Config.cfg	Config_File	N	455
<input type="checkbox"/>	startup1.cfg	Config_File	Y	3874
<input type="checkbox"/>	test.txt	Config_File	N	4878
<input type="checkbox"/>	TL-SL5428_V1.3.0.2.bix	Operation_Code	Y	4163476
<input checked="" type="checkbox"/>	TL-SL5428_V1.1.0.14.bix	Operation_Code	N	3926212

Figure 3-11 Deleting Files

CLI – To download new firmware form a TFTP server, enter the IP address of the TFTP server, select “opcode” as the file type, then enter the source and destination file names. When the file has finished downloading, set the new file to start up the system, and then restart the switch.

To start the new firmware, enter the “reload” command or reboot the system.

```

Console#copy tftp file                                     4-84
TFTP server ip address: 192.168.1.19
Choose file type:
 1. config:  2. opcode:  4. diag:  5. loader: <1,2,4,5>: 2
Source file name: TL-SL5428_V1.3.0.2.bix
Destination file name: TL-SL5428_V1.3.0.2
\Write to FLASH Programming.
-Write to FLASH finish.
Success.
Console#config
Console(config)#boot system opcode:TL-SL5428_V1.3.0.2    4-89
Console(config)#exit
Console#reload                                           4-23

```

Saving or Restoring Configuration Settings

You can upload/download configuration settings to/from a TFTP server. The configuration files can be later downloaded to restore the switch’s settings.

Command Attributes

- **File Transfer Method** – The configuration copy operation includes these options:
 - file to file – Copies a file within the switch directory, assigning it a new name.
 - file to running-config – Copies a file in the switch to the running configuration.
 - file to startup-config – Copies a file in the switch to the startup configuration.
 - file to tftp – Copies a file from the switch to a TFTP server.
 - running-config to file – Copies the running configuration to a file.
 - running-config to startup-config – Copies the running config to the startup config.
 - running-config to tftp – Copies the running configuration to a TFTP server.
 - startup-config to file – Copies the startup configuration to a file on the switch.
 - startup-config to running-config – Copies the startup config to the running config.

3 Configuring the Switch

- startup-config to tftp – Copies the startup configuration to a TFTP server.
- tftp to file – Copies a file from a TFTP server to the switch.
- tftp to running-config – Copies a file from a TFTP server to the running config.
- tftp to startup-config – Copies a file from a TFTP server to the startup config.
- **TFTP Server IP Address** – The IP address of a TFTP server.
- **File Type** – Specify config (configuration) to copy configuration settings.
- **File Name** — The file name should not contain slashes (\ or /), the leading letter of the file name should not be a period (.), and the maximum length for file names on the TFTP server is 127 characters or 31 characters for files on the switch. (Valid characters: A-Z, a-z, 0-9, “.”, “-”, “_”)

Note: The maximum number of user-defined configuration files is limited only by available flash memory space.

Downloading Configuration Settings from a Server

You can download the configuration file under a new file name and then set it as the startup file, or you can specify the current startup configuration file as the destination file to directly replace it. Note that the file “Factory_Default_Config.cfg” can be copied to the TFTP server, but cannot be used as the destination on the switch.

Web – Click System, File, Copy Operation. Select “tftp to startup-config” or “tftp to file” and enter the IP address of the TFTP server. Specify the name of the file to download and select a file on the switch to overwrite or specify a new file name, then click Apply.

The screenshot shows a web interface titled "Copy". At the top, there is a dropdown menu set to "tftp to startup-config". Below this, there are three rows of input fields:

FFTP Server IP Address	192.168.1.19
Source File Name	config-startup
Startup File Name	<input type="radio"/> Factory_Default_Config.cfg <input checked="" type="radio"/> startup

Figure 3-12 Downloading Configuration Settings for Startup

If you download to a new file name using “tftp to startup-config” or “tftp to file,” the file is automatically set as the start-up configuration file. To use the new settings, reboot the system via the System/Reset menu.

Note: You can also select any configuration file as the start-up configuration by using the System/File/Set Start-Up page.

Set Start-Up				
	Name	Type	Startup	Size(bytes)
<input type="radio"/>	Factory_Default_Config.cfg	Config_File	N	5197
<input checked="" type="radio"/>	startup	Config_File	Y	5571
<input checked="" type="radio"/>	V2271.F	Operation_Code	Y	1761944

Figure 3-13 Setting the Startup Configuration Settings

CLI – Enter the IP address of the TFTP server, specify the source file on the server, set the startup file name on the switch, and then restart the switch.

```

Console#copy tftp startup-config                               4-84
TFTP server ip address: 192.168.1.19
Source configuration file name: config-1
Startup configuration file name [] : startup
\Write to FLASH Programming.
-Write to FLASH finish.
Success.
Console#reload

```

To select another configuration file as the start-up configuration, use the **boot system** command and then restart the switch.

```

Console#config
Console(config)#boot system config: startup-new              4-89
Console(config)#exit
Console#reload                                              4-23

```

Console Port Settings

You can access the onboard configuration program by attaching a VT100 compatible device to the switch's serial console port. Management access through the console port is controlled by various parameters, including a password, timeouts, and basic communication settings. These parameters can be configured via the web or CLI interface.

Command Attributes

- **Login Timeout** – Sets the interval that the system waits for a user to log into the CLI. If a login attempt is not detected within the timeout interval, the connection is terminated for the session. (Range: 0-300 seconds; Default: 0 seconds)
- **Exec Timeout** – Sets the interval that the system waits until user input is detected. If user input is not detected within the timeout interval, the current session is terminated. (Range: 0-65535 seconds; Default: 600 seconds)
- **Password Threshold** – Sets the password intrusion threshold, which limits the number of failed logon attempts. When the logon attempt threshold is reached, the

3 Configuring the Switch

system interface becomes silent for a specified amount of time (set by the Silent Time parameter) before allowing the next logon attempt.

(Range: 0-120; Default: 3 attempts)

- **Silent Time** – Sets the amount of time the management console is inaccessible after the number of unsuccessful logon attempts has been exceeded. (Range: 0-65535; Default: 0)
- **Data Bits** – Sets the number of data bits per character that are interpreted and generated by the console port. If parity is being generated, specify 7 data bits per character. If no parity is required, specify 8 data bits per character. (Default: 8 bits)
- **Parity** – Defines the generation of a parity bit. Communication protocols provided by some terminals can require a specific parity bit setting. Specify Even, Odd, or None. (Default: None)
- **Speed** – Sets the terminal line's baud rate for transmit (to terminal) and receive (from terminal). Set the speed to match the baud rate of the device connected to the serial port. (Range: 9600, 19200, 38400 baud, or Auto; Default: Auto)
- **Stop Bits** – Sets the number of the stop bits transmitted per byte. (Range: 1-2; Default: 1 stop bit)
- **Password**¹ – Specifies a password for the line connection. When a connection is started on a line with password protection, the system prompts for the password. If you enter the correct password, the system shows a prompt. (Default: No password)
- **Login**¹ – Enables password checking at login. You can select authentication by a single global password as configured for the Password parameter, or by passwords set up for specific user-name accounts. (Default: Local)

Web – Click System, Line, Console. Specify the console port connection parameters as required, then click Apply.

Console

Login Timeout (0-300)	<input type="text" value="0"/>	secs (0 : Disabled)
Exec Timeout (0-65535)	<input type="text" value="600"/>	secs (0 : Disabled)
Password Threshold (0-120)	<input type="text" value="3"/>	(0 : Disabled)
Silent Time (0-65535)	<input type="text" value="0"/>	secs (0 : Disabled)
Data Bits	<input type="text" value="8"/>	
Parity	<input type="text" value="None"/>	
Speed	<input type="text" value="Auto"/>	
Stop Bits	<input type="text" value="1"/>	

Figure 3-14 Console Port Settings

1. CLI only.

CLI – Enter Line Configuration mode for the console, then specify the connection parameters as required. To display the current console port settings, use the **show line** command from the Normal Exec level.

```

Console(config)#line console                                4-12
Console(config-line)#login local                          4-12
Console(config-line)#password 0 secret                    4-13
Console(config-line)#timeout login response 0            4-14
Console(config-line)#exec-timeout 0                      4-14
Console(config-line)#password-thresh 3                   4-15
Console(config-line)#silent-time 60                     4-16
Console(config-line)#databits 8                         4-16
Console(config-line)#parity none                        4-17
Console(config-line)#speed 19200                       4-18
Console(config-line)#stopbits 1                        4-18
Console(config-line)#end
Console#show line                                        4-19
Console configuration:
  Password threshold: 3 times
  Interactive timeout: Disabled
  Login timeout:      Disabled
  Silent time:        60
  Baudrate:           19200
  Databits:           8
  Parity:              none
  Stopbits:           1

VTY configuration:
  Password threshold: 3 times
  Interactive timeout: 600 sec
  Login timeout:      300 sec
Console#

```

Telnet Settings

You can access the onboard configuration program over the network using Telnet (i.e., a virtual terminal). Management access via Telnet can be enabled/disabled and other various parameters set, including the TCP port number, timeouts, and a password. These parameters can be configured via the web or CLI interface.

Command Attributes

- **Telnet Status** – Enables or disables Telnet access to the switch. (Default: Enabled)
- **Telnet Port Number** – Sets the TCP port number for Telnet on the switch. (Default: 23)
- **Login Timeout** – Sets the interval that the system waits for a user to log into the CLI. If a login attempt is not detected within the timeout interval, the connection is terminated for the session. (Range: 0-300 seconds; Default: 300 seconds)
- **Exec Timeout** – Sets the interval that the system waits until user input is detected. If user input is not detected within the timeout interval, the current session is terminated. (Range: 0-65535 seconds; Default: 600 seconds)

3 Configuring the Switch

- **Password Threshold** – Sets the password intrusion threshold, which limits the number of failed logon attempts. When the logon attempt threshold is reached, the system interface becomes silent for a specified amount of time (set by the Silent Time parameter) before allowing the next logon attempt. (Range: 0-120; Default: 3 attempts)
- **Password²** – Specifies a password for the line connection. When a connection is started on a line with password protection, the system prompts for the password. If you enter the correct password, the system shows a prompt. (Default: No password)
- **Login²** – Enables password checking at login. You can select authentication by a single global password as configured for the Password parameter, or by passwords set up for specific user-name accounts. (Default: Local)

Web – Click System, Line, Telnet. Specify the connection parameters for Telnet access, then click Apply.

Telnet

Telnet Status	<input checked="" type="checkbox"/> Enabled
Telnet Port Number	23
Login Timeout (0-300)	300 secs
Exec Timeout (0-65535)	600 secs
Password Threshold (0-120)	3 (0 : Disabled)

Figure 3-15 Enabling Telnet

2. CLI only.

CLI – Enter Line Configuration mode for a virtual terminal, then specify the connection parameters as required. To display the current virtual terminal settings, use the **show line** command from the Normal Exec level.

```
Console(config)#line vty 4-12
Console(config-line)#login local 4-12
Console(config-line)#password 0 secret 4-13
Console(config-line)#timeout login response 300 4-14
Console(config-line)#exec-timeout 600 4-14
Console(config-line)#password-thresh 3 4-15
Console(config-line)#end
Console#show line 4-19
Console configuration:
  Password threshold: 3 times
  Interactive timeout: Disabled
  Login timeout: Disabled
  Silent time: Disabled
  Baudrate: 9600
  Databits: 8
  Parity: none
  Stopbits: 1

VTY configuration:
  Password threshold: 3 times
  Interactive timeout: 600 sec
  Login timeout: 300 sec
Console#
```

Configuring Event Logging

The switch allows you to control the logging of error messages, including the type of events that are recorded in switch memory, logging to a remote System Log (syslog) server, and displays a list of recent event messages.

Displaying Log Messages

The Logs page allows you to scroll through the logged system and event messages. The switch can store up to 2048 log entries in temporary random access memory (RAM; i.e., memory flushed on power reset) and up to 4096 entries in permanent flash memory.

Web – Click System, Log, Logs.

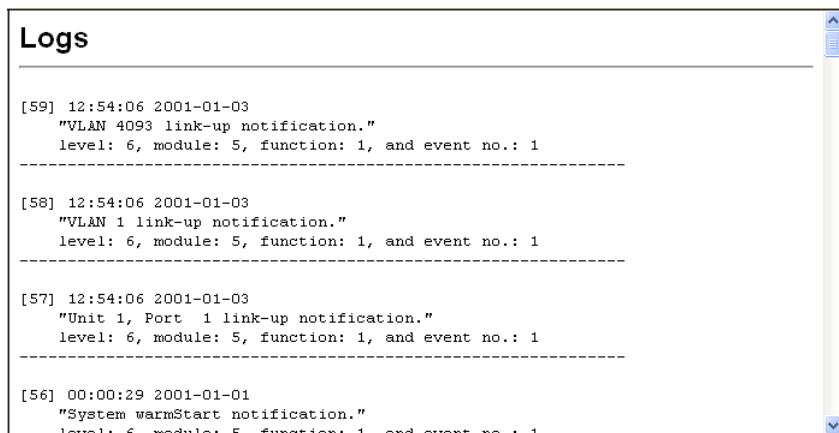
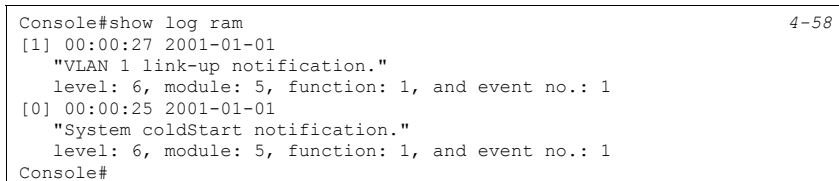

Figure 3-16 Displaying Logs

CLI – This example shows the event message stored in RAM.



System Log Configuration

The system allows you to enable or disable event logging, and specify which levels are logged to RAM or flash memory.

Severe error messages that are logged to flash memory are permanently stored in the switch to assist in troubleshooting network problems. Up to 4096 log entries can be stored in the flash memory, with the oldest entries being overwritten first when the available log memory (256 kilobytes) has been exceeded.

The System Logs page allows you to configure and limit system messages that are logged to flash or RAM memory. The default is for event levels 0 to 3 to be logged to flash and levels 0 to 6 to be logged to RAM.

Command Attributes

- **System Log Status** – Enables/disables the logging of debug or error messages to the logging process. (Default: Enabled)
- **Flash Level** – Limits log messages saved to the switch's permanent flash memory for all levels up to the specified level. For example, if level 3 is specified, all messages from level 0 to level 3 will be logged to flash. (Range: 0-7, Default: 3)

Table 3-3 Logging Levels

Level	Severity Name	Description
7	Debug	Debugging messages
6	Informational	Informational messages only
5	Notice	Normal but significant condition, such as cold start
4	Warning	Warning conditions (e.g., return false, unexpected return)
3	Error	Error conditions (e.g., invalid input, default used)
2	Critical	Critical conditions (e.g., memory allocation, or free memory error - resource exhausted)
1	Alert	Immediate action needed
0	Emergency	System unusable

* There are only Level 2, 5 and 6 error messages for the current firmware release.

- **RAM Level** – Limits log messages saved to the switch's temporary RAM memory for all levels up to the specified level. For example, if level 7 is specified, all messages from level 0 to level 7 will be logged to RAM. (Range: 0-7, Default: 6)

Note: The Flash Level must be equal to or less than the RAM Level.

Web – Click System, Log, System Logs. Specify System Log Status, set the level of event messages to be logged to RAM and flash memory, then click Apply.

System Logs

System Log Status	<input checked="" type="checkbox"/> Enabled
Flash Level (0-7)	<input type="text" value="0"/>
Ram Level (0-7)	<input type="text" value="0"/>

Figure 3-17 System Logs

3 Configuring the Switch

CLI – Enable system logging and then specify the level of messages to be logged to RAM and flash memory. Use the **show logging** command to display the current settings.

```
Console(config)#logging on 4-54
Console(config)#logging history ram 0 4-55
Console(config)#end
Console#show logging flash 4-58
Syslog logging: Enabled
History logging in FLASH: level emergencies
Console#
```

Remote Log Configuration

The Remote Logs page allows you to configure the logging of messages that are sent to syslog servers or other management stations. You can also limit the error messages sent to only those messages below a specified level.

Command Attributes

- **Remote Log Status** – Enables/disables the logging of debug or error messages to the remote logging process. (Default: Enabled)
- **Logging Facility** – Sets the facility type for remote logging of syslog messages. There are eight facility types specified by values of 16 to 23. The facility type is used by the syslog server to dispatch log messages to an appropriate service. The attribute specifies the facility type tag sent in syslog messages. (See RFC 3164.) This type has no effect on the kind of messages reported by the switch. However, it may be used by the syslog server to process messages, such as sorting or storing messages in the corresponding database. (Range: 16-23, Default: 23)
- **Logging Trap** – Limits log messages that are sent to the remote syslog server for all levels up to the specified level. For example, if level 3 is specified, all messages from level 0 to level 3 will be sent to the remote server. (Range: 0-7, Default: 6)
- **Host IP List** – Displays the list of remote server IP addresses that receive the syslog messages. The maximum number of host IP addresses allowed is five.
- **Host IP Address** – Specifies a new server IP address to add to the Host IP List.

Web – Click System, Log, Remote Logs. To add an IP address to the Host IP List, type the new IP address in the Host IP Address box, and then click Add. To delete an IP address, click the entry in the Host IP List, and then click Remove.

Remote Logs

Remote Log Status	<input checked="" type="checkbox"/> Enabled
Logging Facility (16-23)	<input type="text" value="23"/>
Logging Trap (0-7)	<input type="text" value="6"/>

Host IP Address:

Current: **New:**

Host IP List
 (none)

Host IP Address

Figure 3-18 Remote Logs

CLI – Enter the syslog server host IP address, choose the facility type and set the logging trap.

```

Console(config)#logging host 192.168.1.15           4-56
Console(config)#logging facility 23                4-56
Console(config)#logging trap 4                     4-57
Console(config)#end
Console#show logging trap                           4-57
Syslog logging:                                     Enabled
REMOTELOG status:                                  Enabled
REMOTELOG facility type:                           local use 7
REMOTELOG level type:                               Warning conditions
REMOTELOG server ip address: 192.168.1.15
REMOTELOG server ip address: 0.0.0.0
REMOTELOG server ip address: 0.0.0.0
REMOTELOG server ip address: 0.0.0.0
REMOTELOG server ip address: 0.0.0.0
Console#
  
```

Simple Mail Transfer Protocol

SMTP (Simple Mail Transfer Protocol) is used to send email messages between servers. The messages can be retrieved using POP or IMAP clients.

Command Attributes

- **Admin Status** – Enables/disables the SMTP function. (Default: Enabled)
- **Email Source Address** – This command specifies SMTP servers email addresses that can send alert messages.
- **Severity** – Specifies the degree of urgency that the message carries.

3 Configuring the Switch

- Debugging – Sends a debugging notification. (Level 7)
 - Information – Sends informatative notification only. (Level 6)
 - Notice – Sends notification of a normal but significant condition, such as a cold start. (Level 5)
 - Warning – Sends notification of a warning condition such as return false, or unexpected return. (Level 4)
 - Error – Sends notification that an error conditions has occurred, such as invalid input, or default used. (Level 3)
 - Critical – Sends notification that a critical condition has occurred, such as memory allocation, or free memory error - resource exhausted. (Level 2)
 - Alert – Sends urgent notification that immediate action must be taken. (Level 1)
 - Emergency – Sends an emergency notification that the system is now unusable. (Level 0)
- **SMTP Server List** – Specifies a list of recipient SMTP servers.
 - **SMTP Server** – Specifies a new SMTP server address to add to the SMTP Server List.
 - **Email Destination Address List** – Specifies a list of recipient Email Destination Address.
 - **Email Destination Address** – This command specifies SMTP servers that may receive alert messages.

Web – Click System, Log, SMTP. To add an IP address to the Server IP List, type the new IP address in the Server IP Address box, and then click Add. To delete an IP address, click the entry in the Server IP List, and then click Remove.

SMTP

Admin Status	<input checked="" type="checkbox"/> Enabled
Email Source Address	<input type="text"/>
Severity	7 - Debugging ▾

SMTP Server List New:

(none)	<input type="button" value="Add"/>	SMTP Server: <input type="text"/>
	<input type="button" value="Remove"/>	

Email Destination Address List: New:

(none)	<input type="button" value="Add"/>	Email Destination Address: <input type="text"/>
	<input type="button" value="Remove"/>	

Figure 3-19 Enabling and Configuring SMTP

CLI – Enter the host ip address, followed by the mail severity level, source and destination email addresses and enter the sendmail command to complete the action. Use the show logging command to display SMTP information.

```
Console(config)#logging sendmail host 192.168.1.19
Console(config)#logging sendmail level 3
Console(config)#logging sendmail source-email
bill@this-company.com
Console(config)#logging sendmail destination-email
ted@this-company.com
Console(config)#logging sendmail
Console#
```

Resetting the System

This feature restarts the system. You can reboot the system immediately, or you can configure the switch to reset after a specified amount of time.

Command Attributes

- **Hours** – Specifies the amount of hours to wait, combined with the minutes, before the switch resets. (Range: 0-576; Default: 0)
- **Minutes** – Specifies the amount of minutes to wait, combined with the hours, before the switch resets. (Range: 1-34560; Default: 0)
- **Reset** – Resets the switch after the specified time. If the hour and minute fields are blank, then the switch will reset immediately.
- **Refresh** – Refreshes the countdown timer of a pending delayed reset.
- **Cancel** – Cancels a pending delayed reset.

Web – Click System, Reset. Enter the amount of time the switch should wait before rebooting. Click the Reset button to reboot the switch or click the Cancel button to cancel a configured reset. If prompted, confirm that you want reset the switch or cancel a configured reset.

Reset Settings

Note: The specified time must be equal to or less than 24 days.

Reload switch in hours minutes.

No configured settings for reloading.

Figure 3-20 Resetting the System

3 Configuring the Switch

CLI – Use the **reload** command to restart the switch. When prompted, confirm that you want to reset the switch.

```
Console#reload 4-23  
System will be restarted, continue <y/n>? y
```

Note: When restarting the system, it will always run the Power-On Self-Test. It will also retain all configuration information stored in non-volatile memory (See “Saving or Restoring Configuration Settings” on page 3-21 or the **copy running-config startup-config** command (See “copy” on page 4-84)).

Setting the System Clock

Simple Network Time Protocol (SNTP) allows the switch to set its internal clock based on periodic updates from a time server (SNTP or NTP). Maintaining an accurate time on the switch enables the system log to record meaningful dates and times for event entries. You can also manually set the clock. If the clock is not set, the switch will only record the time from the factory default set at the last bootup.

When the SNTP client is enabled, the switch periodically sends a request for a time update to a configured time server. You can configure up to three time server IP addresses. The switch will attempt to poll each server in the configured sequence.

Setting the Time Manually

You can set the system time on the switch manually without using SNTP.

CLI – This example sets the system clock time and then displays the current time and date

```
Console#calendar set 17 46 00 october 18 2007 4-76  
Console#show calendar 4-76  
17:46:11 October 18 2007  
Console#
```

Configuring SNTP

You can configure the switch to send time synchronization requests to time servers.

Command Attributes

- **SNTP Client** – Configures the switch to operate as an SNTP client. This requires at least one time server to be specified in the SNTP Server field. (Default: Disabled)
- **SNTP Poll Interval** – Sets the interval between sending requests for a time update from a time server. (Range: 16-16384 seconds; Default: 16 seconds)
- **SNTP Server** – Sets the IP address for up to three time servers. The switch attempts to update the time from the first server, if this fails it attempts an update from the next server in the sequence.

Web – Select SNTP, Configuration. Modify any of the required SNTP parameters, and click Apply.

SNTP Configuration			
SNTP Client	<input checked="" type="checkbox"/> Enabled		
SNTP Polling Interval (16-16384)	60		
SNTP Server	10.1.0.19	137.82.140.80	128.250.36.2

Figure 3-21 SNTP Configuration

CLI – This example configures the switch to operate as an SNTP unicast client and then displays the current time and settings.

```

Console(config)#sntp server 10.1.0.19 137.82.140.80 128.250.36.2      4-65
Console(config)#sntp poll 60                                         4-66
Console(config)#sntp client                                          4-64
Console(config)#exit
Console#show sntp
Current time: Jan 6 14:56:05 2004
Poll interval: 60
Current mode: unicast
SNTP status : Enabled
SNTP server 10.1.0.19 137.82.140.80 128.250.36.2
Current server: 128.250.36.2
Console#

```

Configuring NTP

The NTP client allows you to configure up to 50 NTP servers to poll for time updates. You can also enable authentication to ensure that reliable updates are received from only authorized NTP servers. The authentication keys and their associated key number must be centrally managed and manually distributed to NTP servers and clients. The key numbers and key values must match on both the server and client.

Command Attributes

- **NTP Client** – Configures the switch to operate as an NTP client. This requires at least one time server to be specified in the NTP Server list. (Default: Disabled)
- **NTP Polling Interval** – Sets the interval between sending requests for a time update from NTP servers. (Range: 16-16384 seconds; Default: 16 seconds)
- **NTP Authenticate** – Enables authentication for time requests and updates between the switch and NTP servers. (Default: Disabled)
- **NTP Server** – Sets the IP address for an NTP server to be polled. The switch requests an update from all configured servers, then determines the most accurate time update from the responses received.

3 Configuring the Switch

- **Version** – Specifies the NTP version supported by the server. (Range: 1-3; Default: 3)
- **Authenticating Key** – Specifies the number of the key in the NTP Authentication Key List to use for authentication with the configured server. The authentication key must match the key configured on the NTP server.
- **Key Number** – A number that specifies a key value in the NTP Authentication Key List. Up to 255 keys can be configured in the NTP Authentication Key List. Note that key numbers and values must match on both the server and client. (Range: 1-65535)
- **Key Context** – Specifies an MD5 authentication key string. The key string can be up to 32 case-sensitive printable ASCII characters (no spaces).

Web – Select SNTP, Configuration. Modify any of the required NTP parameters, and click Apply.

The screenshot displays the 'NTP Configuration' web interface. It is divided into three main sections:

- NTP Client:** A table with two rows: 'NTP Client' with a checked 'Enabled' checkbox, and 'NTP Polling Interval (16-16384)' with a text input field containing '16'. Below this is 'NTP Authenticate' with a checked 'Enabled' checkbox.
- NTP Server List:** A list box on the left contains IP addresses: '10.1.2.19 3 9', '128.250.36.2 2 1', '137.182.140.80 3 23', and '192.168.1.19 3 23'. To the right are '<< Add' and 'Remove' buttons. Further right is a 'New:' section with three input fields: 'NTP Server', 'Version <1-3>', and 'Authenticate Key'.
- NTP Authentication Key List:** A list box on the left contains key strings: '1 6P71O17S56P177N5152O34S5', '9 CL1414259572U81Q1618', and '23 42M141428U677Q17'. To the right are '<< Add' and 'Remove' buttons. Further right is a 'New:' section with two input fields: 'Key Number' and 'Key Context'.

Figure 3-22 NTP Client Configuration

CLI – This example configures the switch to operate as an NTP client and then displays the current settings.

```

Console(config)#ntp authentication-key 19 md5 thisiskey19      4-70
Console(config)#ntp authentication-key 30 md5 ntpkey30
Console(config)#ntp server 192.168.3.20                      4-68
Console(config)#ntp server 192.168.3.21
Console(config)#ntp server 192.168.4.22 version 2
Console(config)#ntp server 192.168.5.23 version 3 key 19
Console(config)#ntp poll 60                                  4-69
Console(config)#ntp client                                  4-67
Console(config)#ntp authenticate                             4-69
Console(config)#exit
Console#show ntp                                             4-71
Current time: Jan  1 02:58:58 2001
Poll interval: 60
Current mode: unicast
NTP status : Enabled          NTP Authenticate status : Enabled
Last Update NTP Server: 0.0.0.0      Port: 0
Last Update time: Dec 31 00:00:00 2000 UTC
NTP Server 192.168.3.20 version 3
NTP Server 192.168.3.21 version 3
NTP Server 192.168.4.22 version 2
NTP Server 192.168.5.23 version 3 key 19
NTP Authentication-Key 19 md5 Q33016Q6338241J022S29Q731K7 7
NTP Authentication-Key 30 md5 D2V8777I51K1132K3552L26R614104 7
Console#

```

Setting the Time Zone

SNTP uses Coordinated Universal Time (or UTC, formerly Greenwich Mean Time, or GMT) based on the time at the Earth's prime meridian, zero degrees longitude, which passes through Greenwich, England. To display a time corresponding to your local time, you must indicate the number of hours and minutes your time zone is east (before) or west (after) of UTC. You can choose one of the 80 predefined time zone definitions, or you can manually configure the parameters for your local time zone.

Command Attributes

- **Predefined Configuration** – A drop-down box provides access to the 80 predefined time zone configurations. Each choice indicates its offset from UTC and lists at least one major city or location covered by the time zone.
- **User-defined Configuration** – Allows the user to define all parameters of the local time zone.
 - **Direction**: Configures the time zone to be before (east) or after (west) UTC.
- **Name** – Assigns a name to the time zone. (Range: 1-29 characters)
- **Hours (0-13)** – The number of hours before/after UTC. The maximum value before UTC is 12. The maximum value after UTC is 13.
- **Minutes (0-59)** – The number of minutes before/after UTC.

3 Configuring the Switch

Web – Select SNTP, Clock Time Zone. Set the offset for your time zone relative to the UTC using either a predefined or custom definition, and click Apply.

Time Zone

Predefined Configuration

Time Zone:

User-defined Configuration

Note: The maximum value before UTC is 12:00.
The maximum value after UTC is 13:00.

Direction	<input type="radio"/> Before UTC <input checked="" type="radio"/> After UTC
Name	<input type="text" value="UTC"/>
Hours (0-13)	<input type="text" value="0"/>
Minutes (0-59)	<input type="text" value="0"/>

Figure 3-23 Setting the System Clock

CLI - This example shows how to set the time zone for the system clock using one of the predefined time zone configurations.

```
Console(config)#clock timezone-predefined GMT-0930-Taiohae      4-71
Console(config)#
```

Simple Network Management Protocol

SNMP is a communication protocol designed specifically for managing devices on a network. Equipment commonly managed with SNMP includes switches, routers and host computers. SNMP is typically used to configure these devices for proper operation in a network environment, as well as to monitor them to evaluate performance or detect potential problems.

Managed devices supporting SNMP contain software, which runs locally on the device and is referred to as an agent. A defined set of variables, known as managed objects, is maintained by the SNMP agent and used to manage the device. These objects are defined in a Management Information Base (MIB) that provides a standard presentation of the information controlled by the agent. SNMP defines both the format of the MIB specifications and the protocol used to access this information over the network.

The switch includes an onboard agent that supports SNMP versions 1, 2c, and 3. This agent continuously monitors the status of the switch hardware, as well as the traffic passing through its ports. A network management station can access this information using software such as HP OpenView. Access to the onboard agent from clients using SNMP v1 and v2c is controlled by community strings. To communicate with the switch, the management station must first submit a valid community string for authentication.

Access to the switch using from clients using SNMPv3 provides additional security features that cover message integrity, authentication, and encryption; as well as controlling user access to specific areas of the MIB tree.

The SNMPv3 security structure consists of security models, with each model having it's own security levels. There are three security models defined, SNMPv1, SNMPv2c, and SNMPv3. Users are assigned to "groups" that are defined by a security model and specified security levels. Each group also has a defined security access to set of MIB objects for reading and writing, which are known as "views." The switch has a default view (all MIB objects) and default groups defined for security models v1 and v2c. The following table shows the security models and levels available and the system default settings.

Table 3-4 SNMPv3 Security Models and Levels

Model	Level	Group	Read View	Write View	Notify View	Security
v1	noAuthNoPriv	public (read only)	defaultview	none	none	Community string only
v1	noAuthNoPriv	private (read/write)	defaultview	defaultview	none	Community string only
v1	noAuthNoPriv	<i>user defined</i>	<i>user defined</i>	<i>user defined</i>	<i>user defined</i>	Community string only
v2c	noAuthNoPriv	public (read only)	defaultview	none	none	Community string only
v2c	noAuthNoPriv	private (read/write)	defaultview	defaultview	none	Community string only
v2c	noAuthNoPriv	<i>user defined</i>	<i>user defined</i>	<i>user defined</i>	<i>user defined</i>	Community string only
v3	noAuthNoPriv	<i>user defined</i>	<i>user defined</i>	<i>user defined</i>	<i>user defined</i>	A user name match only
v3	AuthNoPriv	<i>user defined</i>	<i>user defined</i>	<i>user defined</i>	<i>user defined</i>	Provides user authentication via MD5 or SHA algorithms
v3	AuthPriv	<i>user defined</i>	<i>user defined</i>	<i>user defined</i>	<i>user defined</i>	Provides user authentication via MD5 or SHA algorithms and data privacy using DES 56-bit encryption

Note: The predefined default groups and view can be deleted from the system. You can then define customized groups and views for the SNMP clients that require access.

Setting Community Access Strings

You may configure up to five community strings authorized for management access. All community strings used for IP Trap Managers should be listed in this table. For security reasons, you should consider removing the default strings.

Command Attributes

- **SNMP Community Capability** – Indicates that the switch supports up to five community strings.
- **Community String** – A community string that acts like a password and permits access to the SNMP protocol.
Default strings: “public” (read-only), “private” (read/write)
Range: 1-32 characters, case sensitive
- **Access Mode**
 - **Read-Only** – Specifies read-only access. Authorized management stations are only able to retrieve MIB objects.
 - **Read/Write** – Specifies read-write access. Authorized management stations are able to both retrieve and modify MIB objects.

Web – Click SNMP, Configuration. Add new community strings as required, select the access rights from the Access Mode drop-down list, then click Add.



Figure 3-24 Configuring SNMP Community Strings

CLI – The following example adds the string “spiderman” with read/write access.

```
Console(config)#snmp-server community spiderman rw 4-151
Console(config)#
```

Specifying Trap Managers and Trap Types

Traps indicating status changes are issued by the switch to specified trap managers. You must specify trap managers so that key events are reported by this switch to your management station (using network management platforms such as HP OpenView). You can specify up to five management stations that will receive authentication failure messages and other trap messages from the switch.

Command Attributes

- **Trap Manager Capability** – This switch supports up to five trap managers.
- **Current** – Displays a list of the trap managers currently configured.
- **Trap Manager IP Address** – IP address of the host (the targeted recipient).
- **Trap Manager Community String** – Community string sent with the notification operation. (Range: 1-32 characters, case sensitive)
- **Trap UDP Port** – Sets the UDP port number. (Default: 162)
- **Trap Version** – Specifies whether to send notifications as SNMP v1, v2c, or v3 traps. (The default is version 1.)
- **Trap Security Level** – Specifies the security level.
- **Enable Authentication Traps** – Issues a trap message whenever an invalid community string is submitted during the SNMP access authentication process. (Default: Enabled)
- **Enable Link-up and Link-down Traps** – Issues a trap message whenever a port link is established or broken. (Default: Enabled)

Web – Click SNMP, Configuration. Fill in the IP address and community string for each trap manager that will receive trap messages, and then click Add. Select the trap types required using the check boxes for Authentication and Link-up/down traps, and then click Apply.

Trap Managers:

Trap Manager Capability: 5

Current: (none) New:

Trap Manager IP Address	<input type="text"/>
Trap Manager Community String	<input type="text"/>
Trap UDP Port	<input type="text" value="162"/>
Trap Version	<input type="text" value="1"/>
Trap Security Level	<input type="text" value="noAuthNoPriv"/>
<input type="checkbox"/> Trap Inform	Timeout (0-2147483647) <input type="text" value="(1/100 secs)"/> (1/100 secs)
	Retry times (0-255) <input type="text"/>

Enable Authentication Traps:
 Enable Link-up and Link-down Traps:

Figure 3-25 Configuring IP Trap Managers

CLI – This example adds a trap manager and enables both authentication and link-up, link-down traps.

```

Console(config)#snmp-server host 192.168.1.19 private version 2c 4-153
Console(config)#snmp-server enable traps 4-155
  
```

Enabling SNMP Agent Status

Enables SNMPv3 service for all management clients (i.e., versions 1, 2c, 3).

Command Attributes

- **SNMP Agent Status** – Check the box to enable or disable the SNMP Agent.

Web – Click SNMP, Agent Status.

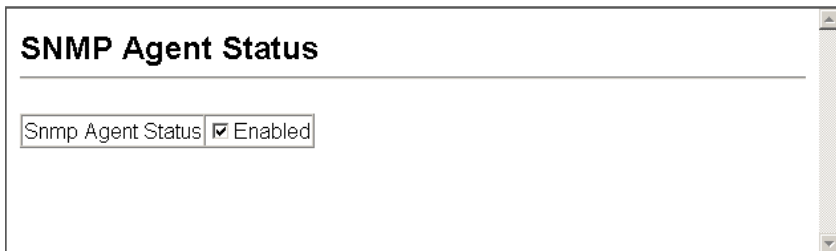

Figure 3-26 Enabling SNMP Agent Status

Configuring SNMPv3 Management Access

To configure SNMPv3 management access to the switch, follow these steps:

1. If you want to change the default engine ID, it must be changed first before configuring other parameters.
2. Specify read and write access views for the switch MIB tree.
3. Configure SNMP user groups with the required security model (i.e., SNMP v1, v2c or v3) and security level (i.e., authentication and privacy).
4. Assign SNMP users to groups, along with their specific authentication and privacy passwords.

Setting the Local Engine ID

An SNMPv3 engine is an independent SNMP agent that resides on the switch. This engine protects against message replay, delay, and redirection. The engine ID is also used in combination with user passwords to generate the security keys for authenticating and encrypting SNMPv3 packets.

A local engine ID is automatically generated that is unique to the switch. This is referred to as the default engine ID. If the local engine ID is deleted or changed, all SNMP users will be cleared. You will need to reconfigure all existing users.

A new engine ID can be specified by entering 9 to 64 hexadecimal characters (5 to 32 octets in hexadecimal format). If an odd number of characters are specified, a trailing zero is added to the value to fill in the last octet. For example, the value “123456789” is equivalent to “1234567890”.

Web – Click SNMP, SNMPv3, Engine ID.

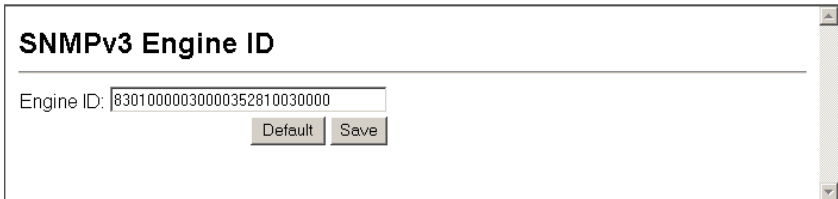

SNMPv3 Engine ID

Engine ID:

Figure 3-27 Setting an Engine ID

Specifying a Remote Engine ID

To send inform messages to an SNMPv3 user on a remote device, you must first specify the engine identifier for the SNMP agent on the remote device where the user resides. The remote engine ID is used to compute the security digest for authenticating and encrypting packets sent to a user on the remote host.

SNMP passwords are localized using the engine ID of the authoritative agent. For informs, the authoritative SNMP agent is the remote agent. You therefore need to configure the remote agent's SNMP engine ID before you can send proxy requests or informs to it.

The engine ID can be specified by entering 9 to 64 hexadecimal characters (5 to 32 octets in hexadecimal format). If an odd number of characters are specified, a trailing zero is added to the value to fill in the last octet. For example, the value "123456789" is equivalent to "1234567890".

Web – Click SNMP, SNMPv3, Remote Engine ID.

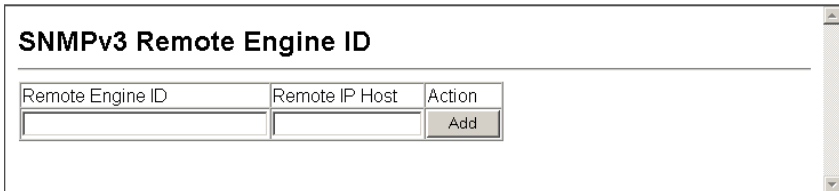

Remote Engine ID	Remote IP Host	Action
<input type="text"/>	<input type="text"/>	Add

Figure 3-28 Setting a Remote Engine ID

Configuring SNMPv3 Users

Each SNMPv3 user is defined by a unique name. Users must be configured with a specific security level and assigned to a group. The SNMPv3 group restricts users to a specific read, write, and notify view.

Command Attributes

- **User Name** – The name of user connecting to the SNMP agent.
(Range: 1-32 characters)
- **Group Name** – The name of the SNMP group to which the user is assigned.
(Range: 1-32 characters)
- **Model** – The user security model; SNMP v1, v2c or v3.
- **Level** – The security level used for the user:
 - **noAuthNoPriv** – There is no authentication or encryption used in SNMP communications. (This is the default for SNMPv3.)
 - **AuthNoPriv** – SNMP communications use authentication, but the data is not encrypted (only available for the SNMPv3 security model).
 - **AuthPriv** – SNMP communications use both authentication and encryption (only available for the SNMPv3 security model).
- **Authentication** – The method used for user authentication.
(Options: MD5, SHA; Default: MD5)

- **Authentication Password** – A minimum of eight plain text characters is required.
- **Privacy** – The encryption algorithm use for data privacy; only 56-bit DES is currently available.
- **Actions** – Enables the user to be assigned to another SNMPv3 group.

Web – Click SNMP, SNMPv3, Users. Click New to configure a user name. In the New User page, define a name and assign it to a group, then click Add to save the configuration and return to the User Name list. To delete a user, check the box next to the user name, then click Delete. To change the assigned group of a user, click Change Group in the Actions column of the users table and select the new group.

SNMPv3 Users

New... Delete

	User Name	Group Name	Model	Level	Authentication	Privacy	Actions
<input type="checkbox"/>	Matt	public	V1	noAuthNoPriv	None	None	Change Group...

SNMPv3 Users -- New

SNMPv3 User:

User Name:

Group Name: public

Security Model: V1

Security Level: noAuthNoPriv

User Authentication:

Authentication Protocol: MD5

Authentication Password:

Data Privacy:

Privacy Protocol: DES56

Privacy Password:

Back Add

SNMPv3 Users -- Edit

User Name: Matt

Group Name: public

Back Change

Figure 3-29 Configuring SNMPv3 Users

Configuring Remote SNMPv3 Users

Each SNMPv3 user is defined by a unique name. Users must be configured with a specific security level and assigned to a group. The SNMPv3 group restricts users to a specific read, write, and notify view.

To send inform messages to an SNMPv3 user on a remote device, you must first specify the engine identifier for the SNMP agent on the remote device where the user resides. The remote engine ID is used to compute the security digest for authenticating and encrypting packets sent to a user on the remote host.

Command Attributes

- **User Name** – The name of user connecting to the SNMP agent.
(Range: 1-32 characters)
- **Group Name** – The name of the SNMP group to which the user is assigned.
(Range: 1-32 characters)
- **Engine ID** – The engine identifier for the SNMP agent on the remote device where the remote user resides. Note that the remote engine identifier must be specified before you configure a remote user. (See “Specifying a Remote Engine ID” on page 44.)
- **Model** – The user security model; SNMP v1, v2c or v3.
- **Level** – The security level used for the user:
 - **noAuthNoPriv** – There is no authentication or encryption used in SNMP communications. (This is the default for SNMPv3.)
 - **AuthNoPriv** – SNMP communications use authentication, but the data is not encrypted (only available for the SNMPv3 security model).
 - **AuthPriv** – SNMP communications use both authentication and encryption (only available for the SNMPv3 security model).
- **Authentication** – The method used for user authentication.
(Options: MD5, SHA; Default: MD5)
- **Privacy** – The encryption algorithm use for data privacy; only 56-bit DES is currently available.

Web – Click SNMP, SNMPv3, Remote Users. Click New to configure a user name. In the New User page, define a name and assign it to a group, then click Add to save the configuration and return to the User Name list. To delete a user, check the box next to the user name, then click Delete.

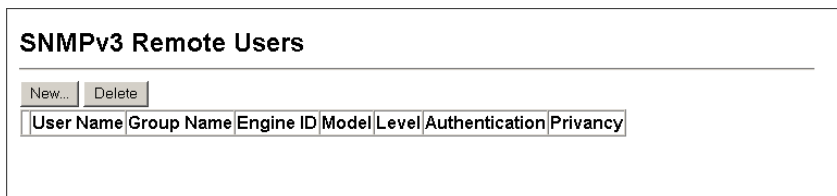

User Name	Group Name	Engine ID	Model	Level	Authentication	Privacy
-----------	------------	-----------	-------	-------	----------------	---------

Figure 3-30 Configuring Remote SNMPv3 Users

Configuring SNMPv3 Groups

An SNMPv3 group sets the access policy for its assigned users, restricting them to specific read, write, and notify views. You can use the pre-defined default groups or create new groups to map a set of SNMP users to SNMP views.

Command Attributes

- **Group Name** – The name of the SNMP group to which the user is assigned. (Range: 1-32 characters)
- **Model** – The user security model; SNMP v1, v2c or v3.
- **Level** – The security level used for the group:
 - **noAuthNoPriv** – There is no authentication or encryption used in SNMP communications. (This is the default for SNMPv3.)
 - **AuthNoPriv** – SNMP communications use authentication, but the data is not encrypted (only available for the SNMPv3 security model).
 - **AuthPriv** – SNMP communications use both authentication and encryption (only available for the SNMPv3 security model).
- **Read View** – The configured view for read access. (Range: 1-64 characters)
- **Write View** – The configured view for write access. (Range: 1-64 characters)
- **Notify View** – The configured view for notifications. (Range: 1-64 characters)

Table 3-5 Supported Notification Messages

Object Label	Object ID	Description
<i>RFC 1493 Traps</i>		
newRoot	1.3.6.1.2.1.17.0.1	The newRoot trap indicates that the sending agent has become the new root of the Spanning Tree; the trap is sent by a bridge soon after its election as the new root, e.g., upon expiration of the Topology Change Timer immediately subsequent to its election.
topologyChange	1.3.6.1.2.1.17.0.2	A topologyChange trap is sent by a bridge when any of its configured ports transitions from the Learning state to the Forwarding state, or from the Forwarding state to the Discarding state. The trap is not sent if a newRoot trap is sent for the same transition.
<i>SNMPv2 Traps</i>		
coldStart	1.3.6.1.6.3.1.1.5.1	A coldStart trap signifies that the SNMPv2 entity, acting in an agent role, is reinitializing itself and that its configuration may have been altered.
warmStart	1.3.6.1.6.3.1.1.5.2	A warmStart trap signifies that the SNMPv2 entity, acting in an agent role, is reinitializing itself such that its configuration is unaltered.

Table 3-5 Supported Notification Messages (Continued)

Object Label	Object ID	Description
linkDown ^a	1.3.6.1.6.3.1.1.5.3	A linkDown trap signifies that the SNMP entity, acting in an agent role, has detected that the ifOperStatus object for one of its communication links is about to enter the down state from some other state (but not from the notPresent state). This other state is indicated by the included value of ifOperStatus.
linkUp	1.3.6.1.6.3.1.1.5.4	A linkUp trap signifies that the SNMP entity, acting in an agent role, has detected that the ifOperStatus object for one of its communication links left the down state and transitioned into some other state (but not into the notPresent state). This other state is indicated by the included value of ifOperStatus.
authenticationFailure	1.3.6.1.6.3.1.1.5.5	An authenticationFailure trap signifies that the SNMPv2 entity, acting in an agent role, has received a protocol message that is not properly authenticated. While all implementations of the SNMPv2 must be capable of generating this trap, the snmpEnableAuthenTraps object indicates whether this trap will be generated.
<i>RMON Events (V2)</i>		
risingAlarm	1.3.6.1.2.1.16.0.1	The SNMP trap that is generated when an alarm entry crosses its rising threshold and generates an event that is configured for sending SNMP traps.
fallingAlarm	1.3.6.1.2.1.16.0.2	The SNMP trap that is generated when an alarm entry crosses its falling threshold and generates an event that is configured for sending SNMP traps.
<i>Private Traps</i>		
swPowerStatus Change Trap	1.3.6.1.4.1.11863.1.1.59.2.1.0.1	This trap is sent when the power state changes.
swIpFilterRejectTrap	1.3.6.1.4.1.11863.1.1.59.2.1.0.40	This trap is sent when an incorrect IP address is rejected by the IP Filter.

a. These are legacy notifications and therefore must be enabled in conjunction with the corresponding traps on the SNMP Configuration menu.

Web – Click SNMP, SNMPv3, Groups. Click New to configure a new group. In the New Group page, define a name, assign a security model and level, and then select read and write views. Click Add to save the new group and return to the Groups list. To delete a group, check the box next to the group name, then click Delete.

SNMPv3 Groups

	Group Name	Model	Level	Read View	Write View	Notify View
<input type="checkbox"/>	public	V1	noAuthNoPriv	defaultview	none	none
<input type="checkbox"/>	public	V2C	noAuthNoPriv	defaultview	none	none
<input type="checkbox"/>	private	V1	noAuthNoPriv	defaultview	defaultview	none
<input type="checkbox"/>	private	V2C	noAuthNoPriv	defaultview	defaultview	none

SNMPv3 Groups -- New

Group Properties:

Group Name:

Security Model:

Security Level:

SNMPv3 Views:

Read View:

Write View:

Notify View:

Figure 3-31 Configuring SNMPv3 Groups

Setting SNMPv3 Views

SNMPv3 views are used to restrict user access to specified portions of the MIB tree. The predefined view “defaultview” includes access to the entire MIB tree.

Command Attributes

- **View Name** – The name of the SNMP view. (Range: 1-64 characters)
- **View OID Subtrees** – Shows the currently configured object identifiers of branches within the MIB tree that define the SNMP view.
- **Edit OID Subtrees** – Allows you to configure the object identifiers of branches within the MIB tree. Wild cards can be used to mask a specific portion of the OID string.

3 Configuring the Switch

- **Type** – Indicates if the object identifier of a branch within the MIB tree is included or excluded from the SNMP view.

Web – Click SNMP, SNMPv3, Views. Click New to configure a new view. In the New View page, define a name and specify OID subtrees in the switch MIB to be included or excluded in the view. Click Back to save the new view and return to the SNMPv3 Views list. For a specific view, click on View OID Subtrees to display the current configuration, or click on Edit OID Subtrees to make changes to the view settings. To delete a view, check the box next to the view name, then click Delete.

The figure illustrates the configuration process for SNMPv3 Views through three sequential panels:

- SNMPv3 Views**: The main management page. It features a 'New...' button and a 'Delete' button. Below is a table with columns for Name, OID Subtrees, and Actions. The 'defaultview' entry is shown with a checkbox, a link to 'View OID Subtrees', and a link to 'Edit OID Subtrees...'. Arrows indicate navigation from this table to the 'View' and 'Edit' panels.
- SNMPv3 Views -- View**: A detailed view of the 'defaultview'. It shows 'View : defaultview' and a table with columns 'OID Subtree' and 'Type'. The table contains one entry: '1' with 'Included' type. A 'Back' button is located below the table.
- SNMPv3 View -- Edit**: The configuration page for editing the 'defaultview'. It shows 'View Name: defaultview' and 'Current:' with a list containing '1 (Included)'. There are '<< Add' and 'Remove' buttons. The 'New:' section has an 'OID Subtree' input field, a 'Type' dropdown menu set to 'Included', and a 'Back' button.

Figure 3-32 Configuring SNMPv3 Views

User Authentication

You can configure this switch to authenticate users logging into the system for management access using local or remote authentication methods. Port-based authentication using IEEE 802.1X can also be configured to control either

management access to the uplink ports or client access to the data ports. This switch provides secure network management access using the following options:

- **User Accounts** – Manually configures management access rights for users.
- **Authentication Settings** – Uses remote authentication to configure access rights.
- **AAA** – Enables accounting of requested services for billing or security purposes.
- **HTTPS Settings** – Provides a secure web connection.
- **SSH Settings** – Provides a secure shell (for secure Telnet access).
- **802.1X** – Uses IEEE 802.1X port authentication to control access to specific ports.
- **IP Filter** – Filters management access to the web, SNMP or Telnet interface.
- **Port Security** – Configures notification and automatic shutdown options for ports.

Configuring User Accounts

The guest only has read access for most configuration parameters. However, the administrator has write access for all parameters governing the onboard agent. You should therefore assign a new administrator password as soon as possible, and store it in a safe place.

The default guest name is “guest” with the password “guest.” The default administrator name is “admin” with the password “admin.”

Command Attributes

- **Account List** – Displays the current list of user accounts and associated access levels. (Defaults: admin, and guest)
- **New Account** – Displays configuration settings for a new account.
 - **User Name** – The name of the user.
(Maximum length: 8 characters; maximum number of users: 16)
 - **Access Level** – Specifies the user level.
(Options: Normal and Privileged)
 - **Password** – Specifies the user password.
(Range: 0-8 characters plain text, case sensitive)
- **Change Password** – Sets a new password for the specified user name.
- **Add/Remove** – Adds or removes an account from the list.

3 Configuring the Switch

Web – Click Security, User Accounts. To configure a new user account, specify a user name, select the user's access level, then enter a password and confirm it. Click Add to save the new user account and add it to the Account List. To change the password for a specific user, enter the user name and new password, confirm the password by entering it again, then click Apply.

User Accounts

Account List

admin (Privileged)
guest (Normal)

<< Add Remove

New Account

User Name	bob
Access Level	Normal
Password	Aa000000
Confirm Password	Aa000000

Change Password

User Name	
New Password	
Confirm Password	

Change

Figure 3-33 Access Levels

CLI – Assign a user name to access-level 15 (i.e., administrator), then specify the password.

```
Console(config)#username bob access-level 15  
Console(config)#username bob password 0 smith  
Console(config)#
```

4-37

Configuring Local/Remote Logon Authentication

Use the Authentication Settings menu to restrict management access based on specified user names and passwords. You can manually configure access rights on the switch, or you can use a remote access authentication server based on RADIUS or TACACS+ protocols.

Remote Authentication Dial-in User Service (RADIUS) and Terminal Access Controller Access Control System Plus (TACACS+) are logon authentication protocols that use software running on a central server to control access to RADIUS-aware or TACACS-aware devices on the network. An authentication server contains a database of multiple user name/password pairs with associated privilege levels for each user that requires management access to the switch.

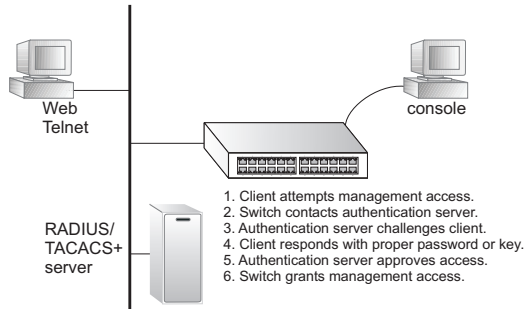

RADIUS uses UDP while TACACS+ uses TCP. UDP only offers best effort delivery, while TCP offers a connection-oriented transport. Also, note that RADIUS encrypts only the password in the access-request packet from the client to the server, while TACACS+ encrypts the entire body of the packet.

Command Usage

- By default, management access is always checked against the authentication database stored on the local switch. If a remote authentication server is used, you must specify the authentication sequence and the corresponding parameters for the remote authentication protocol. Local and remote logon authentication control management access via the console port, web browser, or Telnet.
- RADIUS and TACACS+ logon authentication assign a specific privilege level for each user name/password pair. The user name, password, and privilege level must be configured on the authentication server. The encryption methods used for the authentication process must also be configured or negotiated between the authentication server and logon client. This switch can pass authentication messages between the server and client that have been encrypted using MD5 (Message-Digest 5), TLS (Transport Layer Security), or TTLS (Tunneled Transport Layer Security).
- You can specify up to three authentication methods for any user to indicate the authentication sequence. For example, if you select (1) RADIUS, (2) TACACS and (3) Local, the user name and password on the RADIUS server is verified first. If the RADIUS server is not available, then authentication is attempted using the TACACS+ server, and finally the local user name and password is checked.

Command Attributes

- **Authentication** – Select the authentication, or authentication sequence required:
 - **Local** – User authentication is performed only locally by the switch.
 - **Radius** – User authentication is performed using a RADIUS server only.
 - **TACACS** – User authentication is performed using a TACACS+ server only.
 - [authentication sequence] – User authentication is performed by up to three authentication methods in the indicated sequence.
- **RADIUS Settings**
 - **Global** – Provides globally applicable RADIUS settings.
 - **ServerIndex** – Specifies one of five RADIUS servers that may be configured. The switch attempts authentication using the listed sequence of servers. The process ends when a server either approves or denies access to a user.
 - **Server IP Address**³ – Address of the RADIUS server. (Default: 10.1.0.1)
 - **Authentication Port Number** – Network (UDP) port of authentication server used for authentication messages. (Range: 1-65535; Default: 1812)
 - **Accounting Port Number** – UDP port on authentication server used for accounting messages. (Range: 1-65535; Default: 1813)
 - **Number of Server Transmits** – Number of times the switch tries to authenticate logon access via the authentication server. (Range: 1-30; Default: 2)
 - **Timeout for a reply** – The number of seconds the switch waits for a reply from the RADIUS server before it resends the request. (Range: 1-65535; Default: 5)
- **TACACS Settings**
 - **Global** – Provides globally applicable TACACS+ settings.
 - **ServerIndex** – Specifies the index number of the server to be configured. The switch currently supports only one TACACS+ server.
 - **Server IP Address**⁴ – Address of the TACACS+ server. (Default: 10.11.12.13)
 - **Server Port Number** – Network (TCP) port of TACACS+ server used for authentication messages. (Range: 1-65535; Default: 49)
 - **Number of Server Transmits** – Number of times the switch tries to authenticate logon access via the authentication server. (Range: 1-30; Default: 2)
 - **Timeout for a reply** – The number of seconds the switch waits for a reply from the RADIUS server before it resends the request. (Range: 1-540; Default: 5)

Note: The local switch user database has to be set up by manually entering user names and passwords using the Web or CLI. (See “Configuring User Accounts” on page 3-51 or “username” on page 4-37)

3. A Server Index must be selected to display this item.

4. A Server Index must be selected to display this item.

Web – Click Security, Authentication Settings. To configure local or remote authentication preferences, specify the authentication sequence (i.e., one to three methods), fill in the parameters for RADIUS or TACACS+ authentication if selected, and click Apply.

Authentication Settings

Authentication

RADIUS Settings:

<input checked="" type="radio"/> Global ServerIndex: <input type="radio"/> 1 <input type="radio"/> 2 <input type="radio"/> 3 <input type="radio"/> 4 <input type="radio"/> 5	
Authentication Port Number (1-65535)	<input type="text" value="1812"/>
Accounting Port Number (1-65535)	<input type="text" value="1813"/>
Number of Server Transmits (1-30)	<input type="text" value="2"/>
Timeout for a reply (1-65535)	<input type="text" value="5"/> (seconds)

TACACS Settings:

<input checked="" type="radio"/> Global ServerIndex: <input type="radio"/> 1	
Server Port Number (1-65535)	<input type="text" value="49"/>
Number of Server Transmits (1-30)	<input type="text" value="2"/>
Timeout for a reply (1-540)	<input type="text" value="5"/> (seconds)

Figure 3-34 Authentication Settings

3 Configuring the Switch

CLI – Specify all the required parameters to enable logon authentication.

```
Console(config)#authentication login radius 4-91
Console(config)#radius-server auth-port 181 4-95
Console(config)#radius-server key green 4-95
Console(config)#radius-server retransmit 5 4-96
Console(config)#radius-server timeout 10 4-96
Console(config)#radius-server 1 host 192.168.1.25 4-94
Console(config)#end
Console#show radius-server 4-96
```

```
Global Settings:
Communication Key with RADIUS Server:
Auth-Port: 181
Acct-port: 1813
Retransmit Times: 5
Request Timeout: 10
```

```
Server 1:
Server IP Address: 192.168.1.25
Communication Key with RADIUS Server: *****
Auth-Port: 181
Acct-port: 1813
Retransmit Times: 5
Request Timeout: 10
```

```
Radius server group:
Group Name Member Index
-----
radius 1
Console#
```

```
Console#configure
Console(config)#authentication login tacacs 4-91
Console(config)#tacacs-server 1 host 10.20.30.40 4-97
Console(config)#tacacs-server port 200 4-98
Console(config)#tacacs-server retransmit 5 4-99
Console(config)#tacacs-server timeout 10 4-99
Console(config)#tacacs-server key green 4-98
Console#show tacacs-server 4-100
```

Remote TACACS+ server configuration:

```
Global Settings:
Communication Key with TACACS+ Server:
Server Port Number: 200
Retransmit Times : 5
Request Times : 10
```

```
Server 1:
Server IP address: 10.20.30.40
Communication key with TACACS+ server: ****
Server port number: 200
Retransmit Times : 5
Request Times : 10
```

```
Tacacs server group:
Group Name Member Index
-----
tacacs+ 1
Console(config)#
```

Configuring Encryption Keys

The Encryption Key feature provides a central location for the management of all RADIUS and TACACS+ server encryption keys.

Command Attributes

• RADIUS Settings

- **Global** – Provides globally applicable RADIUS encryption key settings.
- **ServerIndex** – Specifies one of five RADIUS servers for which an encryption key may be configured.
- **Secret Text String** – Encryption key used to authenticate logon access for client. Do not use blank spaces in the string. (Maximum length: 20 (48?) characters)
- **Confirm Secret Text String** – Re-type the string entered in the previous field to ensure no errors were made. The switch will not change the encryption key if these two fields do not match.
- **Change** – Clicking this button adds or modifies the selected encryption key.

• TACACS+ Settings

- **Global** – Provides globally applicable TACACS+ encryption key settings.
- **ServerIndex** – Specifies the index number of the TACACS+ server for which an encryption key may be configured. The switch currently supports only one TACACS+ server.
- **Secret Text String** – Encryption key used to authenticate logon access for client. Do not use blank spaces in the string. (Maximum length: 20 (48?) characters)
- **Confirm Secret Text String** – Re-type the string entered in the previous field to ensure no errors were made. The switch will not change the encryption key if these two fields do not match.
- **Change** – Clicking this button adds or modifies the selected encryption key.

Web – Click Security, Encryption Key. Choose the appropriate RADIUS or TACACS+ ServerIndex, enter Secret Text String and confirm it, then click Change.

Encryption Key

RADIUS Settings:

<input type="radio"/> Global ServerIndex: <input type="radio"/> 1 <input type="radio"/> 2 <input type="radio"/> 3 <input type="radio"/> 4 <input type="radio"/> 5	
Secret Text String	<input type="text"/>
Confirm Secret Text String	<input type="text"/> <input type="button" value="Change"/>

TACACS Settings:

<input type="radio"/> Global ServerIndex: <input type="radio"/> 1	
Secret Text String	<input type="text"/>
Confirm Secret Text String	<input type="text"/> <input type="button" value="Change"/>

Figure 3-35 Encryption Key Settings

AAA Authorization and Accounting

The Authentication, authorization, and accounting (AAA) feature provides the main framework for configuring access control on the switch. The three security functions can be summarized as follows:

- Authentication — Identifies users that request access to the network.
- Authorization — Determines if users can access specific services.
- Accounting — Provides reports, auditing, and billing for services that users have accessed on the network.

The AAA functions require the use of configured RADIUS or TACACS+ servers in the network. The security servers can be defined as sequential groups that are then applied as a method for controlling user access to specified services. For example, when the switch attempts to authenticate a user, a request is sent to the first server in the defined group, if there is no response the second server will be tried, and so on. If at any point a pass or fail is returned, the process stops.

The switch supports the following AAA features:

- Accounting for IEEE 802.1X authenticated users that access the network through the switch.
- Accounting for users that access management interfaces on the switch through the console and Telnet.
- Accounting for commands that users enter at specific CLI privilege levels.
- Authorization of users that access management interfaces on the switch through the console and Telnet.

To configure AAA on the switch, you need to follow this general process:

1. Configure RADIUS and TACACS+ server access parameters. See “Configuring Local/Remote Logon Authentication” on page 3-53.
2. Define RADIUS and TACACS+ server groups to support the accounting and authorization of services.
3. Define a method name for each service to which you want to apply accounting or authorization and specify the RADIUS or TACACS+ server groups to use.
4. Apply the method names to port or line interfaces.

Note: This guide assumes that RADIUS and TACACS+ servers have already been configured to support AAA. The configuration of RADIUS and TACACS+ server software is beyond the scope of this guide, refer to the documentation provided with the RADIUS or TACACS+ server software.

Configuring AAA RADIUS Group Settings

The AAA RADIUS Group Settings screen defines the configured RADIUS servers to use for accounting and authorization.

Command Attributes

- **Group Name** - Defines a name for the RADIUS server group. (1-255 characters)
- **Server Index** - Specifies the RADIUS server and sequence to use for the group. (Range: 1-5)

When specifying the index for a RADIUS server, the server index must already be defined (see “Configuring Local/Remote Logon Authentication” on page 3-53).

Web – Click Security, AAA, Radius Group Settings. Enter the RADIUS group name, followed by the number of the server, then click Add.

AAA RADIUS Group Settings

Group Name	Server Index	Action
radius	1: 1 ▾ 2: 2 ▾ 3: 3 ▾ 4: 4 ▾ 5: 5 ▾	Remove
tps-radius	1: 5 ▾ 2: 4 ▾ 3: 2 ▾ 4: 1 ▾ 5: 3 ▾	Remove
<input style="width: 100%;" type="text"/>	1: ▾ 2: ▾ 3: ▾ 4: ▾ 5: ▾	Add

Figure 3-36 AAA Radius Group Settings

CLI – Specify the group name for a list of RADIUS servers, and then specify the index number of a RADIUS server to add it to the group.

```

Console(config)#aaa group server radius tps-radius           4-101
Console(config-sg-radius)#server 1                         4-102
Console(config-sg-radius)#server 2                         4-102
Console(config-sg-radius)#
  
```

Configuring AAA TACACS+ Group Settings

The AAA TACACS+ Group Settings screen defines the configured TACACS+ servers to use for accounting and authorization.

Command Attributes

- **Group Name** - Defines a name for the TACACS+ server group. (1-255 characters)
- **Server** - Specifies the TACACS+ server to use for the group. (Range: 1)

When specifying the index for a TACACS+ server, the server index must already be defined (see “Configuring Local/Remote Logon Authentication” on page 3-53).

3 Configuring the Switch

Web – Click Security, AAA, TACACS+ Group Settings. Enter the TACACS+ group name, followed by the number of the server, then click Add.

AAA TACACS+ Group Settings

Group Name	Server	Action
tacacs+	1	<input type="button" value="Remove"/>
tps-tacacs+	1	<input type="button" value="Remove"/>
<input type="text"/>	0	<input type="button" value="Add"/>

Figure 3-37 AAA TACACS+ Group Settings

CLI – Specify the group name for a list of TACACS+ servers, and then specify the index number of a TACACS+ server to add it to the group.

```
Console(config)#aaa group server tacacs+ tps-tacacs+          4-101
Console(config-sg-tacacs+)#server 1                          4-102
Console(config-sg-tacacs+)#
```

Configuring AAA Accounting

AAA accounting is a feature that enables the accounting of requested services for billing or security purposes.

Command Attributes

- **Method Name** – Specifies an accounting method for service requests.
The “default” methods are used for a requested service if no other methods have been defined. (Range: 1-255 characters)
The method name is only used to describe the accounting method(s) configured on the specified accounting servers, and do not actually send any information to the servers about the methods to use.
- **Service Request** – Specifies the service as either 802.1X (user accounting) or Exec (administrative accounting for local console, Telnet, or SSH connections).
- **Accounting Notice** – Records user activity from log-in to log-off point.
- **Group Name** - Specifies the accounting server group. (Range: 1-255 characters)
The group names “radius” and “tacacs+” specifies all configured RADIUS and TACACS+ hosts (see “Configuring Local/Remote Logon Authentication” on page 3-53). Any other group name refers to a server group configured on the RADIUS or TACACS+ Group Settings pages.

Web – Click Security, AAA, Accounting, Settings. To configure a new accounting method, specify a method name and a group name, then click Add.

AAA Accounting Settings

Method Name	Service Request	Accounting Notice	Group Name	Action
default	802.1X	start-stop ▾	radius	Remove
default	EXEC	start-stop ▾	tacacs+	Remove
default	Commands 0	start-stop ▾	tacacs+	Remove
default	Commands 1	start-stop ▾	tacacs+	Remove
default	Commands 2	start-stop ▾	tacacs+	Remove
default	Commands 3	start-stop ▾	tacacs+	Remove
default	Commands 4	start-stop ▾	tacacs+	Remove
default	Commands 5	start-stop ▾	tacacs+	Remove
default	Commands 6	start-stop ▾	tacacs+	Remove
default	Commands 7	start-stop ▾	tacacs+	Remove
default	Commands 8	start-stop ▾	tacacs+	Remove
default	Commands 9	start-stop ▾	tacacs+	Remove
default	Commands 10	start-stop ▾	tacacs+	Remove
default	Commands 11	start-stop ▾	tacacs+	Remove
default	Commands 12	start-stop ▾	tacacs+	Remove
default	Commands 13	start-stop ▾	tacacs+	Remove
default	Commands 14	start-stop ▾	tacacs+	Remove
default	Commands 15	start-stop ▾	tacacs+	Remove
tps-method	802.1X	start-stop ▾	tps-radius	Remove
<input type="text"/>	802.1X ▾ Privilege Level (0-15): <input type="text"/>	start-stop ▾	<input type="text"/>	Add

Figure 3-38 AAA Accounting Settings

CLI – Specify the accounting method required, followed by the chosen parameters.

```
Console(config)#aaa accounting dot1x tps start-stop group radius 4-102
Console(config)#
```

AAA Accounting Update

This feature sets the interval at which accounting updates are sent to accounting servers.

Command Attributes

Periodic Update - Specifies the interval at which the local accounting service updates information to the accounting server. (Range: 1-2147483647 minutes; Default: Disabled)

Web – Click Security, AAA, Accounting, Periodic Update. Enter the required update interval and click Apply.

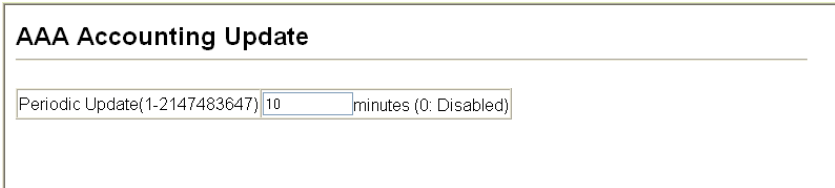

AAA Accounting Update

Periodic Update(1-2147483647) 10 minutes (0: Disabled)

Figure 3-39 AAA Accounting Update

CLI – This example sets the periodic accounting update interval at 10 minutes.

```
Console(config)#aaa accounting update periodic 10 4-105
Console(config)#
```

AAA Accounting 802.1X Port Settings

This feature applies the specified accounting method to an interface.

Command Attributes

- **Port/Trunk** - Specifies a port or trunk number.
- **Method Name** - Specifies a user defined method name to apply to the interface. This method must be defined in the AAA Accounting Settings menu (page 3-59). (Range: 1-255 characters)

Web – Click Security, AAA, Accounting, 802.1X Port Settings. Enter the required accounting method and click Apply.

AAA Accounting 802.1X Port Settings

Port	Method Name	Trunk
1	<input type="text" value="tps-method"/>	
2	<input type="text" value="tps-method"/>	
3	<input type="text" value="tps-method"/>	
4	<input type="text" value="tps-method"/>	
5	<input type="text" value="tps-method"/>	
6	<input type="text" value="tps-method"/>	
7	<input type="text" value="default"/>	
8	<input type="text" value="default"/>	
9	<input type="text" value="default"/>	
10	<input type="text" value="default"/>	

Figure 3-40 AAA Accounting 802.1X Port Settings

CLI – Specify the accounting method to apply to the selected interface.

```
Console (config)#interface ethernet 1/2
Console (config-if)#accounting dot1x tps-method
Console (config-if)#
```

4-106

AAA Accounting Exec Command Privileges

This feature specifies a method name to apply to commands entered at specific CLI privilege levels.

Command Attributes

- **Commands Privilege Level** - The CLI privilege levels (0-15).
- **Console/Telnet** - Specifies a user-defined method name to apply to commands entered at the specified CLI privilege level.

3 Configuring the Switch

Web – Click Security, AAA, Accounting, Command Privileges. Enter a defined method name for console and Telnet privilege levels. Click Apply.

Commands Privilege Level	Console	Telnet
0	default	default
1	default	default
2	default	default
3	default	default
4	default	default
5	default	default
6	default	default
7	default	default
8	default	default
9	default	default
10	default	default
11	default	default
12	default	default
13	default	default
14	default	default
15	tps-method	tps-method

Figure 3-41 AAA Accounting Exec Command Privileges

CLI – Specify the accounting method to use for console and Telnet privilege levels.

```
Console(config)#line console 4-12  
Console(config-line)#accounting commands 15 tps-method 4-107  
Console(config-line)#exit  
Console(config)#line vty  
Console(config-line)#accounting commands 15 tps-method  
Console(config-line)#
```

AAA Accounting Exec Settings

This feature specifies a method name to apply to console and Telnet connections.

Command Attributes

Method Name - Specifies a user defined method name to apply to console and Telnet connections.

Web – Click Security, AAA, Accounting, Exec Settings. Enter a defined method name for console and Telnet connections, and click Apply.

AAA Accounting Exec Settings

	Method Name
Console	<input type="text" value="tps-method"/>
Telnet	<input type="text" value="tps-method"/>

Figure 3-42 AAA Accounting Exec Settings

CLI – Specify the accounting method to use for Console and Telnet interfaces.

```

Console(config)#line console                               4-12
Console(config-line)#accounting exec tps-method           4-106
Console(config-line)#exit
Console(config)#line vty
Console(config-line)#accounting exec tps-method
Console(config-line)#
  
```

AAA Accounting Summary

This feature displays all accounting configured accounting methods, the methods applied to specified interfaces, and basic accounting information recorded for user sessions.

Command Attributes

AAA Accounting Summary

- **Accounting Type** - Displays the accounting service.
- **Method List** - Displays the user-defined or default accounting method.
- **Group List** - Displays the accounting server group.
- **Interface** - Displays the port or trunk to which these rules apply. (This field is null if the accounting method and associated server group has not been assigned to an interface.)

AAA Accounting Statistics Summary

- **User Name** - Displays a registered user name.
- **Interface** - Displays the receive port number through which this user accessed the switch.
- **Time Elapsed** - Displays the length of time this entry has been active.

3 Configuring the Switch

Web – Click Security, AAA, Summary.

AAA Accounting Summary

Accounting Type	Method List	Group List	Interface
802.1X	default	radius	
802.1X	tps-method	tps-radius	
EXEC	default	tacacs+	
Command 0	default	tacacs+	
Command 1	default	tacacs+	
Command 2	default	tacacs+	
Command 3	default	tacacs+	
Command 4	default	tacacs+	
Command 5	default	tacacs+	
Command 6	default	tacacs+	
Command 7	default	tacacs+	
Command 8	default	tacacs+	
Command 9	default	tacacs+	
Command 10	default	tacacs+	
Command 11	default	tacacs+	
Command 12	default	tacacs+	
Command 13	default	tacacs+	
Command 14	default	tacacs+	
Command 15	default	tacacs+	

AAA Accounting Statistics Summary
Total entries: 0

Accounting Type	User Name	Interface	Time Elapsed
-----------------	-----------	-----------	--------------

Figure 3-43 AAA Accounting Summary

CLI – Use the following command to display the currently applied accounting methods, and registered users.

```
Console#show accounting 4-109  
Accounting Type : dot1x  
  Method List   : default  
  Group List    : radius  
  Interface     :  
  
  Method List   : tps-method  
  Group List    : tps-radius  
  Interface     :  
  
Accounting Type : Exec  
  Method List   : default  
  Group List    : tacacs+  
  Interface     :  
  
Accounting Type : Commands 0  
  Method List   : default  
  Group List    : tacacs+  
  Interface     :
```

```

Console#show accounting statistics
Total entries: 3
Accounting type : dot1x
  Username      : testpc
  Interface     : eth 1/1
  Time elapsed  since connected: 00:24:44

Accounting type : exec
  Username      : admin
  Interface     : vty 0
  Time elapsed  since connected: 00:25:09

Console#

```

Authorization Settings

AAA authorization is a feature that verifies a user has access to specific services.

Command Attributes

- **Method Name** – Specifies an authorization method for service requests. The “default” method is used for a requested service if no other methods have been defined. (Range: 1-255 characters)
- **Service Request** – Specifies the service as Exec (authorization for local console or Telnet connections).
- **Group Name** - Specifies the authorization server group. (Range: 1-255 characters) The group name “tacacs+” specifies all configured TACACS+ hosts (see “Configuring Local/Remote Logon Authentication” on page 3-53). Any other group name refers to a server group configured on the TACACS+ Group Settings page. Authorization is only supported for TACACS+ servers.

Web – Click Security, AAA, Authorization, Settings. To configure a new authorization method, specify a method name and a group name, select the service, then click Add.

AAA Authorization Settings

Method Name	Service Request	Group Name	Action
default	Exec	tacacs+	Remove
auth-method	Exec	tps-tacacs+	Remove
<input type="text"/>	EXEC ▼	<input type="text"/>	Add

Figure 3-44 AAA Authorization Settings

CLI – Specify the authorization method required and the server group.

```

Console(config)#aaa authorization exec default group tacacs+
Console(config)#

```

4-107

Authorization EXEC Settings

This feature specifies an authorization method name to apply to console and Telnet connections.

Command Attributes

Method Name - Specifies a user-defined method name to apply to console and Telnet connections.

Web – Click Security, AAA, Authorization, Exec Settings. Enter a defined method name for console and Telnet connections, and click Apply.

AAA Authorization Exec Settings

	Method Name
Console	<input type="text" value="tps-auth"/>
Telnet	<input type="text" value="tps-auth"/>

Figure 3-45 AAA Authorization Exec Settings

CLI – Specify the authorization method to use for Console and Telnet interfaces.

```
Console(config)#line console 4-12  
Console(config-line)#authorization exec tps-auth 4-108  
Console(config-line)#exit  
Console(config)#line vty  
Console(config-line)#authorization exec tps-auth  
Console(config-line)#
```

Authorization Summary

The Authorization Summary displays the configured authorization methods and the interfaces to which they are applied.

Command Attributes

- **Authorization Type** - Displays the authorization service.
- **Method List** - Displays the user-defined or default authorization method.
- **Group List** - Displays the authorization server group.
- **Interface** - Displays the console or Telnet interface to which the authorization method applies. (This field is null if the authorization method and associated server group has not been assigned.)

Web – Click Security, AAA, Authorization, Summary.

AAA Authorization Summary			
Accounting Type	Method List	Group List	Interface
Exec	default	tacacs+	Console
Exec	auth-method	tps-tacacs+	

Figure 3-46 AAA Authorization Summary

Configuring HTTPS

You can configure the switch to enable the Secure Hypertext Transfer Protocol (HTTPS) over the Secure Socket Layer (SSL), providing secure access (i.e., an encrypted connection) to the switch's web interface.

Command Usage

- Both the HTTP and HTTPS service can be enabled independently on the switch. However, you cannot configure both services to use the same UDP port.
- If you enable HTTPS, you must indicate this in the URL that you specify in your browser: `https://device[:port_number]`
- When you start HTTPS, the connection is established in this way:
 - The client authenticates the server using the server's digital certificate.
 - The client and server negotiate a set of security protocols to use for the connection.
 - The client and server generate session keys for encrypting and decrypting data.
- The client and server establish a secure encrypted connection. A padlock icon should appear in the status bar for Internet Explorer 5.x or above and Netscape Navigator 6.2 or above.
- The following web browsers and operating systems currently support HTTPS:

Table 3-6 HTTPS System Support

Web Browser	Operating System
Internet Explorer 5.0 or later	Windows 98, Windows NT (with service pack 6a), Windows 2000, Windows XP
Netscape Navigator 6.2 or later	Windows 98, Windows NT (with service pack 6a), Windows 2000, Windows XP, Solaris 2.6

- To specify a secure-site certificate, see "Replacing the Default Secure-site Certificate" on page 3-70.

Command Attributes

- **HTTPS Status** – Allows you to enable/disable the HTTPS server feature on the switch. (Default: Enabled)

3 Configuring the Switch

- **Change HTTPS Port Number** – Specifies the UDP port number used for HTTPS connection to the switch's web interface. (Default: Port 443)

Web – Click Security, HTTPS Settings. Enable HTTPS and specify the port number, then click Apply.

HTTPS Settings	
HTTPS Status	<input checked="" type="checkbox"/> Enabled
Change HTTPS Port Number (1-65535)	443
Copy HTTPS Certificate	
TFTP Server IP Address	0.0.0.0
Source Certificate File Name	
Source Private File Name	
Private Password	
<input type="button" value="Copy Certificate"/>	

Figure 3-47 HTTPS Settings

CLI – This example enables the HTTP secure server and modifies the port number.

```
Console(config)#ip http secure-server 4-42
Console(config)#ip http secure-port 443 4-43
Console(config)#
```

Replacing the Default Secure-site Certificate

When you log onto the web interface using HTTPS (for secure access), a Secure Sockets Layer (SSL) certificate appears for the switch. By default, the certificate that Netscape and Internet Explorer display will be associated with a warning that the site is not recognized as a secure site. This is because the certificate has not been signed by an approved certification authority. If you want this warning to be replaced by a message confirming that the connection to the switch is secure, you must obtain a unique certificate and a private key and password from a recognized certification authority.

Caution: For maximum security, we recommend you obtain a unique Secure Sockets Layer certificate at the earliest opportunity. This is because the default certificate for the switch is not unique to the hardware you have purchased.

When you have obtained these, place them on your TFTP server and transfer them to the switch to replace the default (unrecognized) certificate with an authorized one.

Command Attributes

- **TFTP Server IP Address** – Specifies the IP address of the TFTP server which contains the certificate file.

- **Source Certificate File Name** – Specifies the name of certificate file as stored on the TFTP server.
- **Source Private File Name** – Specifies the name of the private key file as stored on the TFTP server.
- **Private Password** – The password for the private key file.

Web – Click Security, HTTPS Settings. Fill in the TFTP server, certificate and private file name details, then click Copy Certificate.

HTTPS Settings

HTTPS Status	<input checked="" type="checkbox"/> Enabled
Change HTTPS Port Number (1-65535)	443

Copy HTTPS Certificate

TFTP Server IP Address	0.0.0.0
Source Certificate File Name	
Source Private File Name	
Private Password	

Figure 3-48 HTTPS Settings

CLI – This example copies the certificate file from the designated TFTP server.

```

Console#copy tftp https-certificate                                     4-84
TFTP server ip address: <server ip-address>
Source certificate file name: <certificate file name>
Source private file name: <private key file name>
Private password: <password for private key>

```

Note: The switch must be reset for the new certificate to be activated. To reset the switch, See “Resetting the System” on page 3-33 or type: `Console#reload`

Configuring the Secure Shell

The Berkeley-standard includes remote access tools originally designed for Unix systems. Some of these tools have also been implemented for Microsoft Windows and other environments. These tools, including commands such as *rlogin* (remote login), *rsh* (remote shell), and *rcp* (remote copy), are not secure from hostile attacks.

The Secure Shell (SSH) includes server/client applications intended as a secure replacement for the older Berkeley remote access tools. SSH can also provide remote management access to this switch as a secure replacement for Telnet. When the client contacts the switch via the SSH protocol, the switch generates a public-key that the client uses along with a local user name and password for access authentication. SSH also encrypts all data transfers passing between the switch and

3 Configuring the Switch

SSH-enabled management station clients, and ensures that data traveling over the network arrives unaltered.

Note: You need to install an SSH client on the management station to access the switch for management via the SSH protocol.

Note: The switch supports both SSH Version 1.5 and 2.0 clients.

Command Usage

The SSH server on this switch supports both password and public key authentication. If password authentication is specified by the SSH client, then the password can be authenticated either locally or via a RADIUS or TACACS+ remote authentication server, as specified on the **Authentication Settings** page (page 3-53). If public key authentication is specified by the client, then you must configure authentication keys on both the client and the switch as described in the following section. Note that regardless of whether you use public key or password authentication, you still have to generate authentication keys on the switch (SSH Host Key Settings) and enable the SSH server (Authentication Settings).

To use the SSH server, complete these steps:

1. *Generate a Host Key Pair* – On the SSH Host Key Settings page, create a host public/private key pair.
2. *Provide Host Public Key to Clients* – Many SSH client programs automatically import the host public key during the initial connection setup with the switch. Otherwise, you need to manually create a known hosts file on the management station and place the host public key in it. An entry for a public key in the known hosts file would appear similar to the following example:

```
10.1.0.54 1024 35 15684995401867669259333946775054617325313674890836547254
15020245593199868544358361651999923329781766065830956 10825913212890233
76546801726272571413428762941301196195566782 59566410486957427888146206
51941746772984865468615717739390164779355942303577413098022737087794545
24083971752646358058176716709574804776117
```

3. *Import Client's Public Key to the Switch* – See "Importing User Public Keys" on page 3-77, or use the **copy ftp public-key** command (page 4-84) to copy a file containing the public key for all the SSH client's granted management access to the switch. (Note that these clients must be configured locally on the switch via the User Accounts page as described on page 3-51.) The clients are subsequently authenticated using these keys. The current firmware only accepts public key files based on standard UNIX format as shown in the following example for an RSA Version 1 key:

```
1024 35 1341081685609893921040944920155425347631641921872958921143173880
05553616163105177594083868631109291232226828519254374603100937187721199
69631781366277414168985132049117204830339254324101637997592371449011938
00609025394840848271781943722884025331159521348610229029789827213532671
31629432532818915045306393916643 steve@192.168.1.19
```

4. *Set the Optional Parameters* – On the SSH Settings page, configure the optional parameters, including the authentication timeout, the number of retries, and the server key size.
5. *Enable SSH Service* – On the SSH Settings page, enable the SSH server on the switch.
6. *Authentication* – One of the following authentication methods is employed:
Password Authentication (for SSH v1.5 or V2 Clients)
 - a. The client sends its password to the server.
 - b. The switch compares the client's password to those stored in memory.
 - c. If a match is found, the connection is allowed.

Note: To use SSH with only password authentication, the host public key must still be given to the client, either during initial connection or manually entered into the known host file. However, you do not need to configure the client's keys.

Public Key Authentication – When an SSH client attempts to contact the switch, the SSH server uses the host key pair to negotiate a session key and encryption method. Only clients that have a private key corresponding to the public keys stored on the switch can access it. The following exchanges take place during this process:

Authenticating SSH v1.5 Clients

- a. The client sends its RSA public key to the switch.
- b. The switch compares the client's public key to those stored in memory.
- c. If a match is found, the switch uses its secret key to generate a random 256-bit string as a challenge, encrypts this string with the user's public key, and sends it to the client.
- d. The client uses its private key to decrypt the challenge string, computes the MD5 checksum, and sends the checksum back to the switch.
- e. The switch compares the checksum sent from the client against that computed for the original string it sent. If the two checksums match, this means that the client's private key corresponds to an authorized public key, and the client is authenticated.

Authenticating SSH v2 Clients

- a. The client first queries the switch to determine if DSA public key authentication using a preferred algorithm is acceptable.
- b. If the specified algorithm is supported by the switch, it notifies the client to proceed with the authentication process. Otherwise, it rejects the request.
- c. The client sends a signature generated using the private key to the switch.
- d. When the server receives this message, it checks whether the supplied key is acceptable for authentication, and if so, it then checks whether the signature is correct. If both checks succeed, the client is authenticated.

Note: The SSH server supports up to four client sessions. The maximum number of client sessions includes both current Telnet sessions and SSH sessions.

3 Configuring the Switch

Configuring the SSH Server

The SSH server includes basic settings for authentication.

Field Attributes

- **SSH Server Status** – Allows you to enable/disable the SSH server on the switch. (Default: Disabled)
- **Version** – The Secure Shell version number. Version 2.0 is displayed, but the switch supports management access via either SSH Version 1.5 or 2.0 clients.
- **SSH Authentication Timeout** – Specifies the time interval in seconds that the SSH server waits for a response from a client during an authentication attempt. (Range: 1-120 seconds; Default: 120 seconds)
- **SSH Authentication Retries** – Specifies the number of authentication attempts that a client is allowed before authentication fails and the client has to restart the authentication process. (Range: 1-5 times; Default: 3)
- **SSH Server-Key Size** – Specifies the SSH server key size. (Range: 512-896 bits; Default:768)
 - The server key is a private key that is never shared outside the switch.
 - The host key is shared with the SSH client, and is fixed at 1024 bits.

Web – Click Security, SSH, Settings. Enable SSH and adjust the authentication parameters as required, then click Apply. Note that you must first generate the host key pair on the SSH Host-Key Settings page before you can enable the SSH server.

SSH Server Settings

SSH Server Status	<input type="checkbox"/> Enabled
Version	2.0
SSH Authentication Timeout (1-120)	<input type="text" value="120"/> seconds
SSH Authentication Retries (1-5)	<input type="text" value="3"/>
SSH Server-Key Size (512-896)	<input type="text" value="768"/>

Figure 3-49 SSH Server Settings

CLI – This example enables SSH, sets the authentication parameters, and displays the current configuration. It shows that the administrator has made a connection via SSH, and then disables this connection.

```

Console(config)#ip ssh server                                4-47
Console(config)#ip ssh timeout 100                          4-48
Console(config)#ip ssh authentication-retries 5             4-48
Console(config)#ip ssh server-key size 512                  4-49
Console(config)#end
Console#show ip ssh                                         4-51
SSH Enabled - version 2.0
Negotiation timeout: 120 secs; Authentication retries: 5
Server key size: 512 bits
Console#show ssh                                           4-52
Connection Version State      Username Encryption
 0           2.0   Session-Started      admin   ctos aes128-cbc-hmac-md5
                                         stoc aes128-cbc-hmac-md5
Console#disconnect 0                                         4-19
Console#

```

Generating the Host Key Pair

A host public/private key pair is used to provide secure communications between an SSH client and the switch. After generating this key pair, you must provide the host public key to SSH clients and import the client's public key to the switch as described in the section "Importing User Public Keys" on page 3-77.

Field Attributes

- **Public-Key of Host-Key** – The public key for the host.
 - RSA (Version 1): The first field indicates the size of the host key (e.g., 1024), the second field is the encoded public exponent (e.g., 65537), and the last string is the encoded modulus.
 - DSA (Version 2): The first field indicates that the encryption method used by SSH is based on the Digital Signature Standard (DSS). The last string is the encoded modulus.
- **Host-Key Type** – The key type used to generate the host key pair (i.e., public and private keys). (Range: RSA (Version 1), DSA (Version 2), Both; Default: RSA) The SSH server uses RSA or DSA for key exchange when the client first establishes a connection with the switch, and then negotiates with the client to select either DES (56-bit) or 3DES (168-bit) for data encryption.
- **Save Host-Key from Memory to Flash** – Saves the host key from RAM (i.e., volatile memory) to flash memory. Otherwise, the host key pair is stored to RAM by default. Note that you must select this item prior to generating the host-key pair.
- **Generate** – This button is used to generate the host key pair. Note that you must first generate the host key pair before you can enable the SSH server on the SSH Server Settings page.
- **Clear** – This button clears the host key from both volatile memory (RAM) and non-volatile memory (Flash).

3 Configuring the Switch

Web – Click Security, SSH, Host-Key Settings. Select the host-key type from the drop-down box, select the option to save the host key from memory to flash (if required) prior to generating the key, and then click Generate.

SSH Host-Key Settings

Public-Key of Host-Key

RSA

```
1024 65537
1309178972674789616152111712764979196296211551642422768028072510384048338276358290698941935742287566
1853076228099531413921379002210394737439417368512447371756369962704297907064627111321882467751081589
04315863193489542002094633406761281150405946811464259257326509438403478583707539552641213928004845007
811621891
```

DSA

```
ssh-dss
AAAA3NzaC1kc3MAAACBAJBVdKEITjKInEeBw3akiFa72nOPSPo8BdqFzeZeNk17DQ/N4hYx/W427x1AwJ1/dEO41o8fhOdcHZUb
kQXO08dq09/ IuvfHd+AEHxSnwzPZzLWUyMLDowHDGpKwWsmVcZkiJz1FrQs6XTaC1r30WbvoyP0c1id+Jj3Dc4tXq1AAAAFOCy
PELSe2E3S03Q+P32+SfpFA+cQAAAIAryRgej1/Zf8vVhC9M/YuIVfapHEDY18fcrpr1cSe8aIEE53gcHGuvQrvRLGH+zC1VVIdz
SVyYKHAUFqFntK0GCnhVQMjYmeEcGRqK7InWt20cXk4zR00tvyP5vCQaret3b1Ud1/=B2q7o3vnrukk0Xv1CbWFB80IjXJ50p
QwAAAIBBK3JwMn9MCT360x2H14sqQ7bu7Gv5GVuxH6zaY9Z2HP5ubvvI5SvWenuchCaRpfG0J1iVWVEmt cgeFzrAw5G3OY4iAR
qGQcN9iV1L4eVnxhRdx9O2H1WkJhW8HOPVH4Cw2FLHpFBnPL3MHqrvRYjNYBxJRaQV0ZK61kna6HQ==
```

Host-Key Type:

Save Host-Key from Memory to Flash

Figure 3-50 SSH Host-Key Settings

CLI – This example generates a host-key pair using both the RSA and DSA algorithms, stores the keys to flash memory, and then displays the host’s public keys.

```

Console#ip ssh crypto host-key generate                  4-47
Console#ip ssh save host-key                            4-47
Console#show public-key host                            4-47
Host:
RSA:
1024 65537 127250922544926402131336514546131189679055192360076028653006761
82409690947448320102524878965977592168322225584652387791546479807396314033
86925793105105765212243052807865885485789272602937866089236841423275912127
60325919683697053439336438445223335188287173896894511729290510813919642025
190932104328579045764891
DSA:
ssh-dss AAAA3NzaC1kc3MAAACBAN6zwIqCqDb3869jYVX1ME1sHL0EcE/Re6h1asfEthIwmj
hLY400jqZJpcEQUGCfYlum0Y2uoLka+Py9ieGWQ8f2gobUZKIICuK6vj09XTs7XKc05xfzkBi
KviDa+2OrIz6UK+6vFOgUVDFedlnixYTVo+h5v8r0ea2rpnO6DkZAAAAFPQCnZn/x17dwpW8RrV
DQnSWw4Qk+6QAAAI EAptkGeB6B5hwagH4gUOCY6i1TmrmSiJgfw090qRPUMbCAkCC+uzxatOo7
drnLZypMx+Sx5RUDMGgKS+9ywsalCWgHeFY51lc3lDCNBueeLykZzV5+RS+azTKIk/rrJh8GLG
Nq375R55yRxFvmcGIn/Q7IphPqyJ3o9MK8LFDfmJEAAACAL8A6tESiSwP2OFqX7VG0EbzwVDSOI
RTMfY3iUxtvGyQAOVSY67Mfc31MtggPRUOYXDiwIBp5NXg1Cg5z7VqbmRm28mWc5a//f8TUAq
PNWkV6W0hqmqShdotVzDR1e+XKNTZj0uTWwfj05Kyt4n4MdoTHgrbl/DMAfjnte8MZZs=
Console#

```

Importing User Public Keys

A user's Public Key must be uploaded to the switch in order for the user to be able to log in using the public key authentication mechanism. If the user's public key does not exist on the switch, SSH will revert to the interactive password authentication mechanism to complete authentication.

Field Attributes

- **Public-Key of user** – The RSA and DSA public keys for the selected user.
 - RSA: The first field indicates the size of the host key (e.g., 1024), the second field is the encoded public exponent (e.g., 37), and the last string is the encoded modulus.
 - DSA: The first field indicates that SSH version 2 was used to create the key. The second field contains the key comment. The third string is the encoded modulus, and the last field is a comment denoting the end of the key.
- **User Name** – This drop-down box selects the user who's public key you wish to manage. Note that you must first create users on the User Accounts page (See "Configuring User Accounts" on page 3-51).
- **Public-Key Type** – This drop-down box selects the type of public key you wish to upload.
 - RSA: The switch will accept an SSH version 1 formatted RSA encrypted public key.
 - DSA: The switch will accept an SSH version 2 formatted DSA encrypted public key.
- **TFTP Server IP Address** – The IP address of the TFTP server that contains the public key file you wish to import. (Default: 0.0.0.0)
- **Source File Name** – The IP address of the TFTP server where the public key file to be imported is located. (Default: 0.0.0.0)
- **Copy Public Key** – This button initiates the public key TFTP import process. If you are replacing an outdated public key file, it is not necessary to first delete the original key from the switch. The import process will overwrite the existing key.
- **Delete** – This button deletes a selected RSA or DSA public key that has already been imported to the switch.

3 Configuring the Switch

Web – Click Security, SSH, SSH User Public-Key Settings. Select the user name and the public-key type from the respective drop-down boxes, input the TFTP server IP address and the public key source file name, and then click Copy Public Key.

SSH User Public-Key Settings

Public-Key of admin	
RSA	1024 37 154886675541099600242673908076171863880953984597454546825066951007296174327427136900505591624068119579408716226078634780682201498685790475062345194806799394850426535041791530327953374221033566950264419038234458357308882347288969084262166542903131593765281527938786829853982046614347413002309979848162607182657 rsa-key-20071106
DSA	----- BEGIN SSH2 PUBLIC KEY ----- Comment: "dsa-key-20071105" AAAAB3NzaC1kc3MAAACAgNnwpAVz82Z3zFif0KGF846S5m5useW8rQp8DBv1IQ/ sLYRuoCtW/+hllaUu2F9Ps6D5gJdKjyEPKRutJv1rAwq1YZ61/fat9OGpM3oaqM f6UiVUK4gEsaq8T6UqrGslDcXWYymbI02+R/owN43kwEJCfmpBXelhU962AA2G0A AAAVAkxtZo+MjTzrJ+9mFTfUpawm7HAAAAgCINbco4jTWcdMKS1oQTA+WnCeht sd8j5MpDc3VccySMaFzcPgxT+N79WVxWnJQaS8i9TY3EDg9VfCooLZDrmYX67M V3pIJeJ57DsNjLnCHpaGE/OKfkAhvjRzIufS4f4wAzOYCBNxb6XY6Vew8Pi7Wri L/Xrm4AQ0t4wSjEAAAAGDNcKKEpZw16wW7E9EmbQp5s5gu9lCVcQmZ5r76EyEzc 9ulYvxy54GHMtyBwLTTtH6lxbEGD6cOnkCW+ieRye9fiJfs7u4QdL9NZb+WLVzvcU Xm6E1vUc70OpelDFxbfhQawgGFxx7Ryzb85D75ffNEqLW2mKAp ehUqRHYbPZOx ----- END SSH2 PUBLIC KEY -----

User Name	admin
Public-Key Type	RSA
TFTP Server IP Address	0.0.0.0
Source File Name	

Figure 3-51 SSH User Public-Key Settings

CLI – This example imports an SSHv2 DSA public key for the user admin and then displays admin's imported public keys.

```

Console#copy tftp public-key                                4-84
TFTP server IP address: 192.168.1.254
Choose public key type:
 1. RSA:  2. DSA: <1-2>: 2
Source file name: admin-ssh2-dsa-pub.key
Username: admin
TFTP Download
Success.
Write to FLASH Programming.
Success.

Console#show public-key user admin                        4-53
admin:
RSA:
1024 37 154886675541099600242673908076171863880953984597454546825066951007
29617437427136900505591624068119579408716226078634780682201498685790475062
34519480679939485042653504179153032795337422103356695026441903823445835730
88823472889690842821665429031315937652815279387868298539820466143474130023
09979848162607182657  rsa-key-20071106

DSA:
---- BEGIN SSH2 PUBLIC KEY ----
Comment: "dsa-key-20071105"
AAAAB3NzaC1kc3MAAA
CAeqNnwpAVz82Z3zFif0KGF846S5m5useW8rQp8DBv1IQ/
sLYRuoCtW/+h11IaUu2F9Ps6D5gJdKj
yEPKRutJv1rAwq1YZ61/fat9OGpM3oaqM
f6UiVUK4gEsaq8T6UqrGsIDcXWYvmbI02+R/owN43kwe
JCfmpBXelhU962AA2G0A
AAAVAKxtZo+MjTVzRJ+9mFTFIUpawm7HAAAAGCINbco4jTWcdMKS1oQTA
+WnCehl
sd8j5MpDc3VccySMaFzcPgxT+N79VWxWNJQaS819TFy3EDG9VfCoOLZDrn/yX67M
V3p/I
Jej57DsNjLnCHpaGE/OKfkAhvjRz1ufS4f4wAzOYCBNxb6XY6Vew8Pi7Wri
L/Xrm4AQ0t4wSjjEAA
AAgDNcKKEpZw16wW7E9EmbQp5s5gu9lCVCqMz5r76EyEzc
9uIYvxy54GHMtyBwLTTTh61bxEGD6cO
nkCW+ieRye9fiJfs7u4QdL9N2b+WLVzcU
Xm6ElvUc70OpelDFxbfhQawgGFvxv7rzv85D75ffNEqB
LW2mKApehuQrHYbPZOnX
---- END SSH2 PUBLIC KEY ----

Console#

```

Configuring Port Security

Port security is a feature that allows you to configure a switch port with one or more device MAC addresses that are authorized to access the network through that port.

When port security is enabled on a port, the switch stops learning new MAC addresses on the specified port when it has reached a configured maximum number. Only incoming traffic with source addresses already stored in the dynamic or static address table will be accepted as authorized to access the network through that port. If a device with an unauthorized MAC address attempts to use the switch port, the intrusion will be detected and the switch can automatically take action by disabling the port and sending a trap message.

To use port security, specify a maximum number of addresses to allow on the port and then let the switch dynamically learn the <source MAC address, VLAN> pair for frames received on the port. Note that you can also manually add secure addresses to the port using the Static Address Table (page 3-133). When the port has reached the maximum number of MAC addresses the selected port will stop learning. The MAC addresses already in the address table will be retained and will not age out. Any other device that attempts to use the port will be prevented from accessing the switch.

Command Usage

- A secure port has the following restrictions:
 - It cannot use port monitoring.
 - It cannot be a multi-VLAN port.
 - It cannot be used as a member of a static or dynamic trunk.
 - It should not be connected to a network interconnection device.
- The default maximum number of MAC addresses allowed on a secure port is zero. You must configure a maximum address count from 1 - 1024 for the port to allow access.
- If a port is disabled (shut down) due to a security violation, it must be manually re-enabled from the Port/Port Configuration page (page 3-112).

Command Attributes

- **Port** – Port number.
- **Name** – Descriptive text (page 4-167).
- **Action** – Indicates the action to be taken when a port security violation is detected:
 - **None**: No action should be taken. (This is the default.)
 - **Trap**: Send an SNMP trap message.
 - **Shutdown**: Disable the port.
 - **Trap and Shutdown**: Send an SNMP trap message and disable the port.
- **Security Status** – Enables or disables port security on the port. (Default: Disabled)
- **Max MAC Count** – The maximum number of MAC addresses that can be learned on a port. (Range: 0 - 1024, where 0 means disabled)
- **Trunk** – Trunk number if port is a member (page 3-115 and 3-116).

Web – Click Security, Port Security. Set the action to take when an invalid address is detected on a port, mark the checkbox in the Status column to enable security for a port, set the maximum number of MAC addresses allowed on a port, and click Apply.

Configuration:

Port	Name	Action	Security Status	Max MAC Count (0-1024)	Trunk
1		None	<input type="checkbox"/> Enabled	0	
2		None	<input type="checkbox"/> Enabled	0	
3		None	<input type="checkbox"/> Enabled	0	
4		None	<input type="checkbox"/> Enabled	0	
5		Trap and Shutdown	<input checked="" type="checkbox"/> Enabled	20	
6		None	<input type="checkbox"/> Enabled	0	

Figure 3-52 Configuring Port Security

CLI – This example selects the target port, sets the port security action to send a trap and disable the port and sets the maximum MAC addresses allowed on the port, and then enables port security for the port.

```

Console(config)#interface ethernet 1/5
Console(config-if)#port security action trap-and-shutdown           4-110
Console(config-if)#port security max-mac-count 20                 4-110
Console(config-if)#port security                                  4-110
Console(config-if)#

```

Configuring 802.1X Port Authentication

Network switches can provide open and easy access to network resources by simply attaching a client PC. Although this automatic configuration and access is a desirable feature, it also allows unauthorized personnel to easily intrude and possibly gain access to sensitive network data.

The IEEE 802.1X (dot1X) standard defines a port-based access control procedure that prevents unauthorized access to a network by requiring users to first submit credentials for authentication. Access to all switch ports in a network can be centrally controlled from a server, which means that authorized users can use the same credentials for authentication from any point within the network.

3 Configuring the Switch

This switch uses the Extensible Authentication Protocol over LANs (EAPOL) to exchange authentication protocol messages with the client, and a remote RADIUS authentication server to verify user identity and access rights. When a client (i.e., Supplicant) connects to a switch port, the switch (i.e.,

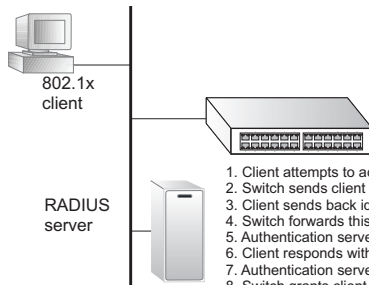

1. Client attempts to access a switch port.
2. Switch sends client an identity request.
3. Client sends back identity information.
4. Switch forwards this to authentication server.
5. Authentication server challenges client.
6. Client responds with proper credentials.
7. Authentication server approves access.
8. Switch grants client access to this port.

Authenticator) responds with an EAPOL identity request. The client provides its identity (such as a user name) in an EAPOL response to the switch, which it forwards to the RADIUS server. The RADIUS server verifies the client identity and sends an access challenge back to the client. The EAP packet from the RADIUS server contains not only the challenge, but the authentication method to be used. The client can reject the authentication method and request another, depending on the configuration of the client software and the RADIUS server. The encryption method used to pass authentication messages can be MD5 (Message-Digest 5), TLS (Transport Layer Security), PEAP (Protected Extensible Authentication Protocol), or TTLS (Tunneled Transport Layer Security). The client responds to the appropriate method with its credentials, such as a password or certificate. The RADIUS server verifies the client credentials and responds with an accept or reject packet. If authentication is successful, the switch allows the client to access the network. Otherwise, non-EAP traffic on the port is blocked or assigned to a guest VLAN based on the “intrusion-action” setting. In “multi-host” mode, only one host connected to a port needs to pass authentication for all other hosts to be granted network access. Similarly, a port can become unauthorized for all hosts if one attached host fails re-authentication or sends an EAPOL logoff message.

The operation of 802.1X on the switch requires the following:

- The switch must have an IP address assigned.
- RADIUS authentication must be enabled on the switch and the IP address of the RADIUS server specified.
- 802.1X must be enabled globally for the switch.
- Each switch port that will be used must be set to dot1X “Auto” mode.
- Each client that needs to be authenticated must have dot1X client software installed and properly configured.
- The RADIUS server and 802.1X client support EAP. (The switch only supports EAPOL in order to pass the EAP packets from the server to the client.)
- The RADIUS server and client also have to support the same EAP authentication type – MD5, PEAP, TLS, or TTLS. (Some clients have native support in the operating system, otherwise the dot1x client must support the required authentication method.)

Displaying 802.1X Global Settings

The 802.1X protocol provides client authentication.

Command Attributes

- **802.1X System Authentication Control** – The global setting for 802.1X.

Web – Click Security, 802.1X, Information.



Figure 3-53 802.1X Global Information

CLI – This example shows the default global setting for 802.1X.

```

Console#show dot1x                                     4-117
Global 802.1X Parameters
  system-auth-control: enable

802.1X Port Summary

Port Name   Status      Operation Mode   Mode              Authorized
1/1         disabled   Single-Host      ForceAuthorized   n/a
1/2         disabled   Single-Host      ForceAuthorized   n/a
.
.
802.1X Port Details

802.1X is disabled on port 1/1
.
.
802.1X is disabled on port 1/28
Console#

```

Configuring 802.1X Global Settings

The 802.1X protocol provides port authentication. The 802.1X protocol must be enabled globally for the switch system before port settings are active.

Command Attributes

- **802.1X System Authentication Control** – Sets the global setting for 802.1X. (Default: Disabled)

3 Configuring the Switch

Web – Select Security, 802.1X, Configuration. Enable 802.1X globally for the switch, and click Apply.

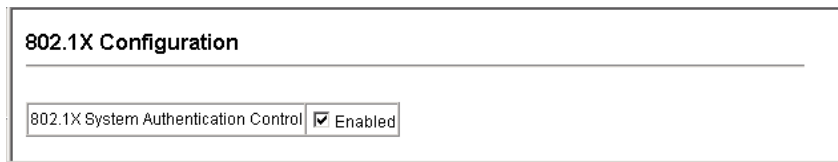

802.1X Configuration

802.1X System Authentication Control Enabled

Figure 3-54 802.1X Global Configuration

CLI – This example enables 802.1X globally for the switch.

```
Console(config)#dot1x system-auth-control 4-112
Console(config)#
```

Configuring Port Settings for 802.1X

When 802.1X is enabled, you need to configure the parameters for the authentication process that runs between the client and the switch (i.e., authenticator), as well as the client identity lookup process that runs between the switch and authentication server. These parameters are described in this section.

Command Attributes

- **Port** – Port number.
- **Status** – Indicates if authentication is enabled or disabled on the port. (Default: Disabled)
- **Operation Mode** – Allows single or multiple hosts (clients) to connect to an 802.1X-authorized port. (Options: Single-Host, Multi-Host; Default: Single-Host)
- **Max Count** – The maximum number of hosts that can connect to a port when the Multi-Host operation mode is selected. (Range: 1-1024; Default: 5)
- **Mode** – Sets the authentication mode to one of the following options:
 - **Auto** – Requires a dot1x-aware client to be authorized by the authentication server. Clients that are not dot1x-aware will be denied access.
 - **Force-Authorized** – Forces the port to grant access to all clients, either dot1x-aware or otherwise. (This is the default setting.)
 - **Force-Unauthorized** – Forces the port to deny access to all clients, either dot1x-aware or otherwise.
- **Re-authentication** – Sets the client to be re-authenticated after the interval specified by the Re-authentication Period. Re-authentication can be used to detect if a new device is plugged into a switch port. (Default: Disabled)
- **Max-Request** – Sets the maximum number of times the switch port will retransmit an EAP request packet to the client before it times out the authentication session. (Range: 1-10; Default 2)
- **Quiet Period** – Sets the time that a switch port waits after the Max Request Count has been exceeded before attempting to acquire a new client. (Range: 1-65535 seconds; Default: 60 seconds)

- **Re-authentication Period** – Sets the time period after which a connected client must be re-authenticated. (Range: 1-65535 seconds; Default: 3600 seconds)
- **Tx Period** – Sets the time period during an authentication session that the switch waits before re-transmitting an EAP packet. (Range: 1-65535; Default: 30 seconds)
- **Intrusion Action** – Sets the port's response to a failed authentication.
 - Block Traffic – Blocks all non-EAP traffic on the port. (This is the default setting.)
 - Guest VLAN – All traffic for the port is assigned to a guest VLAN. The guest VLAN must be separately configured (See “Creating VLANs” on page 3-163) and mapped on each port (See “Configuring MAC Authentication for Ports” on page 3-94).
- **Authorized** – Displays the 802.1X authorization status of connected clients.
 - **Yes** – Connected client is authorized.
 - **No** – Connected client is not authorized.
 - *Blank* – Displays nothing when dot1x is disabled on a port.
- **Supplicant** – Indicates the MAC address of a connected client.
- **Trunk** – Indicates if the port is configured as a trunk port.

Web – Click Security, 802.1X, Port Configuration. Modify the parameters required, and click Apply.

802.1X Port Configuration													
Port	Status	Operation Mode	Max Count (1-1024)	Mode	Re-authen	Max-Req	Quiet/Period	Re-authen/Period	Tx Period	Intrusion Action	Authorized	Supplicant	Trunk
1	Disabled	Single-Host	5	Force-Unauthorized	<input type="checkbox"/> Enable	2	60	3600	30	Block Traffic	Yes	00:00:00-00:00:00	
2	Enabled	Single-Host	5	Auto	<input checked="" type="checkbox"/> Enable	2	60	3600	30	Guest VLAN		00:00:00-00:00:00	
3	Disabled	Single-Host	5	Force-Unauthorized	<input type="checkbox"/> Enable	2	60	3600	30	Block Traffic		00:00:00-00:00:00	
4	Disabled	Single-Host	5	Force-Unauthorized	<input type="checkbox"/> Enable	2	60	3600	30	Block Traffic		00:00:00-00:00:00	
5	Disabled	Single-Host	5	Force-Unauthorized	<input type="checkbox"/> Enable	2	60	3600	30	Block Traffic		00:00:00-00:00:00	
6	Disabled	Single-Host	5	Force-Unauthorized	<input type="checkbox"/> Enable	2	60	3600	30	Block Traffic		00:00:00-00:00:00	
7	Disabled	Single-Host	5	Force-Unauthorized	<input type="checkbox"/> Enable	2	60	3600	30	Block Traffic		00:00:00-00:00:00	
8	Disabled	Single-Host	5	Force-Unauthorized	<input type="checkbox"/> Enable	2	60	3600	30	Block Traffic		00:00:00-00:00:00	
9	Disabled	Single-Host	5	Force-Unauthorized	<input type="checkbox"/> Enable	2	60	3600	30	Block Traffic		00:00:00-00:00:00	
10	Disabled	Single-Host	5	Force-Unauthorized	<input type="checkbox"/> Enable	2	60	3600	30	Block Traffic		00:00:00-00:00:00	
11	Disabled	Single-Host	5	Force-Unauthorized	<input type="checkbox"/> Enable	2	60	3600	30	Block Traffic		00:00:00-00:00:00	
12	Disabled	Single-Host	5	Force-Unauthorized	<input type="checkbox"/> Enable	2	60	3600	30	Block Traffic		00:00:00-00:00:00	
13	Disabled	Single-Host	5	Force-Unauthorized	<input type="checkbox"/> Enable	2	60	3600	30	Block Traffic		00:00:00-00:00:00	
14	Disabled	Single-Host	5	Force-Unauthorized	<input type="checkbox"/> Enable	2	60	3600	30	Block Traffic		00:00:00-00:00:00	
15	Disabled	Single-Host	5	Force-Unauthorized	<input type="checkbox"/> Enable	2	60	3600	30	Block Traffic		00:00:00-00:00:00	
16	Disabled	Single-Host	5	Force-Unauthorized	<input type="checkbox"/> Enable	2	60	3600	30	Block Traffic		00:00:00-00:00:00	
17	Disabled	Single-Host	5	Force-Unauthorized	<input type="checkbox"/> Enable	2	60	3600	30	Block Traffic		00:00:00-00:00:00	
18	Disabled	Single-Host	5	Force-Unauthorized	<input type="checkbox"/> Enable	2	60	3600	30	Block Traffic		00:00:00-00:00:00	
19	Disabled	Single-Host	5	Force-Unauthorized	<input type="checkbox"/> Enable	2	60	3600	30	Block Traffic		00:00:00-00:00:00	
20	Disabled	Single-Host	5	Force-Unauthorized	<input type="checkbox"/> Enable	2	60	3600	30	Block Traffic		00:00:00-00:00:00	
21	Disabled	Single-Host	5	Force-Unauthorized	<input type="checkbox"/> Enable	2	60	3600	30	Block Traffic		00:00:00-00:00:00	
22	Disabled	Single-Host	5	Force-Unauthorized	<input type="checkbox"/> Enable	2	60	3600	30	Block Traffic		00:00:00-00:00:00	

Figure 3-55 802.1X Port Configuration

3 Configuring the Switch

CLI – This example sets the 802.1X parameters on port 2. For a description of the additional fields displayed in this example, see “show dot1x” on page 4-117.

```
Console(config)#interface ethernet 1/2 4-166
Console(config-if)#dot1x port-control auto 4-113
Console(config-if)#dot1x re-authentication 4-115
Console(config-if)#dot1x max-req 5 4-113
Console(config-if)#dot1x timeout quiet-period 30 4-115
Console(config-if)#dot1x timeout re-authperiod 1800 4-116
Console(config-if)#dot1x timeout tx-period 40 4-116
Console(config-if)#dot1x intrusion-action guest-vlan 4-117
Console(config-if)#exit
Console(config)#exit
Console#show dot1x 4-117
Global 802.1X Parameters
  system-auth-control: enable

802.1X Port Summary

Port Name   Status           Operation Mode   Mode              Authorized
-----
1/1         disabled        Single-Host     ForceAuthorized   n/a
1/2         enabled         Single-Host     auto              yes
.
.
1/28        disabled        Single-Host     ForceAuthorized   n/a

802.1X Port Details

802.1X is disabled on port 1/1

802.1X is enabled on port 1/2
reauth-enabled: Enable
reauth-period: 1800
quiet-period: 30
tx-period: 40
supplicant-timeout: 30
server-timeout: 10
reauth-max: 2
max-req: 5

Status           Authorized
Operation mode   Single-Host
Max count        5
Port-control     Auto
Supplicant       00-12-CF-49-5e-dc
Current Identifier 3
Intrusion action Guest VLAN

Authenticator State Machine
State            Authenticated
Reauth Count     0

Backend State Machine
State            Idle
Request Count    0
Identifier(Server) 2

Reauthentication State Machine
State            Initialize
.
.
802.1X is disabled on port 1/28
Console#
```

Displaying 802.1X Statistics

This switch can display statistics for dot1x protocol exchanges for any port.

Table 3-7 802.1X Statistics

Parameter	Description
Rx EAPOL Start	The number of EAPOL Start frames that have been received by this Authenticator.
Rx EAPOL Logoff	The number of EAPOL Logoff frames that have been received by this Authenticator.
Rx EAPOL Invalid	The number of EAPOL frames that have been received by this Authenticator in which the frame type is not recognized.
Rx EAPOL Total	The number of valid EAPOL frames of any type that have been received by this Authenticator.
Rx EAP Resp/ld	The number of EAP Resp/ld frames that have been received by this Authenticator.
Rx EAP Resp/Oth	The number of valid EAP Response frames (other than Resp/ld frames) that have been received by this Authenticator.
Rx EAP LenError	The number of EAPOL frames that have been received by this Authenticator in which the Packet Body Length field is invalid.
Rx Last EAPOLVer	The protocol version number carried in the most recently received EAPOL frame.
Rx Last EAPOLSrc	The source MAC address carried in the most recently received EAPOL frame.
Tx EAPOL Total	The number of EAPOL frames of any type that have been transmitted by this Authenticator.
Tx EAP Req/ld	The number of EAP Req/ld frames that have been transmitted by this Authenticator.
Tx EAP Req/Oth	The number of EAP Request frames (other than Rq/ld frames) that have been transmitted by this Authenticator.

3 Configuring the Switch

Web – Select Security, 802.1X, Statistics. Select the required port and then click Query. Click Refresh to update the statistics.

802.1X Statistics

Port: 4

Query

Rx EAPOL Start	0	Rx EAP LenError	0
Rx EAPOL Logoff	0	Rx Last EAPOLVer	0
Rx EAPOL Invalid	0	Rx Last EAPOLSrc	00-00-00-00-00-00
Rx EAPOL Total	0	Tx EAPOL Total	0
Rx EAP Resp/Id	0	Tx EAP Req/Id	0
Rx EAP Resp/Oth	0	Tx EAP Req/Oth	0

Refresh

Figure 3-56 Displaying 802.1X Port Statistics

CLI – This example displays the 802.1X statistics for port 4.

```
Console#show dot1x statistics interface ethernet 1/4 4-117

Eth 1/4
Rx: EAPOL      EAPOL      EAPOL      EAPOL      EAP      EAP      EAP
   Start      Logoff      Invalid      Total      Resp/Id  Resp/Oth LenError
       2         0         0         1007      672      0         0

   Last      Last
EAPOLVer    EAPOLSrc
   1         00-12-CF-94-34-DE

Tx: EAPOL      EAP      EAP
   Total      Req/Id  Req/Oth
   2017      1005   0
Console#
```

Web Authentication

Web authentication allows stations to authenticate and access the network in situations where 802.1X or Network Access authentication are infeasible or impractical. The web authentication feature allows unauthenticated hosts to request and receive a DHCP assigned IP address and perform DNS queries. All other traffic, except for HTTP protocol traffic, is blocked. The switch intercepts HTTP protocol traffic and redirects it to a switch-generated web page that facilitates username and password authentication via RADIUS. Once authentication is successful, the web browser is forwarded on to the originally requested web page. Successful authentication is valid for all hosts connected to the port.

- Notes:**
1. MAC authentication, web authentication, 802.1X, and port security cannot be configured together on the same port. Only one security mechanism can be applied.
 2. RADIUS authentication must be activated and configured properly for the web authentication feature to work properly. (See "Configuring Local/Remote Logon Authentication" on page 3-53)
 3. Web authentication cannot be configured on trunk ports.

Configuring Web Authentication

Web authentication is configured on a per-port basis, however there are four configurable parameters that apply globally to all ports on the switch.

Command Attributes

- **System Authentication Control** – Enables Web Authentication for the switch. (Default: Disabled)
- **Session Timeout** – Configures how long an authenticated session stays active before it must re-authenticate itself. (Default: 3600 seconds; Range: 300-3600 seconds)
- **Quiet Period** – Configures how long a host must wait to attempt authentication again after it has exceeded the maximum allowable failed login attempts. (Default: 60 seconds; Range: 1-180 seconds)
- **Login Attempts** – Configures the amount of times a supplicant may attempt and fail authentication before it must wait the configured quiet period. (Default: 3 attempts; Range: 1-3 attempts)

Web – Click Security, Web Authentication, Configuration.

Web Authentication Configuration	
System Authentication Control	<input type="checkbox"/> Enabled
Session Timeout(300-3600)	3600 seconds
Quiet Period(1-180)	60 seconds
Login Attempts(1-3)	3

Figure 3-57 Web Authentication Configuration

3 Configuring the Switch

CLI – This example globally enables the system authentication control, configures the session timeout, quiet period and login attempts, and displays the configured global parameters.

```
Console(config)#mac-authentication reauth-time 3000 4-126
Console(config)#web-auth system-auth-control 4-133
Console(config)#web-auth session-timeout 1800 4-132
Console(config)#web-auth quiet-period 20 4-132
Console(config)#web-auth login-attempts 2 4-130
Console(config)#end
Console#show web-auth 4-134

Global Web-Auth Parameters

System Auth Control      : Enabled
Login Page URL           :
Login Fail Page URL      :
Login Success Page URL   :
Session Timeout          : 1800
Quiet Period              : 20
Max Login Attempts       : 2
Console#
```

Configuring Web Authentication for Ports

Web authentication is configured on a per-port basis. The following parameters are associated with each port.

Command Attributes

- **Port** – Indicates the port being configured
- **Status** – Configures the web authentication status for the port.
- **Authenticated Host Counts** – Indicates how many authenticated hosts are connected to the port.

Web – Click Security, Web Authentication, Port Configuration.

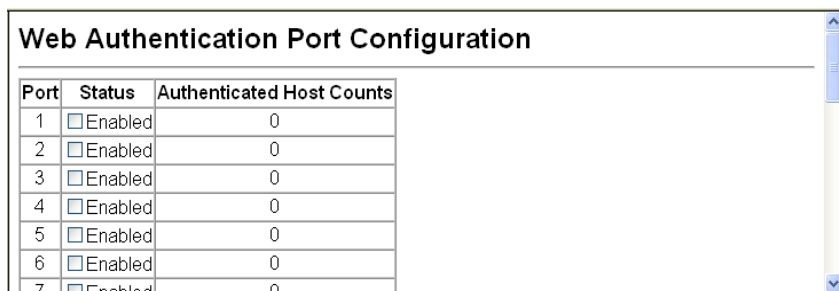

Port	Status	Authenticated Host Counts
1	<input checked="" type="checkbox"/> Enabled	0
2	<input checked="" type="checkbox"/> Enabled	0
3	<input checked="" type="checkbox"/> Enabled	0
4	<input checked="" type="checkbox"/> Enabled	0
5	<input checked="" type="checkbox"/> Enabled	0
6	<input checked="" type="checkbox"/> Enabled	0
7	<input checked="" type="checkbox"/> Enabled	0

Figure 3-58 Web Authentication Port Configuration

CLI – This example enables web authentication for ethernet port 1/5 and displays a summary of web authentication parameters.

```

Console(config)#interface ethernet 1/5          4-166
Console(config-if)#web-auth                    4-133
Console(config-if)#end
Console#show web-auth summary                  4-136

Global Web-Auth Parameters

  System Auth Control      : Enabled
Port      Status          Authenticated Host Count
-----
1/ 1      Disabled         0
1/ 2      Enabled          0
1/ 3      Disabled         0
1/ 4      Disabled         0
1/ 5      Enabled          0
1/ 6      Disabled         0
1/ 7      Disabled         0
1/ 8      Disabled         0
1/ 9      Disabled         0
1/10     Disabled         0
1/11     Disabled         0
1/12     Disabled         0
1/13     Disabled         0
1/14     Disabled         0
1/15     Disabled         0
1/16     Disabled         0
1/17     Disabled         0
1/18     Disabled         0
1/19     Disabled         0
1/20     Disabled         0
1/21     Disabled         0
1/22     Disabled         0
1/23     Disabled         0
1/24     Disabled         0
1/25     Disabled         0
1/26     Disabled         0
1/27     Disabled         0
1/28     Disabled         0
Console#

```

Displaying Web Authentication Port Information

This switch can display web authentication information for all ports and connected hosts.

Command Attributes

- **Interface** – Indicates the ethernet port to query.
- **IP Address** – Indicates the IP address of each connected host.
- **Status** – Indicates the authorization status of each connected host.
- **Remaining Session Time (seconds)** – Indicates the remaining time until the current authorization session for the host expires.

3 Configuring the Switch

Web – Click Security, Web Authentication, Port Information.

Web Authentication Port Information

Interface Port 1

Query

IP Address	Status	Remaining Session Time (seconds)
------------	--------	----------------------------------

Refresh

Figure 3-59 Web Authentication Port Information

CLI – This example displays web authentication parameters for port 1/5.

```
Console#show web-auth interface ethernet 1/5                               4-134
Web Auth Status      : Enabled

Host Summary

IP address           Web-Auth-State Remaining-Session-Time
-----
Console#
```

Re-authenticating Web Authenticated Ports

The switch allows an administrator to manually force re-authentication of any web-authenticated host connected to any port.

Command Attributes

- **Interface** – Indicates the ethernet port to query.
- **Host IP** – Indicates the IP address of the host selected for re-authentication.

Web – Click Security, Web Authentication, Re-authentication.

Web Authentication Port Re-authentication

Interface Port 1

Query

Host IP (none)

Refresh Re-auth

Figure 3-60 Web Authentication Port Re-authentication

CLI – This example forces the re-authentication of all hosts connected to port 1/5.

```
Console#web-auth re-authenticate interface ethernet 1/5      4-135
Failed to reauth .
Console#
```

Network Access – MAC Address Authentication

Some devices connected to switch ports may not be able to support 802.1X authentication due to hardware or software limitations. This is often true for devices such as network printers, IP phones, and some wireless access points. The switch enables network access from these devices to be controlled by authenticating device MAC addresses with a central RADIUS server.

Note: MAC authentication, web authentication, 802.1X, and port security cannot be configured together on the same port. Only one security mechanism can be applied.

The Network Access feature controls host access to the network by authenticating its MAC address on the connected switch port. Traffic received from a specific MAC address is forwarded by the switch only if the source MAC address is successfully authenticated by a central RADIUS server. While authentication for a MAC address is in progress, all traffic is blocked until authentication is completed. On successful authentication, the RADIUS server may optionally assign VLAN settings for the switch port.

When enabled on a port interface, the authentication process sends a Password Authentication Protocol (PAP) request to a configured RADIUS server. The username and password are both equal to the MAC address being authenticated. On the RADIUS server, PAP username and passwords must be configured in the MAC address format XX-XX-XX-XX-XX-XX (all in upper case).

Authenticated MAC addresses are stored as dynamic entries in the switch secure MAC address table and are removed when the aging time expires. The maximum number of secure MAC addresses supported for the switch system is 1024.

Note: MAC authentication cannot be configured on trunk ports.

The RADIUS server may optionally return a VLAN identifier list to be applied to the switch port. The following attributes need to be configured on the RADIUS server.

- **Tunnel-Type** = VLAN
- **Tunnel-Medium-Type** = 802
- **Tunnel-Private-Group-ID** = 1u,2t [VLAN ID list]

The VLAN identifier list is carried in the RADIUS “Tunnel-Private-Group-ID” attribute. The VLAN list can contain multiple VLAN identifiers in the format “1u,2t,3u” where “u” indicates an untagged VLAN and “t” a tagged VLAN.

3 Configuring the Switch

Configuring the MAC Authentication Reauthentication Time

MAC address authentication is configured on a per-port basis, however there are two configurable parameters that apply globally to all ports on the switch.

Command Attributes

- **Authenticated Age** – The secure MAC address table aging time. This parameter setting is the same as switch MAC address table aging time and is only configurable from the Address Table, Aging Time web page (see page 3-136). (Default: 300 seconds)
- **MAC Authentication Reauthentication Time** – Sets the time period after which a connected MAC address must be reauthenticated. When the reauthentication time expires for a secure MAC address, it is reauthenticated with the RADIUS server. During the reauthentication process traffic through the port remains unaffected. (Default: 1800 seconds; Range: 120-1000000 seconds)

Web – Click Security, Network Access, Configuration.

Network Access Configuration	
Authenticated Age	300 seconds
MAC Authentication Reauthentication Time (120-1000000; default: 1800)	<input type="text" value="1800"/> seconds

Figure 3-61 Network Access Configuration

CLI – This example sets and displays the reauthentication time.

```
Console(config)#mac-authentication reauth-time 3000      4-126
Console(config)#exit
Console#show network-access interface ethernet 1/1      4-127
Global secure port information
Reauthentication Time           : 1800
-----
Port : 1/1
MAC Authentication              : Disabled
MAC Authentication Intrusion action : Block traffic
MAC Authentication Maximum MAC Counts : 1024
Maximum MAC Counts             : 2048
Dynamic VLAN Assignment        : Enabled
Guest VLAN                     : Disabled
Console#
```

Configuring MAC Authentication for Ports

Configures MAC authentication on switch ports, including setting the maximum MAC count, applying a MAC address filter, and enabling dynamic VLAN assignment.

Command Attributes

- **Mode** – Enables MAC authentication on a port. (Default: None)

- **Maximum MAC Count** – Sets the maximum number of MAC addresses that can be authenticated on a port. The maximum number of MAC addresses per port is 2048, and the maximum number of secure MAC addresses supported for the switch system is 1024. When the limit is reached, all new MAC addresses are treated as authentication failed. (Default: 2048; Range: 1 to 2048)
- **Guest VLAN** – Specifies the VLAN to be assigned to the port when MAC Authentication or 802.1X Authentication fails. The VLAN must already be created and active. (Default: Disabled; Range: 1 to 4092)
- **Dynamic VLAN** – Enables dynamic VLAN assignment for an authenticated port. When enabled, any VLAN identifiers returned by the RADIUS server are applied to the port, providing the VLANs have already been created on the switch. (GVRP is not used to create the VLANs.) The VLAN settings specified by the first authenticated MAC address are implemented for a port. Other authenticated MAC addresses on the port must have the same VLAN configuration, or they are treated as authentication failures. (Default: Enabled)
- **Dynamic QoS** – Enables the dynamic QoS feature for an authenticated port. (Default: Disabled)

Note: MAC authentication cannot be configured on trunk ports. Ports configured as trunk members are indicated on the Network Access Port Configuration page in the “Trunk” column.

Web – Click Security, Network Access, Port Configuration.

Port	Mode	Maximum MAC Count (1-2048)	Guest VLAN (1-4092, 0:Disabled)	Dynamic VLAN	Dynamic QoS	Trunk
1	None	2048	0	<input checked="" type="checkbox"/> Enabled	<input checked="" type="checkbox"/> Enabled	
2	MAC Authentication	2048	0	<input checked="" type="checkbox"/> Enabled	<input checked="" type="checkbox"/> Enabled	
3	None	2048	0	<input checked="" type="checkbox"/> Enabled	<input checked="" type="checkbox"/> Enabled	
4	None	2048	0	<input checked="" type="checkbox"/> Enabled	<input checked="" type="checkbox"/> Enabled	
5	None	2048	0	<input checked="" type="checkbox"/> Enabled	<input checked="" type="checkbox"/> Enabled	
6	None	2048	0	<input checked="" type="checkbox"/> Enabled	<input checked="" type="checkbox"/> Enabled	
7	None	2048	0	<input checked="" type="checkbox"/> Enabled	<input checked="" type="checkbox"/> Enabled	
8	None	2048	0	<input checked="" type="checkbox"/> Enabled	<input checked="" type="checkbox"/> Enabled	
9	None	2048	0	<input checked="" type="checkbox"/> Enabled	<input checked="" type="checkbox"/> Enabled	

Figure 3-62 Network Access Port Configuration

3 Configuring the Switch

CLI – This example configures MAC authentication for port 1.

```
Console(config)#interface ethernet 1/1
Console(config-if)#network-access mode mac-authentication 4-120
Console(config-if)#network-access max-mac-count 10 4-121
Console(config-if)#mac-authentication max-mac-count 24 4-122
Console(config-if)#network-access dynamic-vlan 4-123
Console(config-if)#network-access dynamic-qos 4-123
Console(config-if)#network-access guest-vlan 4-124
Console(config-if)#network-access link-detection 4-124
Console(config-if)#network-access link-detection link-up action trap4-125
Console(config-if)#end
Console#show network-access interface ethernet 1/1
Global secure port information
Reauthentication Time : 1800
-----
Port : 1/1
MAC Authentication : Enabled
MAC Authentication Intrusion action : Block traffic
MAC Authentication Maximum MAC Counts : 1024
Maximum MAC Counts : 2048
Dynamic VLAN Assignment : Enabled
Dynamic QoS Assignment : Enabled
Guest VLAN : Enabled
Link Detection : Enabled
Detection Mode : Link-up
Detection Action : Trap
Console#
```

Configuring Port Link Detection

The Port Link Detection feature can send an SNMP trap and/or shut down a port when a link event occurs.

Command Attributes

- **Port** – Indicates the port being configured.
- **Status** – Configures whether Link Detection is enabled or disabled for a port.
- **Condition** – The link event type which will trigger the port action.
 - Link Up – Only link up events will trigger the port action.
 - Link Down – Only link down events will trigger the port action.
 - Link Up and Down – All link up and link down events will trigger the port action.
- **Action** – The switch can respond in three ways to a link up or down trigger event.
 - **Trap** – An SNMP trap is sent.
 - **Trap and Shutdown** – An SNMP trap is sent and the port is shut down.
 - **Shutdown** – The port is shut down.
- **Trunk** – Indicates if the port is a trunk member.

Web – Click Security, Network Access, Port Link Detection Configuration. Modify the Status, Condition and Action. Click Apply.

Port Link Detection Configuration				
Port	Status	Condition	Action	Trunk
1	<input checked="" type="checkbox"/> Enabled	Link up	Trap	
2	<input checked="" type="checkbox"/> Enabled	Link down	Trap	
3	<input checked="" type="checkbox"/> Enabled	Link up and down	Trap	
4	<input checked="" type="checkbox"/> Enabled	Link up	Trap and Shutdown	
5	<input type="checkbox"/> Enabled	Link up	Shutdown	
6	<input type="checkbox"/> Enabled	Link up	Shutdown	
7	<input type="checkbox"/> Enabled	Link up	Shutdown	
8	<input type="checkbox"/> Enabled	Link up	Shutdown	
9	<input type="checkbox"/> Enabled	Link up	Shutdown	
10	<input type="checkbox"/> Enabled	Link up	Shutdown	
11	<input type="checkbox"/> Enabled	Link up	Shutdown	

Figure 3-63 Network Access Port Link Detection Configuration

CLI – This example configures Port Link Detection to send an SNMP trap for all link events on port 1.

```

Console(config)#interface ethernet 1/1                               4-166
Console(config-if)#network-access link-detection link-up-down
actiontrap                                                         4-126
Console(config-if)#

```

Displaying Secure MAC Address Information

Authenticated MAC addresses are stored in the secure MAC address table. Information on the secure MAC entries can be displayed and selected entries can be removed from the table.

Command Attributes

- **Network Access MAC Address Count** – The number of MAC addresses currently in the secure MAC address table.
- **Query By** – Specifies parameters to use in the MAC address query.
 - **Port** – Specifies a port interface.
 - **MAC Address** – Specifies a single MAC address information.
 - **Attribute** – Displays static or dynamic addresses.
 - **Address Table Sort Key** – Sorts the information displayed based on MAC address or port interface.
- **Unit/Port** – The port interface associated with a secure MAC address.
- **MAC Address** – The authenticated MAC address.
- **RADIUS Server** – The IP address of the RADIUS server that authenticated the MAC address.
- **Time** – The time when the MAC address was last authenticated.

3 Configuring the Switch

- **Attribute** – Indicates a static or dynamic address.
- **Remove** – Click the Remove button to remove selected MAC addresses from the secure MAC address table.

Web – Click Security, Network Access, MAC Address Information. Restrict the displayed addresses by port, MAC Address, or attribute, then select the method of sorting the displayed addresses. Click Query.

Network Access MAC Address Information

Network Access MAC Address Count

Query by:

<input type="checkbox"/> Port	<input type="text" value="1"/>
<input type="checkbox"/> MAC Address	<input type="text"/>
<input type="checkbox"/> Attribute	<input type="text" value="Static"/>
Address Table Sort Key	<input type="text" value="Address"/>

Unit/port	MAC Address	RADIUS Server	Time	Attribute
-----------	-------------	---------------	------	-----------

Figure 3-64 Network Access MAC Address Information

CLI – This example displays all entries currently in the secure MAC address table.

```
Console#show network-access mac-address-table 4-128
-----
Port  MAC-Address      RADIUS-Server  Attribute  Time
-----
1/1   00-00-01-02-03-04  172.155.120.17 Static     00d06h32m50s
1/1   00-00-01-02-03-05  172.155.120.17 Dynamic    00d06h33m20s
1/1   00-00-01-02-03-06  172.155.120.17 Static     00d06h35m10s
1/3   00-00-01-02-03-07  172.155.120.17 Dynamic    00d06h34m20s
Console#
```

MAC Authentication

Each port's MAC authentication settings are configured independently.

Configuring MAC authentication parameters for ports

Use the MAC Authentication Port Configuration page to designate MAC authentication maximum MAC counts and the intrusion action for each port.

Command Attributes

- **Port** – Indicates the port being configured.

- **Status** – Indicates whether MAC Authentication is enabled or disabled for the port. See “Configuring MAC Authentication for Ports” on page 3-94. The following parameters are unavailable for modification if MAC Authentication is not enabled for the port.
- **Max MAC Count** – The maximum allowed amount of MAC authenticated MAC addresses on the port. (Default: 1024; Range: 1-1024)
- **Intrusion Action** – The switch can respond in two ways to an intrusion.
 - **Block Traffic** – All traffic for the unauthenticated host is blocked.
 - **Pass Traffic** – All traffic for the unauthenticated host is allowed.
- **Trunk** – Indicates if the port is a trunk member.

Web – Click Security, MAC Authentication. Modify the Maximum MAC Count and Intrusion Action. Click Apply.

Port	Status	Maximum MAC Count (1-1024)	Intrusion Action	Trunk
1	Disabled	1024	Block traffic	
2	Enabled	1024	Block traffic	
3	Disabled	1024	Block traffic	
4	Disabled	1024	Block traffic	
5	Disabled	1024	Block traffic	
6	Disabled	1024	Block traffic	
7	Disabled	1024	Block traffic	
8	Disabled	1024	Block traffic	
9	Disabled	1024	Block traffic	
10	Disabled	1024	Block traffic	

Figure 3-65 MAC Authentication Port Configuration

CLI – This example configures the maximum MAC count to 32 and sets the intrusion action to block all traffic for port 1.

```

Console(config)#interface ethernet 1/1                               4-166
Console(config-if)#mac-authentication max-mac-count 24             4-122
Console(config-if)#mac-authentication intrusion-action block-traffic 4-122
Console(config-if)#

```

Access Control Lists

Access Control Lists (ACL) provide packet filtering for IP frames (based on address, protocol, Layer 4 protocol port number or TCP control code) or any frames (based on MAC address or Ethernet type). To filter incoming packets, first create an access list, add the required rules, and then bind the list to a specific port.

Configuring Access Control Lists

An ACL is a sequential list of permit or deny conditions that apply to IP addresses, MAC addresses, or other more specific criteria. This switch tests ingress or egress packets against the conditions in an ACL one by one. A packet will be accepted as soon as it matches a permit rule, or dropped as soon as it matches a deny rule. If no rules match for a list of all permit rules, the packet is dropped; and if no rules match for a list of all deny rules, the packet is accepted.

Command Usage

The following restrictions apply to ACLs:

- Each ACL can have up to 100 rules.
- However, due to resource restrictions, the average number of rules bound to the ports should not exceed 20.
- When an ACL is bound to an interface as an egress filter, all entries in the ACL must be deny rules. Otherwise, the bind operation will fail.
- The switch does not support the explicit “deny any any” rule for the egress IP ACL. If these rules are included in ACL, and you attempt to bind the ACL to an interface for egress checking, the bind operation will fail.

The order in which active ACLs are checked is as follows:

1. User-defined rules in the Egress IP ACL for egress ports.
2. User-defined rules in the Ingress IP ACL for ingress ports.
3. Explicit default rule (permit any any) in the ingress IP ACL for ingress ports.
4. If no explicit rule is matched, the implicit default is permit all.

Setting the ACL Name and Type

Use the ACL Configuration page to designate the name and type of an ACL.

Command Attributes

- **Name** – Name of the ACL. (Maximum length: 15 characters)
- **Type** – There are three filtering modes:
 - **Standard** – IP ACL mode that filters packets based on the source IP address.
 - **Extended** – IP ACL mode that filters packets based on source or destination IP address, as well as protocol type and protocol port number.
 - **MAC** – MAC ACL mode that filters packets based on the source or destination

MAC address and the Ethernet frame type (RFC 1060).

Web – Select Security, ACL, Configuration. Enter an ACL name in the Name field, select the list type (IP Standard, IP Extended, or MAC), and click Add to open the configuration page for the new list.

ACL Configuration

Type	Name	Remove	Edit
------	------	--------	------

Name	
Type	Standard ▼

Add

Figure 3-66 Selecting ACL Type

CLI – This example creates a standard IP ACL named david.

```
Console(config)#access-list ip standard david
Console(config-std-acl)#
```

4-139

Configuring a Standard IP ACL

Command Attributes

- **Action** – An ACL can contain any combination of permit or deny rules.
- **Address Type** – Specifies the source IP address. Use “Any” to include all possible addresses, “Host” to specify a specific host address in the Address field, or “IP” to specify a range of addresses with the Address and SubMask fields. (Options: Any, Host, IP; Default: Any)
- **IP Address** – Source IP address.
- **Subnet Mask** – A subnet mask containing four integers from 0 to 255, each separated by a period. The mask uses 1 bits to indicate “match” and 0 bits to indicate “ignore.” The mask is bitwise ANDed with the specified source IP address, and compared with the address for each IP packet entering the port(s) to which this ACL has been assigned.

Web – Specify the action (i.e., Permit or Deny). Select the address type (Any, Host, or IP). If you select “Host,” enter a specific address. If you select “IP,” enter a subnet address and the mask for an address range. Then click Add.

3 Configuring the Switch

Standard ACL

Name: Standard ACL

Action	IP Address	Subnet Mask	Remove
--------	------------	-------------	--------

Action	Permit
Address Type	Any
IP Address	0.0.0.0
Subnet Mask	0.0.0.0

Add

Figure 3-67 Configuring Standard IP ACLs

CLI – This example configures one permit rule for the specific address 10.1.1.21 and another rule for the address range 168.92.16.x – 168.92.31.x using a bitmask.

```
Console(config-std-acl) #permit host 10.1.1.21 4-140
Console(config-std-acl) #permit 168.92.16.0 255.255.240.0
Console(config-std-acl) #
```

Configuring an Extended IP ACL

Command Attributes

- **Action** – An ACL can contain any combination of permit or deny rules.
- **Source/Destination Address Type** – Specifies the source or destination IP address. Use “Any” to include all possible addresses, “Host” to specify a specific host address in the Address field, or “IP” to specify a range of addresses with the Address and SubMask fields. (Options: Any, Host, IP; Default: Any)
- **Source/Destination IP Address** – Source or destination IP address.
- **Source/Destination Subnet Mask** – Subnet mask for source or destination address.
- **Service Type** – Packet priority settings based on the following criteria:
 - **Precedence** – IP precedence level. (Range: 0-7)
 - **TOS** – Type of Service level. (Range: 0-15)
 - **DSCP** – DSCP priority level. (Range: 0-63)
- **Protocol** – Specifies the protocol type to match as TCP, UDP or Others, where others indicates a specific protocol number (0-255). (Options: TCP, UDP, Others; Default: TCP)
- **Source/Destination Port** – Source/destination port number for the specified protocol type. (Range: 0-65535)
- **Source/Destination Port Bitmask** – Decimal number representing the port bits to match. (Range: 0-65535)

- **Control Code** – Decimal number (representing a bit string) that specifies flag bits in byte 14 of the TCP header. (Range: 0-63)
- **Control Code Bit Mask** – Decimal number representing the code bits to match.

The control bitmask is a decimal number (for an equivalent binary bit mask) that is applied to the control code. Enter a decimal number, where the equivalent binary bit “1” means to match a bit and “0” means to ignore a bit. The following bits may be specified:

- 1 (fin) – Finish
- 2 (syn) – Synchronize
- 4 (rst) – Reset
- 8 (psh) – Push
- 16 (ack) – Acknowledgement
- 32 (urg) – Urgent pointer

For example, use the code value and mask below to catch packets with the following flags set:

- SYN flag valid, use control-code 2, control bitmask 2
- Both SYN and ACK valid, use control-code 18, control bitmask 18
- SYN valid and ACK invalid, use control-code 2, control bitmask 18

3 Configuring the Switch

Web – Specify the action (i.e., Permit or Deny). Specify the source and/or destination addresses. Select the address type (Any, Host, or IP). If you select “Host,” enter a specific address. If you select “IP,” enter a subnet address and the mask for an address range. Set any other required criteria, such as service type, protocol type, or TCP control code. Then click Add.

Extended ACL

Name: Extended ACL

Action	Source IP Address	Source Subnet Mask	Destination IP Address	Destination Subnet Mask	TOS	Precedence	DSCP	Protocol	Source Port	Source Port Bit Mask	Destination Port	Destination Port Bit Mask	Control Code	Control Code Bit Mask	Remove
Action	Permit														
Source Address Type	Any														
Source IP Address	0.0.0.0														
Source Subnet Mask	0.0.0.0														
Destination Address Type	Any														
Destination IP Address	0.0.0.0														
Destination Subnet Mask	0.0.0.0														
Service Type	<input checked="" type="radio"/> TOS (0-15): <input type="text"/> Precedence (0-7): <input type="text"/> <input type="radio"/> DSCP (0-63): <input type="text"/>														
Protocol	<input checked="" type="radio"/> TCP (6) <input type="radio"/> UDP (17) <input type="radio"/> Others: <input type="text"/>														
Source Port (0-65535)	<input type="text"/>														
Source Port Bit Mask (0-65535)	<input type="text"/>														
Destination Port (0-65535)	<input type="text"/>														
Destination Port Bit Mask (0-65535)	<input type="text"/>														
Control Code (0-63)	<input type="text"/>														
Control Code Bit Mask (0-63)	<input type="text"/>														
Add															

Figure 3-68 Configuring Extended IP ACLs

CLI – This example adds two rules:

- (1) Accept any incoming packets if the source address is in subnet 10.7.1.x. For example, if the rule is matched; i.e., the rule (10.7.1.0 & 255.255.255.0) equals the masked address (10.7.1.2 & 255.255.255.0), the packet passes through.
- (2) Allow TCP packets from class C addresses 192.168.1.0 to any destination address when set for destination TCP port 80 (i.e., HTTP).

```

Console(config-ext-acl)#permit 10.7.1.1 255.255.255.0 any
Console(config-ext-acl)#permit tcp 192.168.1.0 255.255.255.0 any
destination-port 80
Console(config-std-acl)#
  
```

4-140

Configuring a MAC ACL

Command Attributes

- **Action** – An ACL can contain any combination of permit or deny rules.
- **Source/Destination Address Type** – Use “Any” to include all possible addresses, “Host” to indicate a specific MAC address, or “MAC” to specify an address range with the Address and Bitmask fields. (Options: Any, Host, MAC; Default: Any)
- **Source/Destination MAC Address** – Source or destination MAC address.
- **Source/Destination Bitmask** – Hexadecimal mask for source or destination MAC address.
- **VID** – VLAN ID. (Range: 1-4094)
- **VID Mask** – VLAN bitmask. (Range: 1-4095)
- **Ethernet Type** – This option can only be used to filter Ethernet II formatted packets. (Range: 600-fff hex.)

A detailed listing of Ethernet protocol types can be found in RFC 1060. A few of the more common types include 0800 (IP), 0806 (ARP), 8137 (IPX).

- **Ethernet Type Bitmask** – Protocol bitmask. (Range: 600-fff hex.)
- **Packet Format** – This attribute includes the following packet types:
 - **Any** – Any Ethernet packet type.
 - **Untagged-eth2** – Untagged Ethernet II packets.
 - **Untagged-802.3** – Untagged Ethernet 802.3 packets.
 - **Tagged-802.3** – Tagged Ethernet 802.3 packets.
 - **Tagged-802.3** – Tagged Ethernet 802.3 packets.

Command Usage

Egress MAC ACLs only work for destination-mac-known packets, not for multicast, broadcast, or destination-mac-unknown packets.

3 Configuring the Switch

Web – Specify the action (i.e., Permit or Deny). Specify the source and/or destination addresses. Select the address type (Any, Host, or MAC). If you select "Host," enter a specific address (e.g., 11-22-33-44-55-66). If you select "MAC," enter a base address and a hexadecimal bitmask for an address range. Set any other required criteria, such as VID, Ethernet type, or packet format. Then click Add.

MAC ACL

Name: Mac

Action	Source MAC Address	Source Bit Mask	Destination MAC Address	Destination Bit Mask	VID	VID Bit Mask	Ethernet Type	Ethernet Type Bit Mask	Packet Format	Remove
Action	Permit									
Source Address Type	Any									
Source MAC Address	00-00-00-00-00-00									
Source Bit Mask	00-00-00-00-00-00									
Destination Address Type	Any									
Destination MAC Address	00-00-00-00-00-00									
Destination Bit Mask	00-00-00-00-00-00									
VID										
VID Bit Mask										
Ethernet Type										
Ethernet Type Bit Mask										
Packet Format	Any									
<input type="button" value="Add"/>										

Figure 3-69 Configuring MAC ACLs

CLI – This example configures one permit rule for all source mac addresses to communicate with all destination mac addresses on VLAN 12, and another permit rule for source mac address to communicate with all destination mac addresses.

```
Console(config-mac-acl)#permit any any vid 12 4095 4-145
Console(config-mac-acl)#permit host 00-10-b5-e9-52-79 any
Console(config-mac-acl)#
```

Binding a Port to an Access Control List

After configuring the Access Control Lists (ACL), you can bind the ports that need to filter traffic to the appropriate ACLs. You can assign one IP access list to any port.

Command Usage

- Each ACL can have up to 100 rules.
- This switch supports ACLs for ingress filtering only. However, you only bind one IP ACL to any port for ingress filtering. In other words, only one ACL can be bound to an interface - Ingress IP ACL.

Command Attributes

- **Port** – Fixed port or SFP module. (Range: 1-28/52)
- **IP** – Specifies the IP ACL to bind to a port.
- **MAC** – Specifies the MAC ACL to bind to a port.
- **IN** – ACL for ingress packets.

Web – Click Security, ACL, Port Binding. Click Edit to open the configuration page for the ACL type. Mark the Enable field for the port you want to bind to an ACL for ingress or egress traffic, select the required ACL from the drop-down list, then click Apply.

ACL Port Binding

Port	IP		MAC	
	IN	OUT	IN	OUT
1	<input type="checkbox"/> Enabled (none)	<input type="checkbox"/> Enabled (none)	<input type="checkbox"/> Enabled (none)	<input type="checkbox"/> Enabled (none)
2	<input type="checkbox"/> Enabled (none)	<input type="checkbox"/> Enabled (none)	<input type="checkbox"/> Enabled (none)	<input type="checkbox"/> Enabled (none)
3	<input type="checkbox"/> Enabled (none)	<input type="checkbox"/> Enabled (none)	<input type="checkbox"/> Enabled (none)	<input type="checkbox"/> Enabled (none)
4	<input type="checkbox"/> Enabled (none)	<input type="checkbox"/> Enabled (none)	<input type="checkbox"/> Enabled (none)	<input type="checkbox"/> Enabled (none)
5	<input type="checkbox"/> Enabled (none)	<input type="checkbox"/> Enabled (none)	<input type="checkbox"/> Enabled (none)	<input type="checkbox"/> Enabled (none)
6	<input type="checkbox"/> Enabled (none)	<input type="checkbox"/> Enabled (none)	<input type="checkbox"/> Enabled (none)	<input type="checkbox"/> Enabled (none)
7	<input type="checkbox"/> Enabled (none)	<input type="checkbox"/> Enabled (none)	<input type="checkbox"/> Enabled (none)	<input type="checkbox"/> Enabled (none)
8	<input type="checkbox"/> Enabled (none)	<input type="checkbox"/> Enabled (none)	<input type="checkbox"/> Enabled (none)	<input type="checkbox"/> Enabled (none)
9	<input type="checkbox"/> Enabled (none)	<input type="checkbox"/> Enabled (none)	<input type="checkbox"/> Enabled (none)	<input type="checkbox"/> Enabled (none)
10	<input type="checkbox"/> Enabled (none)	<input type="checkbox"/> Enabled (none)	<input type="checkbox"/> Enabled (none)	<input type="checkbox"/> Enabled (none)
11	<input type="checkbox"/> Enabled (none)	<input type="checkbox"/> Enabled (none)	<input type="checkbox"/> Enabled (none)	<input type="checkbox"/> Enabled (none)
12	<input type="checkbox"/> Enabled (none)	<input type="checkbox"/> Enabled (none)	<input type="checkbox"/> Enabled (none)	<input type="checkbox"/> Enabled (none)
13	<input type="checkbox"/> Enabled (none)	<input type="checkbox"/> Enabled (none)	<input type="checkbox"/> Enabled (none)	<input type="checkbox"/> Enabled (none)
14	<input type="checkbox"/> Enabled (none)	<input type="checkbox"/> Enabled (none)	<input type="checkbox"/> Enabled (none)	<input type="checkbox"/> Enabled (none)
15	<input type="checkbox"/> Enabled (none)	<input type="checkbox"/> Enabled (none)	<input type="checkbox"/> Enabled (none)	<input type="checkbox"/> Enabled (none)
16	<input type="checkbox"/> Enabled (none)	<input type="checkbox"/> Enabled (none)	<input type="checkbox"/> Enabled (none)	<input type="checkbox"/> Enabled (none)
17	<input type="checkbox"/> Enabled (none)	<input type="checkbox"/> Enabled (none)	<input type="checkbox"/> Enabled (none)	<input type="checkbox"/> Enabled (none)
18	<input type="checkbox"/> Enabled (none)	<input type="checkbox"/> Enabled (none)	<input type="checkbox"/> Enabled (none)	<input type="checkbox"/> Enabled (none)

Figure 3-70 Configuring ACL Port Binding

CLI – This example assigns an IP access list to port 1, and an IP access list to port 3.

```

Console(config)#interface ethernet 1/1
Console(config-if)#ip access-group david in
Console(config-if)#exit
Console(config)#interface ethernet 1/3
Console(config-if)#ip access-group david in
Console(config-if)#

```

Filtering IP Addresses for Management Access

You can create a list of up to 16 IP addresses or IP address groups that are allowed management access to the switch through the web interface, SNMP, or Telnet.

Command Usage

- The management interfaces are open to all IP addresses by default. Once you add

3 Configuring the Switch

an entry to a filter list, access to that interface is restricted to the specified addresses.

- If anyone tries to access a management interface on the switch from an invalid address, the switch will reject the connection, enter an event message in the system log, and send a trap message to the trap manager.
- IP address can be configured for SNMP, web and Telnet access respectively. Each of these groups can include up to five different sets of addresses, either individual addresses or address ranges.
- When entering addresses for the same group (i.e., SNMP, web or Telnet), the switch will not accept overlapping address ranges. When entering addresses for different groups, the switch will accept overlapping address ranges.
- You cannot delete an individual address from a specified range. You must delete the entire range, and reenter the addresses.
- You can delete an address range just by specifying the start address, or by specifying both the start address and end address.

Command Attributes

- **Web IP Filter** – Configures IP address(es) for the web group.
- **SNMP IP Filter** – Configures IP address(es) for the SNMP group.
- **Telnet IP Filter** – Configures IP address(es) for the Telnet group.
- **IP Filter List** – IP address which are allowed management access to this interface.
- **Start IP Address** – A single IP address, or the starting address of a range.
- **End IP Address** – The end address of a range.
- **Add/Remove Filtering Entry** – Adds/removes an IP address from the list.

Web – Click Security, IP Filter. Enter the IP addresses or range of addresses that are allowed management access to an interface, and click Add Web IP Filtering Entry to update the filter list.

The screenshot shows a web-based configuration interface for IP filtering. At the top, it is titled "IP Filter". Below this, there is a section for "Web IP Filter". This section contains a table with two columns: "Web IP Filter List" and a value field. The value field currently contains "(none)". Below the table are two input fields: "Start IP Address" and "End IP Address". At the bottom of the section are two buttons: "Add Web IP Filtering Entry" and "Remove Web IP Filtering Entry".

Figure 3-71 Creating an IP Filter List

CLI – This example allows SNMP access for a specific client.

```

Console(config)#management snmp-client 10.1.2.3                               4-39
Console(config)#end
Console#show management all-client
Management IP Filter
  HTTP-Client:
    Start IP address  End IP address
-----
SNMP-Client:
  Start IP address  End IP address
-----
1. 10.1.2.3        10.1.2.3
TELNET-Client:
  Start IP address  End IP address
-----
Console#

```

Port Configuration

Displaying Connection Status

You can use the Port Information or Trunk Information pages to display the current connection status, including link state, speed/duplex mode, flow control, and auto-negotiation.

Field Attributes (Web)

- **Name** – Interface label.
- **Type** – Indicates the port type. (100BASE-TX, 1000BASE-T, or SFP)
- **Admin Status** – Shows if the interface is enabled or disabled.
- **Oper Status** – Indicates if the link is Up or Down.
- **Speed Duplex Status** – Shows the current speed and duplex mode. (Auto, or fixed choice)
- **Flow Control Status** – Indicates the type of flow control currently in use. (IEEE 802.3x, Back-Pressure or None)
- **Autonegotiation** – Shows if auto-negotiation is enabled or disabled.
- **Media Type**⁵ – Media type used for the combo ports. (Options: Copper-Forced, SFP-Forced, or SFP-Preferred-Auto; Default: SFP-Preferred-Auto)
- **Trunk Member**⁶ – Shows if port is a trunk member.
- **Creation**⁷ – Shows if a trunk is manually configured or dynamically set via LACP.

Web – Click Port, Port Information or Trunk Information.

Port Information								
Port Name	Type	Admin Status	Oper Status	Speed Duplex Status	Flow Control Status	Autonegotiation	Media Type	Trunk Member
1	100Base-TX	Enabled	Down	10half	None	Enabled	None	
2	100Base-TX	Enabled	Down	10half	None	Enabled	None	
3	100Base-TX	Enabled	Down	10half	None	Enabled	None	
4	100Base-TX	Enabled	Down	10half	None	Enabled	None	
5	100Base-TX	Enabled	Up	100full	None	Enabled	None	
6	100Base-TX	Enabled	Down	10half	None	Enabled	None	
7	100Base-TX	Enabled	Down	10half	None	Enabled	None	
8	100Base-TX	Enabled	Down	10half	None	Enabled	None	

Figure 3-72 Displaying Port/Trunk Information

5. Port information only.

6. Port information only.

7. Trunk information only.

Field Attributes (CLI)

Basic Information:

- **Port type** – Indicates the port type. (100BASE-TX, 1000BASE-T, or SFP)
- **MAC address** – The physical layer address for this port. (To access this item on the web, see “Setting the Switch’s IP Address” on page 3-16.)

Configuration:

- **Name** – Interface label.
- **Port admin** – Shows if the interface is enabled or disabled (i.e., up or down).
- **Speed-duplex** – Shows the current speed and duplex mode. (Auto, or fixed choice)
- **Capabilities** – Specifies the capabilities to be advertised for a port during auto-negotiation. (To access this item on the web, see “Configuring Interface Connections” on page 3-48.) The following capabilities are supported.
 - **10half** - Supports 10 Mbps half-duplex operation
 - **10full** - Supports 10 Mbps full-duplex operation
 - **100half** - Supports 100 Mbps half-duplex operation
 - **100full** - Supports 100 Mbps full-duplex operation
 - **1000full** - Supports 1000 Mbps full-duplex operation
 - **Sym** - Transmits and receives pause frames for flow control
 - **FC** - Supports flow control
- **Broadcast storm** – Shows if broadcast storm control is enabled or disabled.
- **Broadcast storm limit** – Shows the broadcast storm threshold. (240-1488100 packets per second)
- **Flow control** – Shows if flow control is enabled or disabled.
- **LACP** – Shows if LACP is enabled or disabled.
- **Port Security** – Shows if port security is enabled or disabled.
- **Max MAC count** – Shows the maximum number of MAC address that can be learned by a port. (0 - 1024 addresses)
- **Port security action** – Shows the response to take when a security violation is detected. (shutdown, trap, trap-and-shutdown, or none)

Current Status:

- **Link Status** – Indicates if the link is up or down.
- **Port Operation Status** – Provides detailed information on port state. (Displayed only when the link is up.)
- **Operation speed-duplex** – Shows the current speed and duplex mode.
- **Flow control type** – Indicates the type of flow control currently in use. (IEEE 802.3x, Back-Pressure or none)

3 Configuring the Switch

CLI – This example shows the connection status for Port 5.

```
Console#show interfaces status ethernet 1/5 4-173
Information of Eth 1/5
Basic information:
  Port type:                100TX
  Mac address:              00-12-CF-12-34-61
Configuration:
  Name:
  Port admin:              Up
  Speed-duplex:            Auto
  Capabilities:            10half, 10full, 100half, 100full
  Broadcast storm:        Enabled
  Broadcast storm limit:   500 packets/second
  Flow control:            Disabled
  Lacp:                    Disabled
  Port security:           Disabled
  Max MAC count:           0
  Port security action:    None
Current status:
  Link status:             Down
  Operation speed-duplex:  100full
  Flow control type:       None
Console#
```

Configuring Interface Connections

You can use the Port Configuration or Trunk Configuration page to enable/disable an interface, set auto-negotiation and the interface capabilities to advertise, or manually fix the speed, duplex mode, and flow control.

Command Attributes

- **Name** – Allows you to label an interface. (Range: 1-64 characters)
- **Admin** – Allows you to manually disable an interface. You can disable an interface due to abnormal behavior (e.g., excessive collisions), and then reenable it after the problem has been resolved. You may also disable an interface for security reasons.
- **Speed/Duplex** – Allows you to manually set the port speed and duplex mode. (i.e., with auto-negotiation disabled)
- **Flow Control** – Allows automatic or manual selection of flow control.
- **Autonegotiation (Port Capabilities)** – Allows auto-negotiation to be enabled/disabled. When auto-negotiation is enabled, you need to specify the capabilities to be advertised. When auto-negotiation is disabled, you can force the settings for speed, mode, and flow control. The following capabilities are supported.
 - **10half** - Supports 10 Mbps half-duplex operation
 - **10full** - Supports 10 Mbps full-duplex operation
 - **100half** - Supports 100 Mbps half-duplex operation
 - **100full** - Supports 100 Mbps full-duplex operation
 - **1000full** (Combo ports only) - Supports 1000 Mbps full-duplex operation

(Default: Autonegotiation enabled; Advertised capabilities for 100BASE-TX – 10half, 10full, 100half, 100full; 1000BASE-T – 10half, 10full, 100half, 100full, 1000full; 1000BASE-SX/LX/LH – 1000full)

- **Media Type** – Media type used for the combo ports. (Options: Copper-Forced, SFP-Forced, or SFP-Preferred-Auto; Default: SFP-Preferred-Auto)
- **Trunk** – Indicates if a port is a member of a trunk. To create trunks and select port members, see “Creating Trunk Groups” on page 3-114.

- Notes:**
1. Auto-negotiation must be disabled before you can configure or force the interface to use the Speed/Duplex Mode or Flow Control options.
 2. 1000full operation cannot be forced. The Gigabit Combo ports can only operate at 1000full when auto-negotiation is enabled.

Web – Click Port, Port Configuration or Trunk Configuration. Modify the required interface settings, and click Apply.

Port Configuration									
Port	Name	Admin	Speed Duplex	Flow Control	Autonegotiation			Media Type	Trunk
1		<input checked="" type="checkbox"/> Enabled	100full	<input type="checkbox"/> Enabled	<input checked="" type="checkbox"/> Enabled	<input checked="" type="checkbox"/> 10h <input checked="" type="checkbox"/> 10f <input checked="" type="checkbox"/> 100h <input checked="" type="checkbox"/> 100f <input type="checkbox"/> 1000h <input type="checkbox"/> 1000f <input type="checkbox"/> 10Gh <input type="checkbox"/> 10Gf	None		
2		<input checked="" type="checkbox"/> Enabled	100full	<input type="checkbox"/> Enabled	<input checked="" type="checkbox"/> Enabled	<input checked="" type="checkbox"/> 10h <input checked="" type="checkbox"/> 10f <input checked="" type="checkbox"/> 100h <input checked="" type="checkbox"/> 100f <input type="checkbox"/> 1000h <input type="checkbox"/> 1000f <input type="checkbox"/> 10Gh <input type="checkbox"/> 10Gf	None		
3		<input checked="" type="checkbox"/> Enabled	100full	<input type="checkbox"/> Enabled	<input checked="" type="checkbox"/> Enabled	<input checked="" type="checkbox"/> 10h <input checked="" type="checkbox"/> 10f <input checked="" type="checkbox"/> 100h <input checked="" type="checkbox"/> 100f <input type="checkbox"/> 1000h <input type="checkbox"/> 1000f <input type="checkbox"/> 10Gh <input type="checkbox"/> 10Gf	None		
4		<input checked="" type="checkbox"/> Enabled	100full	<input type="checkbox"/> Enabled	<input checked="" type="checkbox"/> Enabled	<input checked="" type="checkbox"/> 10h <input checked="" type="checkbox"/> 10f <input checked="" type="checkbox"/> 100h <input checked="" type="checkbox"/> 100f <input type="checkbox"/> 1000h <input type="checkbox"/> 1000f <input type="checkbox"/> 10Gh <input type="checkbox"/> 10Gf	None		
5		<input checked="" type="checkbox"/> Enabled	100full	<input type="checkbox"/> Enabled	<input checked="" type="checkbox"/> Enabled	<input checked="" type="checkbox"/> 10h <input checked="" type="checkbox"/> 10f <input checked="" type="checkbox"/> 100h <input checked="" type="checkbox"/> 100f <input type="checkbox"/> 1000h <input type="checkbox"/> 1000f <input type="checkbox"/> 10Gh <input type="checkbox"/> 10Gf	None		
6		<input checked="" type="checkbox"/> Enabled	100full	<input type="checkbox"/> Enabled	<input checked="" type="checkbox"/> Enabled	<input checked="" type="checkbox"/> 10h <input checked="" type="checkbox"/> 10f <input checked="" type="checkbox"/> 100h <input checked="" type="checkbox"/> 100f <input type="checkbox"/> 1000h <input type="checkbox"/> 1000f <input type="checkbox"/> 10Gh <input type="checkbox"/> 10Gf	None		
7		<input checked="" type="checkbox"/> Enabled	100full	<input type="checkbox"/> Enabled	<input checked="" type="checkbox"/> Enabled	<input checked="" type="checkbox"/> 10h <input checked="" type="checkbox"/> 10f <input checked="" type="checkbox"/> 100h <input checked="" type="checkbox"/> 100f <input type="checkbox"/> 1000h <input type="checkbox"/> 1000f <input type="checkbox"/> 10Gh <input type="checkbox"/> 10Gf	None		
8		<input checked="" type="checkbox"/> Enabled	100full	<input type="checkbox"/> Enabled	<input checked="" type="checkbox"/> Enabled	<input checked="" type="checkbox"/> 10h <input checked="" type="checkbox"/> 10f <input checked="" type="checkbox"/> 100h <input checked="" type="checkbox"/> 100f <input type="checkbox"/> 1000h <input type="checkbox"/> 1000f <input type="checkbox"/> 10Gh <input type="checkbox"/> 10Gf	None		

Figure 3-73 Port/Trunk Configuration

CLI – Select the interface, and then enter the required settings.

```

Console(config)#interface ethernet 1/13 4-166
Console(config-if)#description RD SW#13 4-167
Console(config-if)#shutdown 4-171
.
Console(config-if)#no shutdown
Console(config-if)#no negotiation 4-168
Console(config-if)#speed-duplex 100half 4-167
Console(config-if)#flowcontrol 4-170
.
Console(config-if)#negotiation
Console(config-if)#capabilities 100half 4-169
Console(config-if)#capabilities 100full
Console(config-if)#capabilities flowcontrol

```

Creating Trunk Groups

You can create multiple links between devices that work as one virtual, aggregate link. A port trunk offers a dramatic increase in bandwidth for network segments where bottlenecks exist, as well as providing a fault-tolerant link between two devices. You can create up to four trunks at a time.

The switch supports both static trunking and dynamic Link Aggregation Control Protocol (LACP). Static trunks have to be manually configured at both ends of the link, and the switches must comply with the Cisco EtherChannel standard. On the other hand, LACP configured ports can automatically negotiate a trunked link with LACP-configured ports on another device. You can configure any number of ports on the switch as LACP, as long as they are not already configured as part of a static trunk. If ports on another device are also configured as LACP, the switch and the other device will negotiate a trunk link between them. If an LACP trunk consists of more than eight ports, all other ports will be placed in a standby mode. Should one link in the trunk fail, one of the standby ports will automatically be activated to replace it.

Command Usage

Besides balancing the load across each port in the trunk, the other ports provide redundancy by taking over the load if a port in the trunk fails. However, before making any physical connections between devices, use the web interface or CLI to specify the trunk on the devices at both ends. When using a port trunk, take note of the following points:

- Finish configuring port trunks before you connect the corresponding network cables between switches to avoid creating a loop.
- You can create up to eight trunks on a switch, with up to eight ports per trunk.
- The ports at both ends of a connection must be configured as trunk ports.
- When configuring static trunks on switches of different types, they must be compatible with the Cisco EtherChannel standard.
- The ports at both ends of a trunk must be configured in an identical manner, including communication mode (i.e., speed, duplex mode and flow control), VLAN assignments, and CoS settings.
- All the ports in a trunk have to be treated as a whole when moved from/to, added or deleted from a VLAN.
- STP, VLAN, and IGMP settings can only be made for the entire trunk.

Statically Configuring a Trunk

Command Usage

- When configuring static trunks, you may not be able to link switches of different types, depending on the manufacturer's implementation. However, note that the static trunks on this switch are Cisco EtherChannel compatible.
- To avoid creating a loop in the network, be sure you add a static trunk via the configuration interface before connecting the ports, and also disconnect the ports before removing a static trunk via the configuration interface.

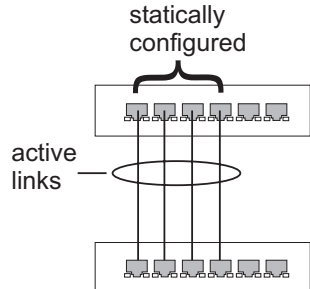

Command Attributes

- **Member List** (Current) – Shows configured trunks (Trunk ID, Unit, Port).
- **New** – Includes entry fields for creating new trunks.
 - **Trunk** – Trunk identifier. (Range: 1-8)
 - **Port** – Port identifier.

Web – Click Port, Trunk Membership. Enter a trunk ID of 1-8 in the Trunk field, select any of the switch ports from the scroll-down port list, and click Add. After you have completed adding ports to the member list, click Apply.

Trunk Membership

Member List:

Current: (none) New:

<<Add

Trunk {1-8}

Remove

Port

1

▼

Figure 3-74 Configuring Static Trunks

3 Configuring the Switch

CLI – This example creates trunk 2 with ports 1 and 2. Just connect these ports to two static trunk ports on another switch to form a trunk.

```
Console(config)#interface port-channel 2          4-166
Console(config-if)#exit
Console(config)#interface ethernet 1/1          4-166
Console(config-if)#channel-group 2             4-181
Console(config-if)#exit
Console(config)#interface ethernet 1/2
Console(config-if)#channel-group 2
Console(config-if)#end
Console#show interfaces status port-channel 2   4-173
Information of Trunk 2
Basic information:
  Port type:          100TX
  Mac address:       00-12-CF-12-34-84
Configuration:
  Name:
  Port admin:       Up
  Speed-duplex:    Auto
  Capabilities:    10half, 10full, 100half, 100full
  Flow control:    Disabled
  Port security:   Disabled
  Max MAC count:   0
Current status:
  Created by:      User
  Link status:     Up
  Port operation status: Up
  Operation speed-duplex: 100full
  Flow control type: None
  Member Ports:   Eth1/1, Eth1/2,
Console#
```

Enabling LACP on Selected Ports

Command Usage

- To avoid creating a loop in the network, be sure you enable LACP before connecting the ports, and also disconnect the ports before disabling LACP.
- If the target switch has also enabled LACP on the connected ports, the trunk will be activated automatically.
- A trunk formed with another switch using LACP will automatically be assigned the next available trunk ID.
- If more than eight ports attached to the same target switch have LACP enabled, the additional ports will be placed in standby mode, and will only be enabled if one of the active links fails.
- All ports on both ends of an LACP trunk must be configured for full duplex, and auto-negotiation.
- Trunks dynamically established through LACP will also be shown in the Member List on the Trunk Membership menu (see page 3-115).

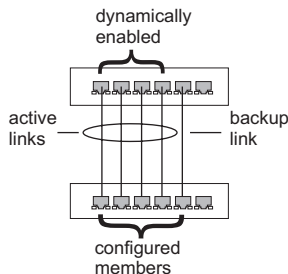

Command Attributes

- **Member List (Current)** – Shows configured trunks (Port).
- **New** – Includes entry fields for creating new trunks.
 - **Port** – Port identifier. (Range: 1-28/52)

Web – Click Port, LACP, Configuration. Select any of the switch ports from the scroll-down port list and click Add. After you have completed adding ports to the member list, click Apply.

LACP Configuration

Member List:

Current:

- Unit1 Port1
- Unit1 Port2
- Unit1 Port3
- Unit1 Port4
- Unit1 Port5
- Unit1 Port6

New:

<<Add

Remove

Port 1

Figure 3-75 LACP Trunk Configuration

3 Configuring the Switch

CLI – The following example enables LACP for ports 1 to 6. Just connect these ports to LACP-enabled trunk ports on another switch to form a trunk.

```
Console(config)#interface ethernet 1/1 4-166
Console(config-if)#lacp 4-182
Console(config-if)#exit
:
Console(config)#interface ethernet 1/6
Console(config-if)#lacp
Console(config-if)#end
Console#show interfaces status port-channel 1 4-173
Information of Trunk 1
Basic information:
  Port type: 100TX
  Mac address: 00-12-CF-12-34-89
Configuration:
  Name:
  Port admin: Up
  Speed-duplex: Auto
  Capabilities: 10half, 10full, 100half, 100full
  Flow control status: Disabled
  Port security: Disabled
  Max MAC count: 0
Current status:
  Created by: Lacp
  Link status: Up
  Port operation status: Up
  Operation speed-duplex: 100full
  Flow control type: None
  Member Ports: Eth1/1, Eth1/2, Eth1/3, Eth1/4, Eth1/5, Eth1/6,
Console#
```

Configuring LACP Parameters

Dynamically Creating a Port Channel –

Ports assigned to a common port channel must meet the following criteria:

- Ports must have the same LACP System Priority.
- Ports must have the same LACP port Admin Key.
- However, if the “port channel” Admin Key is set (page 4-142), then the port Admin Key must be set to the same value for a port to be allowed to join a channel group.

Note – If the port channel admin key (lacp admin key, page 4-185) is not set (through the CLI) when a channel group is formed (i.e., it has a null value of 0), this key is set to the same value as the port admin key used by the interfaces that joined the group (lacp admin key, as described in this section and on page 4-184).

Command Attributes

Set Port Actor – This menu sets the local side of an aggregate link; i.e., the ports on this switch.

- **Port** – Port number. (Range: 1-28/52)
- **System Priority** – LACP system priority is used to determine link aggregation group (LAG) membership, and to identify this device to other switches during LAG negotiations. (Range: 0-65535; Default: 32768)
 - Ports must be configured with the same system priority to join the same LAG.

- System priority is combined with the switch's MAC address to form the LAG identifier. This identifier is used to indicate a specific LAG during LACP negotiations with other systems.
- **Admin Key** – The LACP administration key must be set to the same value for ports that belong to the same LAG. (Range: 0-65535; Default: 1)
- **Port Priority** – If a link goes down, LACP port priority is used to select a backup link. (Range: 0-65535; Default: 32768)

Set Port Partner – This menu sets the remote side of an aggregate link; i.e., the ports on the attached device. The command attributes have the same meaning as those used for the port actor. However, configuring LACP settings for the partner only applies to its administrative state, not its operational state, and will only take effect the next time an aggregate link is established with the partner.

Web – Click Port, LACP, Aggregation Port. Set the System Priority, Admin Key, and Port Priority for the Port Actor. You can optionally configure these settings for the Port Partner. (Be aware that these settings only affect the administrative state of the partner, and will not take effect until the next time an aggregate link is formed with this device.) After you have completed setting the port LACP parameters, click Apply.

Aggregation Port

Set Port Actor:

Port	System Priority (0-65535)	Admin Key (0-65535)	Port Priority (0-65535)
1	3	120	32768
2	3	120	32768
3	3	120	32768
4	3	120	32768
5	3	120	32768
6	3	120	32768
7	3	120	32768
8	3	120	32768
9	3	120	512

Figure 3-76 LACP Port Configuration

3 Configuring the Switch

CLI – The following example configures LACP parameters for ports 1-4. Ports 1-4 are used as active members of the LAG.

```
Console(config)#interface ethernet 1/1 4-166
Console(config-if)#lacp actor system-priority 3 4-183
Console(config-if)#lacp actor admin-key 120 4-184
Console(config-if)#lacp actor port-priority 128 4-186
Console(config-if)#exit
:
Console(config)#interface ethernet 1/4
Console(config-if)#lacp actor system-priority 3
Console(config-if)#lacp actor admin-key 120
Console(config-if)#lacp actor port-priority 512
Console(config-if)#end
Console#show lacp sysid 4-186
Port Channel      System Priority      System MAC Address
-----
          1              3      00-12-CF-31-31-31
          2          32768      00-12-CF-31-31-31
          3          32768      00-12-CF-31-31-31
          4          32768      00-12-CF-31-31-31

Console#show lacp 1 internal 4-186
Port channel : 1
-----
Oper Key : 120
Admin Key : 0
Eth 1/1
-----
LACPDUs Internal:    30 sec
LACP System Priority: 3
LACP Port Priority:  128
Admin Key:           120
Oper Key:            120
Admin State : defaulted, aggregation, long timeout, LACP-activity
Oper State:          distributing, collecting, synchronization,
                    aggregation, long timeout, LACP-activity
:
:
```

Displaying LACP Port Counters

You can display statistics for LACP protocol messages.

Table 3-8 LACP Port Counters

Field	Description
LACPDUs Sent	Number of valid LACPDUs transmitted from this channel group.
LACPDUs Received	Number of valid LACPDUs received on this channel group.
Marker Sent	Number of valid Marker PDUs transmitted from this channel group.
Marker Received	Number of valid Marker PDUs received by this channel group.

Table 3-8 LACP Port Counters (Continued)

Field	Description
Marker Unknown Pkts	Number of frames received that either (1) Carry the Slow Protocols Ethernet Type value, but contain an unknown PDU, or (2) are addressed to the Slow Protocols group MAC Address, but do not carry the Slow Protocols Ethernet Type.
Marker Illegal Pkts	Number of frames that carry the Slow Protocols Ethernet Type value, but contain a badly formed PDU or an illegal value of Protocol Subtype.

Web – Click Port, LACP, Port Counters Information. Select a member port to display the corresponding information.

LACP Port Counters Information

Member Port 1 ▾

Trunk ID : 2

LACPDU's Sent	307	LACPDU's Receive	296
Marker Sent	0	Marker Receive	0
Marker Unknown Pkts	0	Marker Illegal Pkts	0

Figure 3-77 LACP - Port Counters Information

CLI – The following example displays LACP counters.

```

Console#show lacp counters 4-186
Port channel : 1
-----
Eth 1/ 1
-----
LACPDU's Sent:          91
LACPDU's Receive:      43
Marker Sent:            0
Marker Receive:         0
LACPDU's Unknown Pkts: 0
LACPDU's Illegal Pkts: 0
:

```

Displaying LACP Settings and Status for the Local Side

You can display configuration settings and the operational state for the local side of an link aggregation.

Table 3-9 LACP Internal Configuration Information

Field	Description
Oper Key	Current operational value of the key for the aggregation port.
Admin Key	Current administrative value of the key for the aggregation port.
LACPDU Interval	Number of seconds before invalidating received LACPDU information.
LACP System Priority	LACP system priority assigned to this port channel.
LACP Port Priority	LACP port priority assigned to this interface within the channel group.
Admin State, Oper State	Administrative or operational values of the actor's state parameters: <ul style="list-style-type: none"> • Expired – The actor's receive machine is in the expired state; • Defaulted – The actor's receive machine is using defaulted operational partner information, administratively configured for the partner. • Distributing – If false, distribution of outgoing frames on this link is disabled; i.e., distribution is currently disabled and is not expected to be enabled in the absence of administrative changes or changes in received protocol information. • Collecting – Collection of incoming frames on this link is enabled; i.e., collection is currently enabled and is not expected to be disabled in the absence of administrative changes or changes in received protocol information. • Synchronization – The System considers this link to be IN_SYNC; i.e., it has been allocated to the correct Link Aggregation Group, the group has been associated with a compatible Aggregator, and the identity of the Link Aggregation Group is consistent with the System ID and operational Key information transmitted. • Aggregation – The system considers this link to be aggregatable; i.e., a potential candidate for aggregation. • Long timeout – Periodic transmission of LACPDU uses a slow transmission rate. • LACP-Activity – Activity control value with regard to this link. (0: Passive; 1: Active)

Web – Click Port, LACP, Port Internal Information. Select a port channel to display the corresponding information.

LACP Port Internal Information			
Interface Port 3			
Trunk ID : 1			
LACP System Priority	32768	LACP Port Priority	32768
Admin Key	3	Oper Key	3
LACPDUS Interval (secs)	30 seconds		
Admin State : Expired		Oper State : Expired	
Admin State : Defaulted	✓	Oper State : Defaulted	
Admin State : Distributing		Oper State : Distributing	✓
Admin State : Collecting		Oper State : Collecting	✓
Admin State : Synchronization		Oper State : Synchronization	✓
Admin State : Aggregation	✓	Oper State : Aggregation	✓
Admin State : Timeout	Long	Oper State : Timeout	Long
Admin State : LACP-Activity	✓	Oper State : LACP-Activity	✓

Figure 3-78 LACP - Port Internal Information

CLI – The following example displays the LACP configuration settings and operational state for the local side of port channel 1.

```

Console#show lacp 1 internal 4-186
Port channel : 1
-----
Oper Key : 120
Admin Key : 0
Eth 1/1
-----
LACPDUs Internal:    30 sec
LACP System Priority: 3
LACP Port Priority:  128
Admin Key:           120
Oper Key:            120
Admin State : defaulted, aggregation, long timeout, LACP-activity
Oper State:         distributing, collecting, synchronization,
                    aggregation, long timeout, LACP-activity
:
:
:

```

3 Configuring the Switch

Displaying LACP Settings and Status for the Remote Side

You can display configuration settings and the operational state for the remote side of an link aggregation.

Table 3-10 LACP Neighbor Configuration Information

Field	Description
Partner Admin System ID	LAG partner's system ID assigned by the user.
Partner Oper System ID	LAG partner's system ID assigned by the LACP protocol.
Partner Admin Port Number	Current administrative value of the port number for the protocol Partner.
Partner Oper Port Number	Operational port number assigned to this aggregation port by the port's protocol partner.
Port Admin Priority	Current administrative value of the port priority for the protocol partner.
Port Oper Priority	Priority value assigned to this aggregation port by the partner.
Admin Key	Current administrative value of the Key for the protocol partner.
Oper Key	Current operational value of the Key for the protocol partner.
Admin State	Administrative values of the partner's state parameters. (See preceding table.)
Oper State	Operational values of the partner's state parameters. (See preceding table.)

Web – Click Port, LACP, Port Neighbors Information. Select a port channel to display the corresponding information.

LACP Port Neighbors Information

Interface Port 2

Trunk ID : 1

Partner Admin System ID	32768, 00-00-00-00-00-00	Partner Oper System ID	32768, 00-12-CF-DF-9E-C0
Partner Admin Port Number	58	Partner Oper Port Number	2
Port Admin Priority	32768	Port Oper Priority	32768
Admin Key	0	Oper Key	4
Admin State : Expired		Oper State : Expired	
Admin State : Defaulted	✓	Oper State : Defaulted	
Admin State : Distributing	✓	Oper State : Distributing	✓
Admin State : Collecting	✓	Oper State : Collecting	✓
Admin State : Synchronization	✓	Oper State : Synchronization	✓
Admin State : Aggregation		Oper State : Aggregation	✓
Admin State : Timeout	Long	Oper State : Timeout	Long
Admin State : LACP-Activity		Oper State : LACP-Activity	✓

Figure 3-79 LACP - Port Neighbors Information

CLI – The following example displays the LACP configuration settings and operational state for the remote side of port channel 1.

```
Console#show lacp 1 neighbors 4-186
Port channel 1 neighbors
-----
Eth 1/1
-----
Partner Admin System ID: 32768, 00-00-00-00-00-00
Partner Oper System ID: 3, 00-12-CF-CE-2A-20
Partner Admin Port Number: 5
Partner Oper Port Number: 3
Port Admin Priority: 32768
Port Oper Priority: 128
Admin Key: 0
Oper Key: 120
Admin State: defaulted, distributing, collecting,
synchronization, long timeout,
Oper State: distributing, collecting, synchronization,
aggregation, long timeout, LACP-activity
:
```

Setting Broadcast Storm Thresholds

Broadcast storms may occur when a device on your network is malfunctioning, or if application programs are not well designed or properly configured. If there is too much broadcast traffic on your network, performance can be severely degraded or everything can come to complete halt.

You can protect your network from broadcast storms by setting a threshold for broadcast traffic. Any broadcast packets exceeding the specified threshold will then be dropped.

Command Usage

- Broadcast Storm Control is enabled by default.
- Broadcast control does not effect IP multicast traffic.

Command Attributes

- **Port** - Port number.
- **Type** – Indicates the port type. (100BASE-TX, 1000BASE-T, or SFP)
- **Protect Status** – Shows whether or not broadcast storm control has been enabled. (Default: Enabled)
- **Threshold** – Threshold as percentage of port bandwidth. (Range: 64-100000 kilobits per second for Fast Ethernet ports; 64-1000000 kilobits per second for Gigabit ports)
- **Trunk** – Shows if a port is a trunk member.

3 Configuring the Switch

Web – Click Port, Port/Trunk Broadcast Control. Set the threshold, mark the Enabled field for the desired interface and click Apply.

Port Broadcast Control

For a 100 Mbps port, the threshold range is 64 to 100000 kilobits per second.
For a 1 Gbps port, the threshold range is 64 to 1000000 kilobits per second.

Port	Type	Protect Status	Threshold (64-1000000)	Trunk
1	100Base-TX	<input checked="" type="checkbox"/> Enabled	64 (kbits/sec)	
2	100Base-TX	<input checked="" type="checkbox"/> Enabled	64 (kbits/sec)	
3	100Base-TX	<input checked="" type="checkbox"/> Enabled	64 (kbits/sec)	
4	100Base-TX	<input checked="" type="checkbox"/> Enabled	64 (kbits/sec)	
5	100Base-TX	<input checked="" type="checkbox"/> Enabled	64 (kbits/sec)	
6	100Base-TX	<input checked="" type="checkbox"/> Enabled	64 (kbits/sec)	
7	100Base-TX	<input checked="" type="checkbox"/> Enabled	64 (kbits/sec)	

Figure 3-80 Port Broadcast Control

CLI – Specify any interface, and then enter the threshold. The following disables broadcast storm control for port 1, and then sets broadcast suppression at 500 kilobits per second for port 2.

```
Console(config)#interface ethernet 1/1 4-166
Console(config-if)#no switchport broadcast 4-172
Console(config-if)#exit
Console(config)#interface ethernet 1/2
Console(config-if)#switchport broadcast packet-rate 500 4-172
Console(config-if)#end
Console#show interfaces switchport ethernet 1/2 4-175
Information of Eth 1/2
Broadcast threshold: Enabled, 500 Kbits/second
LACP status: Disabled
Ingress Rate Limit: Disabled, 100000 Kbits per second
Egress Rate Limit: Disabled, 100000 Kbits per second
VLAN membership mode: Hybrid
Ingress rule: Enabled
Acceptable frame type: All frames
Native VLAN: 1
Priority for untagged traffic: 0
GVRP status: Disabled
Allowed VLAN: 1(u),
Forbidden VLAN:
Private-VLAN mode: NONE
Private-VLAN host-association: NONE
Private-VLAN mapping: NONE
Console#
```

Configuring Port Mirroring

You can mirror traffic from any source port to a target port for real-time analysis. You can then attach a logic analyzer or RMON probe to the target port and study the traffic crossing the source port in a completely unobtrusive manner.

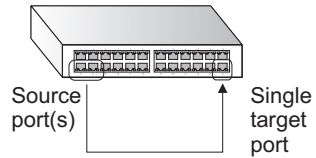

Command Usage

- Monitor port speed should match or exceed source port speed, otherwise traffic may be dropped from the monitor port.
- All mirror sessions must share the same destination port.
- When mirroring port traffic, the target port must be included in the same VLAN as the source port.

Command Attributes

- **Mirror Sessions** – Displays a list of current mirror sessions.
- **Source Port** – The port whose traffic will be monitored. (Range: 1-28/52)
- **Type** – Allows you to select which traffic to mirror to the target port, Rx (receive), or Tx (transmit). (Default: Rx)
- **Target Port** – The port that will mirror the traffic on the source port. (Range: 1-28/52)

Web – Click Port, Mirror Port Configuration. Specify the source port, the traffic type to be mirrored, and the monitor port, then click Add.

Mirror Port Configuration

Mirror Sessions:

Source: 1/10 Both Destination: 1/13

New:

Source Port	1
Type	Rx
Target Port	1

<<Add
Remove

Figure 3-81 Mirror Port Configuration

CLI – Use the interface command to select the monitor port, then use the port monitor command to specify the source port and traffic type.

```

Console(config)#interface ethernet 1/10          4-166
Console(config-if)#port monitor ethernet 1/13 tx 4-177
Console(config-if)#

```

Configuring Rate Limits

This function allows the network manager to control the maximum rate for traffic received on a port or transmitted from a port. Rate limiting is configured on ports at the edge of a network to limit traffic coming in and out of the network. Packets that exceed the acceptable amount of traffic are dropped.

Rate limiting can be applied to individual ports or trunks. When an interface is configured with this feature, the traffic rate will be monitored by the hardware to verify conformity. Non-conforming traffic is dropped, conforming traffic is forwarded without any changes.

Rate Limit Configuration

Use the rate limit configuration pages to apply rate limiting.

Command Usage

- Input and output rate limits can be enabled or disabled for individual interfaces.

Command Attributes

- **Port/Trunk** – Displays the port/trunk number.
- **Input/Output Rate Limit Status** – Enables or disables the rate limit. (Default: Enabled)
- **Input/Output Rate Limit** – Sets the rate limit level.

Web – Click Port, Rate Limit, Input/Output Port/Trunk Configuration. Enable the Rate Limit Status for the required interfaces, set the Rate Limit Level, and click Apply.

Port	Input Rate Limit Status	Input Rate Limit (Kbps)	Trunk
1	<input checked="" type="checkbox"/> Enabled	100000	
2	<input checked="" type="checkbox"/> Enabled	100000	
3	<input checked="" type="checkbox"/> Enabled	100000	
4	<input checked="" type="checkbox"/> Enabled	100000	
5	<input checked="" type="checkbox"/> Enabled	100000	
6	<input checked="" type="checkbox"/> Enabled	100000	

Figure 3-82 Input Rate Limit Port Configuration

CLI - This example sets the rate limit level for input traffic passing through port 3.

```
Console(config)#interface ethernet 1/3          4-166
Console(config-if)#rate-limit input 500        4-179
Console(config-if)#
```

Showing Port Statistics

You can display standard statistics on network traffic from the Interfaces Group and Ethernet-like MIBs, as well as a detailed breakdown of traffic based on the RMON MIB. Interfaces and Ethernet-like statistics display errors on the traffic passing through each port. This information can be used to identify potential problems with the switch (such as a faulty port or unusually heavy loading). RMON statistics provide access to a broad range of statistics, including a total count of different frame types and sizes passing through each port. All values displayed have been accumulated since the last system reboot, and are shown as counts per second. Statistics are refreshed every 60 seconds by default.

Note: RMON groups 2, 3 and 9 can only be accessed using SNMP management software such as HP OpenView.

Table 3-11 Port Statistics

Parameter	Description
<i>Interface Statistics</i>	
Received Octets	The total number of octets received on the interface, including framing characters.
Received Unicast Packets	The number of subnetwork-unicast packets delivered to a higher-layer protocol.
Received Multicast Packets	The number of packets, delivered by this sub-layer to a higher (sub-)layer, which were addressed to a multicast address at this sub-layer.
Received Broadcast Packets	The number of packets, delivered by this sub-layer to a higher (sub-)layer, which were addressed to a broadcast address at this sub-layer.
Received Discarded Packets	The number of inbound packets which were chosen to be discarded even though no errors had been detected to prevent their being deliverable to a higher-layer protocol. One possible reason for discarding such a packet could be to free up buffer space.
Received Unknown Packets	The number of packets received via the interface which were discarded because of an unknown or unsupported protocol.
Received Errors	The number of inbound packets that contained errors preventing them from being deliverable to a higher-layer protocol.
Transmit Octets	The total number of octets transmitted out of the interface, including framing characters.
Transmit Unicast Packets	The total number of packets that higher-level protocols requested be transmitted to a subnetwork-unicast address, including those that were discarded or not sent.
Transmit Multicast Packets	The total number of packets that higher-level protocols requested be transmitted, and which were addressed to a multicast address at this sub-layer, including those that were discarded or not sent.
Transmit Broadcast Packets	The total number of packets that higher-level protocols requested be transmitted, and which were addressed to a broadcast address at this sub-layer, including those that were discarded or not sent.

Table 3-11 Port Statistics (Continued)

Parameter	Description
Transmit Discarded Packets	The number of outbound packets which were chosen to be discarded even though no errors had been detected to prevent their being transmitted. One possible reason for discarding such a packet could be to free up buffer space.
Transmit Errors	The number of outbound packets that could not be transmitted because of errors.
<i>Etherlike Statistics</i>	
Alignment Errors	The number of alignment errors (missynchronized data packets).
Late Collisions	The number of times that a collision is detected later than 512 bit-times into the transmission of a packet.
FCS Errors	A count of frames received on a particular interface that are an integral number of octets in length but do not pass the FCS check. This count does not include frames received with frame-too-long or frame-too-short error.
Excessive Collisions	A count of frames for which transmission on a particular interface fails due to excessive collisions. This counter does not increment when the interface is operating in full-duplex mode.
Single Collision Frames	The number of successfully transmitted frames for which transmission is inhibited by exactly one collision.
Internal MAC Transmit Errors	A count of frames for which transmission on a particular interface fails due to an internal MAC sublayer transmit error.
Multiple Collision Frames	A count of successfully transmitted frames for which transmission is inhibited by more than one collision.
Carrier Sense Errors	The number of times that the carrier sense condition was lost or never asserted when attempting to transmit a frame.
SQE Test Errors	A count of times that the SQE TEST ERROR message is generated by the PLS sublayer for a particular interface.
Frames Too Long	A count of frames received on a particular interface that exceed the maximum permitted frame size.
Deferred Transmissions	A count of frames for which the first transmission attempt on a particular interface is delayed because the medium was busy.
Internal MAC Receive Errors	A count of frames for which reception on a particular interface fails due to an internal MAC sublayer receive error.
<i>RMON Statistics</i>	
Drop Events	The total number of events in which packets were dropped due to lack of resources.
Jabbers	The total number of frames received that were longer than 1518 octets (excluding framing bits, but including FCS octets), and had either an FCS or alignment error.
Received Bytes	Total number of bytes of data received on the network. This statistic can be used as a reasonable indication of Ethernet utilization.
Collisions	The best estimate of the total number of collisions on this Ethernet segment.

Table 3-11 Port Statistics (Continued)

Parameter	Description
Received Frames	The total number of frames (bad, broadcast and multicast) received.
Broadcast Frames	The total number of good frames received that were directed to the broadcast address. Note that this does not include multicast packets.
Multicast Frames	The total number of good frames received that were directed to this multicast address.
CRC/Alignment Errors	The number of CRC/alignment errors (FCS or alignment errors).
Undersize Frames	The total number of frames received that were less than 64 octets long (excluding framing bits, but including FCS octets) and were otherwise well formed.
Oversize Frames	The total number of frames received that were longer than 1518 octets (excluding framing bits, but including FCS octets) and were otherwise well formed.
Fragments	The total number of frames received that were less than 64 octets in length (excluding framing bits, but including FCS octets) and had either an FCS or alignment error.
64 Bytes Frames	The total number of frames (including bad packets) received and transmitted that were 64 octets in length (excluding framing bits but including FCS octets).
65-127 Byte Frames 128-255 Byte Frames 256-511 Byte Frames 512-1023 Byte Frames 1024-1518 Byte Frames 1519-1536 Byte Frames	The total number of frames (including bad packets) received and transmitted where the number of octets fall within the specified range (excluding framing bits but including FCS octets).

3 Configuring the Switch

Web – Click Port, Port Statistics. Select the required interface, and click Query. You can also use the Refresh button at the bottom of the page to update the screen.

Port Statistics

Interface Port 1 Trunk

Query

Interface Statistics:

Received Octets	15020	Received Unicast Packets	0
Received Multicast Packets	177	Received Broadcast Packets	0
Received Discarded Packets	0	Received Unknown Packets	0
Received Errors	0	Transmit Octets	168087
Transmit Unicast Packets	0	Transmit Multicast Packets	2420
Transmit Broadcast Packets	47	Transmit Discarded Packets	0
Transmit Errors	0		

Etherlike Statistics:

Alignment Errors	0	Late Collisions	0
FCS Errors	0	Excessive Collisions	0
Single Collision Frames	0	Internal MAC Transmit Errors	0
Multiple Collision Frames	0	Carrier Sense Errors	0
SQE Test Errors	0	Frames Too Long	0
Deferred Transmissions	0	Internal MAC Receive Errors	0

RMON Statistics:

Drop Events	0	Jabbers	0
Received Bytes	188155	Collisions	0
Received Frames	0	64 Bytes Frames	2249
Broadcast Frames	47	65-127 Bytes Frames	459
Multicast Frames	2672	128-255 Bytes Frames	11
CRC/Alignment Errors	0	256-511 Bytes Frames	0
Undersize Frames	0	512-1023 Bytes Frames	0
Oversize Frames	0	1024-1518 Bytes Frames	0
Fragments	0		

Refresh

Figure 3-83 Port Statistics

CLI – This example shows statistics for port 13.

```
Console#show interfaces counters ethernet 1/13 4-174
Ethernet 1/13
  Iftable stats:
    Octets input: 868453, Octets output: 3492122
    Unicast input: 7315, Unicast output: 6658
    Discard input: 0, Discard output: 0
    Error input: 0, Error output: 0
    Unknown protos input: 0, QLen output: 0
  Extended iftable stats:
    Multi-cast input: 0, Multi-cast output: 17027
    Broadcast input: 231, Broadcast output: 7
  Ether-like stats:
    Alignment errors: 0, FCS errors: 0
    Single Collision frames: 0, Multiple collision frames: 0
    SQE Test errors: 0, Deferred transmissions: 0
    Late collisions: 0, Excessive collisions: 0
    Internal mac transmit errors: 0, Internal mac receive errors: 0
    Frame too longs: 0, Carrier sense errors: 0
    Symbol errors: 0
  RMON stats:
    Drop events: 0, Octets: 4422579, Packets: 31552
    Broadcast pkts: 238, Multi-cast pkts: 17033
    Undersize pkts: 0, Oversize pkts: 0
    Fragments: 0, Jabbers: 0
    CRC align errors: 0, Collisions: 0
    Packet size <= 64 octets: 25568, Packet size 65 to 127 octets: 1616
    Packet size 128 to 255 octets: 1249, Packet size 256 to 511 octets: 1449
    Packet size 512 to 1023 octets: 802, Packet size 1024 to 1518 octets: 871
Console#
```

Address Table Settings

Switches store the addresses for all known devices. This information is used to pass traffic directly between the inbound and outbound ports. All the addresses learned by monitoring traffic are stored in the dynamic address table. You can also manually configure static addresses that are bound to a specific port.

Setting Static Addresses

A static address can be assigned to a specific interface on this switch. Static addresses are bound to the assigned interface and will not be moved. When a static address is seen on another interface, the address will be ignored and will not be written to the address table.

Command Attributes

- **Static Address Counts**⁸ – The number of manually configured addresses.
- **Current Static Address Table** – Lists all the static addresses.
- **Interface** – Port or trunk associated with the device assigned a static address.
- **MAC Address** – Physical address of a device mapped to this interface.
- **VLAN** – ID of configured VLAN (1-4093).

8. Web only.

3 Configuring the Switch

Web – Click Address Table, Static Addresses. Specify the interface, the MAC address and VLAN, then click Add Static Address.

The screenshot shows a web-based configuration page titled "Static Addresses". It contains a form with the following fields and controls:

- Static Address Counts:** A text input field containing the number "1".
- Current Static Address Table:** A table with one row containing the text "00-E0-29-94-34-DE, VLAN 1, Unit 1, Port 1, Permanent".
- Interface:** A radio button labeled "Port" is selected, followed by a dropdown menu showing "1". To the right, a radio button labeled "Trunk" is unselected, followed by a dropdown menu.
- MAC Address:** A text input field with a placeholder "(XX-XX-XX-XX-XX-XX)".
- VLAN:** A dropdown menu showing "1".
- Buttons:** Two buttons at the bottom: "Add Static Address" and "Remove Static Address".

Figure 3-84 Configuring a Static Address Table

CLI – This example adds an address to the static address table, but sets it to be deleted when the switch is reset.

```
Console(config)#mac-address-table static 00-12-cf-94-34-de
interface ethernet 1/1 vlan 1 delete-on-reset
Console(config)#
```

4-190

Displaying the Address Table

The Dynamic Address Table contains the MAC addresses learned by monitoring the source address for traffic entering the switch. When the destination address for inbound traffic is found in the database, the packets intended for that address are forwarded directly to the associated port. Otherwise, the traffic is flooded to all ports.

Command Attributes

- **Interface** – Indicates a port or trunk.
- **MAC Address** – Physical address associated with this interface.
- **VLAN** – ID of configured VLAN (1-4093).
- **Address Table Sort Key** – You can sort the information displayed based on MAC address, VLAN or interface (port or trunk).
- **Dynamic Address Counts** – The number of addresses dynamically learned.
- **Current Dynamic Address Table** – Lists all the dynamic addresses.

Web – Click Address Table, Dynamic Addresses. Specify the search type (i.e., mark the Interface, MAC Address, or VLAN checkbox), select the method of sorting the displayed addresses, and then click Query.

Dynamic Addresses

Query by:
 Interface Port 1 ▾ Trunk ▾
 MAC Address
 VLAN 1 ▾
 Address Table Sort Key | Address ▾

Dynamic Address Table

Dynamic Address Counts	
Current Dynamic Address Table	00-01-80-4B-82-93, VLAN 1, Unit 1, Port 1, Dynamic

Figure 3-85 Configuring a Dynamic Address Table

CLI – This example also displays the address table entries for port 1.

```

Console#show mac-address-table interface ethernet 1/1 4-191
Interface Mac Address          Vlan Type
-----
  Eth 1/ 1 00-12-CF-48-82-93    1 Delete-on-reset
  Eth 1/ 1 00-12-CF-94-34-DE    2 Learned
Console#
```

Changing the Aging Time

You can set the aging time for entries in the dynamic address table.

Command Attributes

- **Aging Status** – Enables/disables the function.
- **Aging Time** – The time after which a learned entry is discarded.
(Range: 10-630 seconds; Default: 300 seconds)

Web – Click Address Table, Address Aging. Specify the new aging time, click Apply.

Address Aging

Aging Status	<input checked="" type="checkbox"/> Enabled
Aging Time (10-630):	<input type="text" value="300"/> seconds

Figure 3-86 Setting the Address Aging Time

CLI – This example sets the aging time to 300 seconds.

```
Console(config)#mac-address-table aging-time 300 4-192
Console(config)#
```

Spanning Tree Algorithm Configuration

The Spanning Tree Algorithm (STA) can be used to detect and disable network loops, and to provide backup links between switches, bridges or routers. This allows the switch to interact with other bridging devices (that is, an STA-compliant switch, bridge or router) in your network to ensure that only one route exists between any two stations on the network, and provide backup links which automatically take over when a primary link goes down.

The spanning tree algorithms supported by this switch include these versions:

- STP – Spanning Tree Protocol (IEEE 802.1D)
- RSTP – Rapid Spanning Tree Protocol (IEEE 802.1w)
- MSTP – Multiple Spanning Tree Protocol (IEEE 802.1s)

STP – STP uses a distributed algorithm to select a bridging device (STP-compliant switch, bridge or router) that serves as the root of the spanning tree network. It selects a root port on each bridging device (except for the root device) which incurs the lowest path cost when forwarding a packet from that device to the root device. Then it selects a designated bridging device from each LAN which incurs the lowest path cost when forwarding a packet from that LAN to the root device. All ports connected to designated bridging devices are assigned as designated ports. After determining the lowest cost spanning tree, it enables all root ports and designated ports, and disables all other ports. Network packets are therefore only forwarded between root ports and designated ports, eliminating any possible network loops.

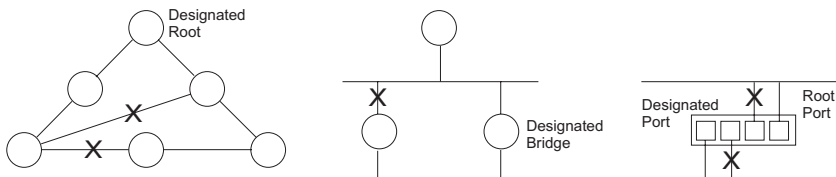

Once a stable network topology has been established, all bridges listen for Hello BPDUs (Bridge Protocol Data Units) transmitted from the Root Bridge. If a bridge does not get a Hello BPDU after a predefined interval (Maximum Age), the bridge assumes that the link to the Root Bridge is down. This bridge will then initiate negotiations with other bridges to reconfigure the network to reestablish a valid network topology.

RSTP – RSTP is designed as a general replacement for the slower, legacy STP. RSTP is also incorporated into MSTP. RSTP achieves much faster reconfiguration (i.e., around 1 to 3 seconds, compared to 30 seconds or more for STP) by reducing the number of state changes before active ports start learning, predefining an alternate route that can be used when a node or port fails, and retaining the forwarding database for ports insensitive to changes in the tree structure when reconfiguration occurs.

MSTP – When using STP or RSTP, it may be difficult to maintain a stable path between all VLAN members. Frequent changes in the tree structure can easily

3 Configuring the Switch

isolate some of the group members. MSTP (which is based on RSTP for fast convergence) is designed to support independent spanning trees based on VLAN groups. Using multiple spanning trees can provide multiple forwarding paths and enable load balancing. One or more VLANs can be grouped into a Multiple Spanning Tree Instance (MSTI). MSTP builds a separate Multiple Spanning Tree (MST) for each instance to maintain connectivity among each of the assigned VLAN groups. MSTP then builds an Internal Spanning Tree (IST) for the Region containing all commonly configured MSTP bridges.

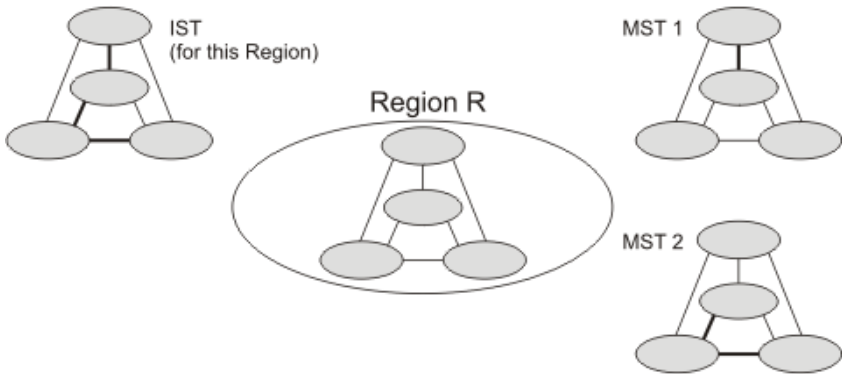

An MST Region consists of a group of interconnected bridges that have the same MST Configuration Identifiers (including the Region Name, Revision Level and Configuration Digest – see “Configuring Multiple Spanning Trees” on page 11-18). An MST Region may contain multiple MSTP Instances. An Internal Spanning Tree (IST) is used to connect all the MSTP switches within an MST region. A Common Spanning Tree (CST) interconnects all adjacent MST Regions, and acts as a virtual bridge node for communications with STP or RSTP nodes in the global network.

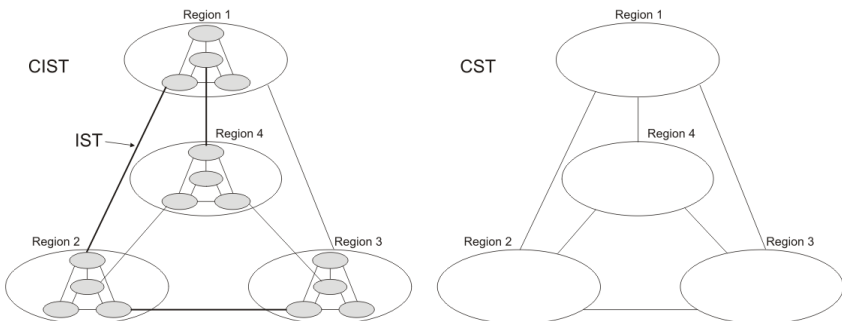

MSTP connects all bridges and LAN segments with a single Common and Internal Spanning Tree (CIST). The CIST is formed as a result of the running spanning tree algorithm between switches that support the STP, RSTP, MSTP protocols.

Configuring Port and Trunk Loopback Detection

When Port Loopback Detection is enabled and a port receives its own BPDU, the detection agent drops the loopback BPDU, sends an SNMP trap and places the port in discarding mode. This loopback state can be released manually or automatically. If the port is configured for automatic loopback release, then the port will only be returned to the forwarding state if one of the following conditions is satisfied:

- The port receives any other BPDU except for its own, or;
- The port's link status changes to link down and then link up again, or;
- The port ceases to receive its own BPDUs in a forward delay interval.

- Notes:**
1. If Port Loopback Detection is not enabled and a port receives its own BPDU, then the port will drop the loopback BPDU according to IEEE Standard 802.1W-2001 9.3.4 (Note 1).
 2. Port Loopback Detection will not be active if Spanning Tree is disabled on the switch.
 3. When configured for manual release mode, then a link down / up event will not release the port from the discarding state.

Field Attributes

- **Port** – Indicates the interface to be configured.
- **Status** – Enables Loopback Detection on this interface. (Default: Enabled)
- **Trap** – Enables SNMP trap notification for loopback events on this port. (Default: Disabled)
- **Release Mode** – Configures the port for automatic or manual loopback release mode. (Default: Auto)
- **Release** – Allows a port to be manually released from discard mode. This is only available if the port is configured for manual release mode.
- **Trunk** – Indicates if this port is a trunk member.

Web – Click Spanning Tree, Port Loopback Detection or Trunk Loopback Detection. Modify the required attributes, then click Apply.

Port Loopback Detection					
Port	Status	Trap	Release Mode	Release	Trunk
1	<input type="checkbox"/> Enabled	<input type="checkbox"/> Enabled	Auto	Release	
2	<input checked="" type="checkbox"/> Enabled	<input checked="" type="checkbox"/> Enabled	Auto	Release	
3	<input checked="" type="checkbox"/> Enabled	<input checked="" type="checkbox"/> Enabled	Auto	Release	
4	<input checked="" type="checkbox"/> Enabled	<input checked="" type="checkbox"/> Enabled	Manual	Release	
5	<input checked="" type="checkbox"/> Enabled	<input checked="" type="checkbox"/> Enabled	Manual	Release	
6	<input checked="" type="checkbox"/> Enabled	<input type="checkbox"/> Enabled	Auto	Release	
7	<input checked="" type="checkbox"/> Enabled	<input type="checkbox"/> Enabled	Auto	Release	
8	<input checked="" type="checkbox"/> Enabled	<input type="checkbox"/> Enabled	Auto	Release	
9	<input checked="" type="checkbox"/> Enabled	<input type="checkbox"/> Enabled	Auto	Release	

Figure 3-87 Configuring Port Loopback Detection

3 Configuring the Switch

CLI – This command enables loopback detection for port 1/5, configures automatic release-mode and enables SNMP trap notification for detected loopback BPDU's.

```
Console(config)#interface ethernet 1/5 4-166
Console(config-if)#spanning-tree loopback-detection 4-231
Console(config-if)#spanning-tree loopback-detection release-mode auto4-232
Console(config-if)#spanning-tree loopback-detection trap 4-233
```

Displaying Global Settings

You can display a summary of the current bridge STA information that applies to the entire switch using the STA Information screen.

Field Attributes

- **Spanning Tree State** – Shows if the switch is enabled to participate in an STA-compliant network.
- **Bridge ID** – A unique identifier for this bridge, consisting of the bridge priority and MAC address (where the address is taken from the switch system).
- **Max Age** – The maximum time (in seconds) a device can wait without receiving a configuration message before attempting to reconfigure. All device ports (except for designated ports) should receive configuration messages at regular intervals. Any port that ages out STA information (provided in the last configuration message) becomes the designated port for the attached LAN. If it is a root port, a new root port is selected from among the device ports attached to the network. (References to “ports” in this section mean “interfaces,” which includes both ports and trunks.)
- **Hello Time** – Interval (in seconds) at which the root device transmits a configuration message.
- **Forward Delay** – The maximum time (in seconds) the root device will wait before changing states (i.e., discarding to learning to forwarding). This delay is required because every device must receive information about topology changes before it starts to forward frames. In addition, each port needs time to listen for conflicting information that would make it return to a discarding state; otherwise, temporary data loops might result.
- **Designated Root** – The priority and MAC address of the device in the Spanning Tree that this switch has accepted as the root device.
 - **Root Port** – The number of the port on this switch that is closest to the root. This switch communicates with the root device through this port. If there is no root port, then this switch has been accepted as the root device of the Spanning Tree network.
 - **Root Path Cost** – The path cost from the root port on this switch to the root device.
- **Configuration Changes** – The number of times the Spanning Tree has been reconfigured.
- **Last Topology Change** – Time since the Spanning Tree was last reconfigured.

These additional parameters are only displayed for the CLI:

- **Spanning tree mode** – Specifies the type of spanning tree used on this switch:
 - **STP**: Spanning Tree Protocol (IEEE 802.1D)
 - **RSTP**: Rapid Spanning Tree (IEEE 802.1w)
 - **MSTP**: Multiple Spanning Tree (IEEE 802.1s)
- **Priority** – Bridge priority is used in selecting the root device, root port, and designated port. The device with the highest priority becomes the STA root device. However, if all devices have the same priority, the device with the lowest MAC address will then become the root device.
- **Root Hello Time** – Interval (in seconds) at which this device transmits a configuration message.
- **Root Maximum Age** – The maximum time (in seconds) this device can wait without receiving a configuration message before attempting to reconfigure. All device ports (except for designated ports) should receive configuration messages at regular intervals. If the root port ages out STA information (provided in the last configuration message), a new root port is selected from among the device ports attached to the network. (References to “ports” in this section means “interfaces,” which includes both ports and trunks.)
- **Root Forward Delay** – The maximum time (in seconds) this device will wait before changing states (i.e., discarding to learning to forwarding). This delay is required because every device must receive information about topology changes before it starts to forward frames. In addition, each port needs time to listen for conflicting information that would make it return to a discarding state; otherwise, temporary data loops might result.
- **Transmission limit** – The minimum interval between the transmission of consecutive RSTP/MSTP BPDUs.
- **Path Cost Method** – The path cost is used to determine the best path between devices. The path cost method is used to determine the range of values that can be assigned to each interface.

Web – Click Spanning Tree, STA, Information.

STA Information

Spanning Tree:

Spanning Tree State	Enabled	Designated Root	32768.0012CF0B0D00
Bridge ID	32768.0012CF0B0D00	Root Port	0
Max Age	20	Root Path Cost	0
Hello Time	2	Configuration Changes	1
Forward Delay	15	Last Topology Change	0 d 0 h 16 min 23 s

Figure 3-88 Displaying Spanning Tree Information

3 Configuring the Switch

CLI – This command displays global STA settings, followed by settings for each port.

```
Console#show spanning-tree 4-235
Spanning-tree information
-----
Spanning tree mode:                RSTP
Spanning tree enabled/disabled:    enabled
Priority:                           32768
Bridge Hello Time (sec.):           2
Bridge Max Age (sec.):              20
Bridge Forward Delay (sec.):        15
Root Hello Time (sec.):             2
Root Max Age (sec.):                20
Root Forward Delay (sec.):          15
Designated Root:                   32768.0012CF0B0D00
Current root port:                  0
Current root cost:                  0
Number of topology changes:         1
Last topology changes time (sec.): 2262
Transmission limit:                 3
Path Cost Method:                   long
:
:
```

Note: The current root port and current root cost display as zero when this device is not connected to the network.

Configuring Global Settings

Global settings apply to the entire switch.

Command Usage

- Spanning Tree Protocol⁹

Uses RSTP for the internal state machine, but sends only 802.1D BPDUs. This creates one spanning tree instance for the entire network. If multiple VLANs are implemented on a network, the path between specific VLAN members may be inadvertently disabled to prevent network loops, thus isolating group members. When operating multiple VLANs, we recommend selecting the MSTP option.

- Rapid Spanning Tree Protocol⁹

RSTP supports connections to either STP or RSTP nodes by monitoring the incoming protocol messages and dynamically adjusting the type of protocol messages the RSTP node transmits, as described below:

- STP Mode – If the switch receives an 802.1D BPDU (i.e., STP BPDU) after a port's migration delay timer expires, the switch assumes it is connected to an 802.1D bridge and starts using only 802.1D BPDUs.
- RSTP Mode – If RSTP is using 802.1D BPDUs on a port and receives an RSTP BPDU after the migration delay expires, RSTP restarts the migration delay timer and begins using RSTP BPDUs on that port.

- Multiple Spanning Tree Protocol

9. STP and RSTP BPDUs are transmitted as untagged frames, and will cross any VLAN boundaries.

- To allow multiple spanning trees to operate over the network, you must configure a related set of bridges with the same MSTP configuration, allowing them to participate in a specific set of spanning tree instances.
- A spanning tree instance can exist only on bridges that have compatible VLAN instance assignments.
- Be careful when switching between spanning tree modes. Changing modes stops all spanning-tree instances for the previous mode and restarts the system in the new mode, temporarily disrupting user traffic.

Command Attributes

Basic Configuration of Global Settings

- **Spanning Tree State** – Enables/disables STA on this switch. (Default: Enabled)
- **Spanning Tree Type** – Specifies the type of spanning tree used on this switch:
 - **STP**: Spanning Tree Protocol (IEEE 802.1D); i.e., when this option is selected, the switch will use RSTP set to STP forced compatibility mode).
 - **RSTP**: Rapid Spanning Tree (IEEE 802.1w); RSTP is the default.
 - **MSTP**: Multiple Spanning Tree (IEEE 802.1s);
- **Priority** – Bridge priority is used in selecting the root device, root port, and designated port. The device with the highest priority becomes the STA root device. However, if all devices have the same priority, the device with the lowest MAC address will then become the root device. (Note that lower numeric values indicate higher priority.)
 - Default: 32768
 - Range: 0-61440, in steps of 4096
 - Options: 0, 4096, 8192, 12288, 16384, 20480, 24576, 28672, 32768, 36864, 40960, 45056, 49152, 53248, 57344, 61440

Root Device Configuration

- **Hello Time** – Interval (in seconds) at which the root device transmits a configuration message.
 - Default: 2
 - Minimum: 1
 - Maximum: The lower of 10 or $[(\text{Max. Message Age} / 2) - 1]$
- **Maximum Age** – The maximum time (in seconds) a device can wait without receiving a configuration message before attempting to reconfigure. All device ports (except for designated ports) should receive configuration messages at regular intervals. Any port that ages out STA information (provided in the last configuration message) becomes the designated port for the attached LAN. If it is a root port, a new root port is selected from among the device ports attached to the network. (References to “ports” in this section mean “interfaces,” which includes both ports and trunks.)
 - Default: 20
 - Minimum: The higher of 6 or $[2 \times (\text{Hello Time} + 1)]$.
 - Maximum: The lower of 40 or $[2 \times (\text{Forward Delay} - 1)]$

3 Configuring the Switch

- **Forward Delay** – The maximum time (in seconds) this device will wait before changing states (i.e., discarding to learning to forwarding). This delay is required because every device must receive information about topology changes before it starts to forward frames. In addition, each port needs time to listen for conflicting information that would make it return to a discarding state; otherwise, temporary data loops might result.
 - Default: 15
 - Minimum: The higher of 4 or $[(\text{Max. Message Age} / 2) + 1]$
 - Maximum: 30

Configuration Settings for RSTP

The following attributes apply to both RSTP and MSTP:

- **Path Cost Method** – The path cost is used to determine the best path between devices. The path cost method is used to determine the range of values that can be assigned to each interface.
 - Long: Specifies 32-bit based values that range from 1-200,000,000. (This is the default.)
 - Short: Specifies 16-bit based values that range from 1-65535.
- **Transmission Limit** – The maximum transmission rate for BPDUs is specified by setting the minimum interval between the transmission of consecutive protocol messages. (Range: 1-10; Default: 3)

Configuration Settings for MSTP

- **Max Instance Numbers** – The maximum number of MSTP instances to which this switch can be assigned.
- **Region Revision** – The revision for this MSTI. (Range: 0-65535; Default: 0)
- **Region Name** – The name for this MSTI. (Maximum length: 32 characters)
- **Maximum Hop Count** – The maximum number of hops allowed in the MST region before a BPDU is discarded. (Range: 1-40; Default: 20)

Note: The MST name and revision number are both required to uniquely identify an MST region.

Web – Click Spanning Tree, STA, Configuration. Modify the required attributes, and click Apply.

STA Configuration

Switch:

Spanning Tree State	<input checked="" type="checkbox"/> Enabled
Spanning Tree Type	RSTP
Priority (0-61440), in steps of 4096	32768

When the Switch Becomes Root:

Input Format: 2 * (hello time + 1) <= max age <= 2 * (forward delay - 1)

Hello Time (1-10)	2	seconds
Maximum Age (6-40)	20	seconds
Forward Delay (4-30)	15	seconds

RSTP Configuration:

Path Cost Method	Long
Transmission Limit (1-10)	3

MSTP Configuration:

Max Instance Numbers	9
Configuration Digest	0xAC36177F50283CD4B83821D8AB26DE62
Region Revision (0-65535)	0
Region Name	00 00 35 28 10 03
Max Hop Count (1-40)	20

Figure 3-89 Configuring Spanning Tree

CLI – This example enables Spanning Tree Protocol, sets the mode to RSTP, and then configures the STA and RSTP parameters.

```

Console (config) #spanning-tree                               4-218
Console (config) #spanning-tree mode rstp                    4-219
Console (config) #spanning-tree priority 45056                4-222
Console (config) #spanning-tree hello-time 5                  4-221
Console (config) #spanning-tree max-age 38                    4-221
Console (config) #spanning-tree forward-time 20               4-220
Console (config) #spanning-tree pathcost method long          4-222
Console (config) #spanning-tree transmission-limit 4          4-223
Console (config) #
  
```

Displaying Interface Settings

The STA Port Information and STA Trunk Information pages display the current status of ports and trunks in the Spanning Tree.

Field Attributes

- **Spanning Tree** – Shows if STA has been enabled on this interface.
- **STA Status** – Displays current state of this port within the Spanning Tree:
 - **Discarding** - Port receives STA configuration messages, but does not forward packets.
 - **Learning** - Port has transmitted configuration messages for an interval set by the Forward Delay parameter without receiving contradictory information. Port address table is cleared, and the port begins learning addresses.
 - **Forwarding** - Port forwards packets, and continues learning addresses.

The rules defining port status are:

- A port on a network segment with no other STA compliant bridging device is always forwarding.
- If two ports of a switch are connected to the same segment and there is no other STA device attached to this segment, the port with the smaller ID forwards packets and the other is discarding.
- All ports are discarding when the switch is booted, then some of them change state to learning, and then to forwarding.
- **Forward Transitions** – The number of times this port has transitioned from the Learning state to the Forwarding state.
- **Designated Cost** – The cost for a packet to travel from this port to the root in the current Spanning Tree configuration. The slower the media, the higher the cost.
- **Designated Bridge** – The bridge priority and MAC address of the device through which this port must communicate to reach the root of the Spanning Tree.
- **Designated Port** – The port priority and number of the port on the designated bridging device through which this switch must communicate with the root of the Spanning Tree.
- **Oper Link Type** – The operational point-to-point status of the LAN segment attached to this interface. This parameter is determined by manual configuration or by auto-detection, as described for Admin Link Type in STA Port Configuration on page 3-148.
- **Oper Edge Port** – This parameter is initialized to the setting for Admin Edge Port in STA Port Configuration on page 3-148 (i.e., true or false), but will be set to false if a BPDU is received, indicating that another bridge is attached to this port.
- **Port Role** – Roles are assigned according to whether the port is part of the active topology connecting the bridge to the root bridge (i.e., **root** port), connecting a LAN through the bridge to the root bridge (i.e., **designated** port), or is an **alternate** or **backup** port that may provide connectivity if other bridges, bridge ports, or LANs fail or are removed. The role is set to disabled (i.e., **disabled** port) if a port has no role within the spanning tree.

Alternate port receives more useful BPDUs from another bridge and is therefore not selected as the designated port.

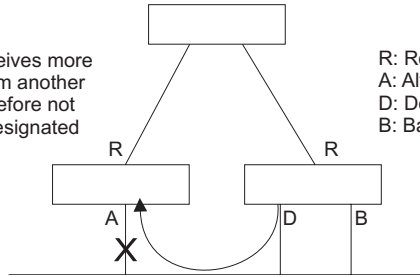

R: Root Port
A: Alternate Port
D: Designated Port
B: Backup Port

Backup port receives more useful BPDUs from the same bridge and is therefore not selected as the designated port.

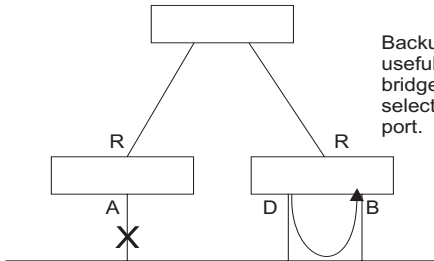

- **Trunk Member** – Indicates if a port is a member of a trunk. (STA Port Information only)

These additional parameters are only displayed for the CLI:

- **Admin status** – Shows if this interface is enabled.
- **Path cost** – This parameter is used by the STA to determine the best path between devices. Therefore, lower values should be assigned to ports attached to faster media, and higher values assigned to ports with slower media. (Path cost takes precedence over port priority.)
- **Priority** – Defines the priority used for this port in the Spanning Tree Algorithm. If the path cost for all ports on a switch is the same, the port with the highest priority (i.e., lowest value) will be configured as an active link in the Spanning Tree. This makes a port with higher priority less likely to be blocked if the Spanning Tree Algorithm is detecting network loops. Where more than one port is assigned the highest priority, the port with the lowest numeric identifier will be enabled.
- **Designated root** – The priority and MAC address of the device in the Spanning Tree that this switch has accepted as the root device.
- **Fast forwarding** – This field provides the same information as Admin Edge port, and is only included for backward compatibility with earlier products.
- **Admin Edge Port** – You can enable this option if an interface is attached to a LAN segment that is at the end of a bridged LAN or to an end node. Since end nodes **cannot** cause forwarding loops, they can pass directly through to the spanning tree forwarding state. Specifying Edge Ports provides quicker convergence for devices such as workstations or servers, retains the current forwarding database to reduce

3 Configuring the Switch

the amount of frame flooding required to rebuild address tables during reconfiguration events, does not cause the spanning tree to reconfigure when the interface changes state, and also overcomes other STA-related timeout problems. However, remember that Edge Port should only be enabled for ports connected to an end-node device.

- **Admin Link Type** – The link type attached to this interface.
 - Point-to-Point – A connection to exactly one other bridge.
 - Shared – A connection to two or more bridges.
 - Auto – The switch automatically determines if the interface is attached to a point-to-point link or to shared media.

Web – Click Spanning Tree, STA, Port Information or STA Trunk Information.

STA Port Information

Port	Spanning Tree	STA Status	Forward Transitions	Designated Cost	Designated Bridge	Designated Port	Oper Link Type	Oper Edge Port	Port Role	Trunk Member
1	Enabled	Forwarding	1	0	32768.0012CF0B0D00	128.1	Point-to-Point	Disabled	Designated	
2	Enabled	Discarding	0	0	32768.0012CF0B0D00	128.2	Point-to-Point	Disabled	Disabled	
3	Enabled	Discarding	0	0	32768.0012CF0B0D00	128.3	Point-to-Point	Disabled	Disabled	
4	Enabled	Discarding	0	0	32768.0012CF0B0D00	128.4	Point-to-Point	Disabled	Disabled	
5	Enabled	Discarding	0	0	32768.0012CF0B0D00	128.5	Point-to-Point	Disabled	Disabled	

Figure 3-90 Displaying Spanning Tree Port Information

CLI – This example shows the STA attributes for port 5.

```
Console#show spanning-tree ethernet 1/5 4-235
Eth 1/ 5 information
-----
Admin status:          enabled
Role:                  disable
State:                 discarding
Path cost:             10000
Priority:               128
Designated cost:      0
Designated port       : 128.5
Designated root:      32768.0012CF0B0D00
Designated bridge:    32768.0012CF0B0D00
Fast forwarding:      disabled
Forward transitions:  0
Admin edge port:      disabled
Oper edge port:       disabled
Admin Link type:      auto
Oper Link type:       point-to-point
Spanning Tree Status: enabled
Console#
```

Configuring Interface Settings

You can configure RSTP and MSTP attributes for specific interfaces, including port priority, path cost, link type, and edge port. You may use a different priority or path cost for ports of the same media type to indicate the preferred path, link type to

indicate a point-to-point connection or shared-media connection, and edge port to indicate if the attached device can support fast forwarding. (References to “ports” in this section means “interfaces,” which includes both ports and trunks.)

Command Attributes

The following attributes are read-only and cannot be changed:

- **STA State** – Displays current state of this port within the Spanning Tree. (See Displaying Interface Settings on page 3-146 for additional information.)
 - **Discarding** - Port receives STA configuration messages, but does not forward packets.
 - **Learning** - Port has transmitted configuration messages for an interval set by the Forward Delay parameter without receiving contradictory information. Port address table is cleared, and the port begins learning addresses.
 - **Forwarding** - Port forwards packets, and continues learning addresses.
- **Trunk** – Indicates if a port is a member of a trunk. (STA Port Configuration only)

The following interface attributes can be configured:

- **Spanning Tree** – Enables/disables STA on this interface. (Default: Enabled).
- **Priority** – Defines the priority used for this port in the Spanning Tree Protocol. If the path cost for all ports on a switch are the same, the port with the highest priority (i.e., lowest value) will be configured as an active link in the Spanning Tree. This makes a port with higher priority less likely to be blocked if the Spanning Tree Protocol is detecting network loops. Where more than one port is assigned the highest priority, the port with lowest numeric identifier will be enabled.
 - Default: 128
 - Range: 0-240, in steps of 16
- **Path Cost** – This parameter is used by the STP to determine the best path between devices. Therefore, lower values should be assigned to ports attached to faster media, and higher values assigned to ports with slower media. (Path cost takes precedence over port priority.) Note that when the Path Cost Method is set to short, the maximum path cost is 65,535.
 - Range –
 - Ethernet: 200,000-20,000,000
 - Fast Ethernet: 20,000-2,000,000
 - Gigabit Ethernet: 2,000-200,000
 - Default –
 - Ethernet – Half duplex: 2,000,000; full duplex: 1,000,000; trunk: 500,000
 - Fast Ethernet – Half duplex: 200,000; full duplex: 100,000; trunk: 50,000
 - Gigabit Ethernet – Full duplex: 10,000; trunk: 5,000
- **Admin Link Type** – The link type attached to this interface.
 - Point-to-Point – A connection to exactly one other bridge.
 - Shared – A connection to two or more bridges.
 - Auto – The switch automatically determines if the interface is attached to a point-to-point link or to shared media. (This is the default setting.)

3 Configuring the Switch

- **Admin Edge Port (Fast Forwarding)** – You can enable this option if an interface is attached to a LAN segment that is at the end of a bridged LAN or to an end node. Since end nodes **cannot** cause forwarding loops, they can pass directly through to the spanning tree forwarding state. Specifying Edge Ports provides quicker convergence for devices such as workstations or servers, retains the current forwarding database to reduce the amount of frame flooding required to rebuild address tables during reconfiguration events, does not cause the spanning tree to initiate reconfiguration when the interface changes state, and also overcomes other STA-related timeout problems. However, remember that Edge Port should only be enabled for ports connected to an end-node device. (Default: Disabled)
- **Migration** – If at any time the switch detects STP BPDUs, including Configuration or Topology Change Notification BPDUs, it will automatically set the selected interface to forced STP-compatible mode. However, you can also use the Protocol Migration button to manually re-check the appropriate BPDU format (RSTP or STP-compatible) to send on the selected interfaces. (Default: Disabled)

Web – Click Spanning Tree, STA, Port Configuration or Trunk Configuration. Modify the required attributes, then click Apply.

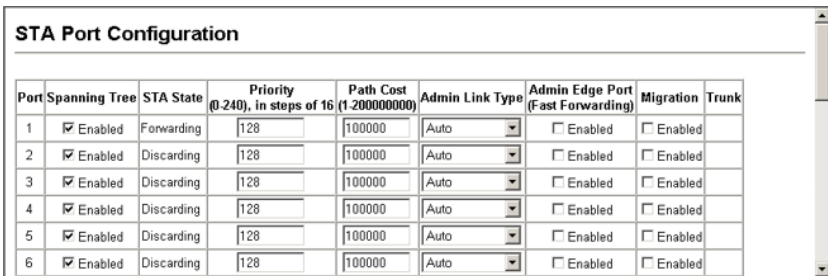

Port	Spanning Tree	STA State	Priority (0-240), in steps of 16	Path Cost (1-20000000)	Admin Link Type	Admin Edge Port (Fast Forwarding)	Migration	Trunk
1	<input checked="" type="checkbox"/> Enabled	Forwarding	128	100000	Auto	<input type="checkbox"/> Enabled	<input type="checkbox"/> Enabled	
2	<input checked="" type="checkbox"/> Enabled	Discarding	128	100000	Auto	<input type="checkbox"/> Enabled	<input type="checkbox"/> Enabled	
3	<input checked="" type="checkbox"/> Enabled	Discarding	128	100000	Auto	<input type="checkbox"/> Enabled	<input type="checkbox"/> Enabled	
4	<input checked="" type="checkbox"/> Enabled	Discarding	128	100000	Auto	<input type="checkbox"/> Enabled	<input type="checkbox"/> Enabled	
5	<input checked="" type="checkbox"/> Enabled	Discarding	128	100000	Auto	<input type="checkbox"/> Enabled	<input type="checkbox"/> Enabled	
6	<input checked="" type="checkbox"/> Enabled	Discarding	128	100000	Auto	<input type="checkbox"/> Enabled	<input type="checkbox"/> Enabled	

Figure 3-91 Configuring Spanning Tree per Port

CLI – This example sets STA attributes for port 7.

```
Console(config)#interface ethernet 1/7 4-166
Console(config-if)#spanning-tree port-priority 0 4-228
Console(config-if)#spanning-tree cost 50 4-227
Console(config-if)#spanning-tree link-type auto 4-231
Console(config-if)#no spanning-tree edge-port 4-229
Console(config-if)#
```

Configuring Multiple Spanning Trees

MSTP generates a unique spanning tree for each instance. This provides multiple pathways across the network, thereby balancing the traffic load, preventing wide-scale disruption when a bridge node in a single instance fails, and allowing for faster convergence of a new topology for the failed instance.

By default all VLANs are assigned to the Internal Spanning Tree (MST Instance 0) that connects all bridges and LANs within the MST region. This switch supports up to 9 instances. You should try to group VLANs which cover the same general area of

your network. However, remember that you must configure all bridges within the same MSTI Region (page 3-133) with the same set of instances, and the same instance (on each bridge) with the same set of VLANs. Also, note that RSTP treats each MSTI region as a single node, connecting all regions to the Common Spanning Tree.

To use multiple spanning trees:

1. Set the spanning tree type to MSTP (STA Configuration, page 3-130).
2. Enter the spanning tree priority for the selected MST instance (MSTP VLAN Configuration).
3. Add the VLANs that will share this MSTI (MSTP VLAN Configuration). Note: All VLANs are automatically added to the IST (Instance 0).

To ensure that the MSTI maintains connectivity across the network, you must configure a related set of bridges with the same MSTI settings.

Command Attributes

- **MST Instance** – Instance identifier of this spanning tree. (Default: 0)
- **Priority** – The priority of a spanning tree instance. (Range: 0-61440 in steps of 4096; Options: 0, 4096, 8192, 12288, 16384, 20480, 24576, 28672, 32768, 36864, 40960, 45056, 49152, 53248, 57344, 61440; Default: 32768)
- **VLANs in MST Instance** – VLANs assigned to this instance.
- **MST ID** – Instance identifier to configure. (Range: 0-57; Default: 0)
- **VLAN ID** – VLAN to assign to this selected MST instance. (Range: 1-4092)

3 Configuring the Switch

Web – Click Spanning Tree, MSTP, VLAN Configuration. Select an instance identifier from the list, set the instance priority, and click Apply. To add the VLAN members to an MSTI instance, enter the instance identifier, the VLAN identifier, and click Add.

MSTP VLAN Configuration

MST Instance ID: 0 ▾

Spanning Tree State	Enabled	Designated Root	32768.000035281003
Bridge ID	32768.000035281003	Root Port	0
Max Age	20	Root Path Cost	0
Hello Time	2	Configuration Changes	0
Forward Delay	15	Last Topology Change	0 d 4 h 21 min 45 s

Priority (0-61440): 32768

MSTP VLAN Configuration:

VLAN in MST Instance:

VLAN 1
VLAN 2
VLAN 3
VLAN 4
VLAN 5

Remove

MST ID (0-4094): VLAN ID: Add

Figure 3-92 Configuring Multiple Spanning Trees

CLI – This example sets the priority for MSTI 1, and adds VLANs 1-5 to this MSTI.

```
Console(config)#spanning-tree mst configuration 4-223
Console(config-mst)#mst 1 priority 4096 4-225
Console(config-mstp)#mst 1 vlan 1-5 4-224
Console(config-mst)#
```

CLI – This example sets STA attributes for port 1, followed by settings for each port.

```

Console#show spanning-tree mst 2
Spanning-tree information
-----
Spanning tree mode :MSTP
Spanning tree enable/disable :enable
Instance :2
Vlans configuration :2
Priority :4096
Bridge Hello Time (sec.) :2
Bridge Max Age (sec.) :20
Bridge Forward Delay (sec.) :15
Root Hello Time (sec.) :2
Root Max Age (sec.) :20
Root Forward Delay (sec.) :15
Max hops :20
Remaining hops :20
Designated Root :4096.2.0000E9313131
Current root port :0
Current root cost :0
Number of topology changes :0
Last topology changes time (sec.):646
Transmission limit :3
Path Cost Method :long
-----
Eth 1/ 7 information
-----
Admin status : enable
Role : disable
State : discarding
External path cost : 10000
Internal path cost : 10000
Priority : 128
Designated cost : 0
Designated port : 128.7
Designated root : 4096.2.0000E9313131
Designated bridge : 4096.2.0000E9313131
Fast forwarding : enable
Forward transitions : 0
Admin edge port : enable
Oper edge port : enable
Admin Link type : auto
Oper Link type : point-to-point
Spanning Tree Status : enable
...

```

Displaying Interface Settings for MSTP

The MSTP Port Information and MSTP Trunk Information pages display the current status of ports and trunks in the selected MST instance.

Command Attributes

- **MST Instance ID** – Instance identifier to configure. (Default: 0)

Note: The other attributes are described under “Displaying Interface Settings” on page 3-146

3 Configuring the Switch

Web – Click Spanning Tree, MSTP, Port or Trunk Information. Select the required MST instance to display the current spanning tree values.

MSTP Port Information										
MST Instance ID: <input type="text" value="0"/>										
Port	STA Status	Forward Transitions	Designated Cost	Designated Bridge	Designated Port	Oper Path Cost	Oper Link Type	Oper Edge Port	Port Role	Trunk Member
1	Discarding	0	0	32768.000035281003	128.1	2000000	Shared	Enabled	Disabled	
2	Discarding	0	0	32768.000035281003	128.2	2000000	Shared	Enabled	Disabled	
3	Discarding	0	0	32768.000035281003	128.3	2000000	Shared	Enabled	Disabled	
4	Discarding	0	0	32768.000035281003	128.4	2000000	Shared	Enabled	Disabled	
5	Forwarding	1	0	32768.000035281003	128.5	1000000	Point-to-Point	Enabled	Designated	
6	Discarding	0	0	32768.000035281003	128.6	2000000	Shared	Enabled	Disabled	
7	Discarding	0	0	32768.000035281003	128.7	2000000	Shared	Enabled	Disabled	
8	Discarding	0	0	32768.000035281003	128.8	2000000	Shared	Enabled	Disabled	
9	Discarding	0	0	32768.000035281003	128.9	2000000	Shared	Enabled	Disabled	
10	Discarding	0	0	32768.000035281003	128.10	2000000	Shared	Enabled	Disabled	
11	Discarding	0	0	32768.000035281003	128.11	2000000	Shared	Enabled	Disabled	
12	Discarding	0	0	32768.000035281003	128.12	2000000	Shared	Enabled	Disabled	
13	Discarding	0	0	32768.000035281003	128.13	2000000	Shared	Enabled	Disabled	

Figure 3-93 Displaying MSTP Interface Settings

CLI – This displays STA settings for instance 0, followed by settings for each port. The settings for instance 0 are global settings that apply to the IST, the settings for other instances only apply to the local spanning tree.

```

Console#show spanning-tree mst 0 4-231                                     4-235
Spanning-tree information
-----
Spanning tree mode :MSTP
Spanning tree enable/disable :enable
Instance :0
Vlans configuration :1-4092
Priority :32768
Bridge Hello Time (sec.) :2
Bridge Max Age (sec.) :20
Bridge Forward Delay (sec.) :15
Root Hello Time (sec.) :2
Root Max Age (sec.) :20
Root Forward Delay (sec.) :15
Max hops :20
Remaining hops :20
Designated Root :32768.0.0000ABCD0000
Current root port :1
Current root cost :200000
Number of topology changes :1
Last topology changes time (sec.):645
Transmission limit :3
Path Cost Method :long
-----
Eth 1/ 1 information
-----
Admin status : enable
Role : root
State : forwarding
External path cost : 100000
Internal path cost : 100000
Priority : 128
Designated cost : 200000
Designated port : 128.24
Designated root : 32768.0.0000ABCD0000
Designated bridge : 32768.0.0030F1552000
Fast forwarding : disable
Forward transitions : 1
Admin edge port : enable
Oper edge port : disable
Admin Link type : auto
Oper Link type : point-to-point
Spanning Tree Status : enable
...

```

Configuring Interface Settings for MSTP

You can configure the STA interface settings for an MST Instance using the MSTP Port Configuration and MSTP Trunk Configuration pages.

Field Attributes

The following attributes are read-only and cannot be changed:

- **STA State** – Displays current state of this port within the Spanning Tree. (See “Displaying Interface Settings” on page 3-146 for additional information.)

3 Configuring the Switch

- **Discarding** – Port receives STA configuration messages, but does not forward packets.
- **Learning** – Port has transmitted configuration messages for an interval set by the Forward Delay parameter without receiving contradictory information. Port address table is cleared, and the port begins learning addresses.
- **Forwarding** – Port forwards packets, and continues learning addresses.
- **Trunk** – Indicates if a port is a member of a trunk. (STA Port Configuration only)

The following interface attributes can be configured:

- **MST Instance ID** – Instance identifier to configure. (Default: 0)
- **Priority** – Defines the priority used for this port in the Spanning Tree Protocol. If the path cost for all ports on a switch are the same, the port with the highest priority (i.e., lowest value) will be configured as an active link in the Spanning Tree. This makes a port with higher priority less likely to be blocked if the Spanning Tree Protocol is detecting network loops. Where more than one port is assigned the highest priority, the port with lowest numeric identifier will be enabled. (Default: 128; Range: 0-240, in steps of 16)
- **MST Path Cost** – This parameter is used by the MSTP to determine the best path between devices. Therefore, lower values should be assigned to ports attached to faster media, and higher values assigned to ports with slower media. (Path cost takes precedence over port priority.) Note that when the Path Cost Method is set to short (page 3-63), the maximum path cost is 65,535.
 - Range:
 - Ethernet: 200,000-20,000,000
 - Fast Ethernet: 20,000-2,000,000
 - Gigabit Ethernet: 2,000-200,000
 - Default:
 - Ethernet – Half duplex: 2,000,000; full duplex: 1,000,000; trunk: 500,000
 - Fast Ethernet – Half duplex: 200,000; full duplex: 100,000; trunk: 50,000
 - Gigabit Ethernet – Full duplex: 10,000; trunk: 5,000

Web – Click Spanning Tree, MSTP, Port Configuration or Trunk Configuration. Enter the priority and path cost for an interface, and click Apply.

MSTP Port Configuration

MST Instance ID: 0

Port	STA State	Priority (0-240), in steps of 16	Admin MST Path Cost (1-200000000, 0:Auto)	Trunk
1	Discarding	128	0	
2	Discarding	128	0	
3	Discarding	128	0	
4	Discarding	128	0	
5	Forwarding	128	0	
6	Discarding	128	0	
7	Discarding	128	0	
8	Discarding	128	0	
9	Discarding	128	0	

Figure 3-94 Displaying MSTP Interface Settings

CLI – This example sets the MSTP attributes for port 4.

```
Console(config)#interface ethernet 1/4
Console(config-if)#spanning-tree mst port-priority 0
Console(config-if)#spanning-tree mst cost 50
Console(config-if)
```

VLAN Configuration

IEEE 802.1Q VLANs

In large networks, routers are used to isolate broadcast traffic for each subnet into separate domains. This switch provides a similar service at Layer 2 by using VLANs to organize any group of network nodes into separate broadcast domains. VLANs confine broadcast traffic to the originating group, and can eliminate broadcast storms in large networks. This also provides a more secure and cleaner network environment.

An IEEE 802.1Q VLAN is a group of ports that can be located anywhere in the network, but communicate as though they belong to the same physical segment.

VLANs help to simplify network management by allowing you to move devices to a new VLAN without having to change any physical connections. VLANs can be easily organized to reflect departmental groups (such as Marketing or R&D), usage groups (such as e-mail), or multicast groups (used for multimedia applications such as videoconferencing).

VLANs provide greater network efficiency by reducing broadcast traffic, and allow you to make network changes without having to update IP addresses or IP subnets. VLANs inherently provide a high level of network security since traffic must pass through a configured Layer 3 link to reach a different VLAN.

3 Configuring the Switch

This switch supports the following VLAN features:

- Up to 255 VLANs based on the IEEE 802.1Q standard
- Distributed VLAN learning across multiple switches using explicit or implicit tagging and GVRP protocol
- Port overlapping, allowing a port to participate in multiple VLANs
- End stations can belong to multiple VLANs
- Passing traffic between VLAN-aware and VLAN-unaware devices
- Priority tagging

Note: The switch allows 255 user-manageable VLANs. One extra, unmanageable VLAN (VLAN ID 4093) is maintained for switch clustering.

Assigning Ports to VLANs

Before enabling VLANs for the switch, you must first assign each port to the VLAN group(s) in which it will participate. By default all ports are assigned to VLAN 1 as untagged ports. Add a port as a tagged port if you want it to carry traffic for one or more VLANs, and any intermediate network devices or the host at the other end of the connection supports VLANs. Then assign ports on the other VLAN-aware network devices along the path that will carry this traffic to the same VLAN(s), either manually or dynamically using GVRP. However, if you want a port on this switch to participate in one or more VLANs, but none of the intermediate network devices nor the host at the other end of the connection supports VLANs, then you should add this port to the VLAN as an untagged port.

Note: VLAN-tagged frames can pass through VLAN-aware or VLAN-unaware network interconnection devices, but the VLAN tags should be stripped off before passing it on to any end-node host that does not support VLAN tagging.

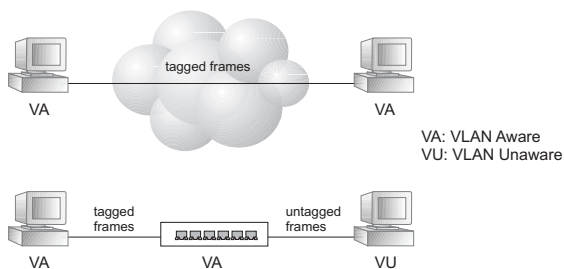

VLAN Classification – When the switch receives a frame, it classifies the frame in one of two ways. If the frame is untagged, the switch assigns the frame to an associated VLAN (based on the default VLAN ID of the receiving port). But if the frame is tagged, the switch uses the tagged VLAN ID to identify the port broadcast domain of the frame.

Port Overlapping – Port overlapping can be used to allow access to commonly shared network resources among different VLAN groups, such as file servers or printers. Note that if you implement VLANs which do not overlap, but still need to communicate, you can connect them by enabled routing on this switch.

Untagged VLANs – Untagged (or static) VLANs are typically used to reduce broadcast traffic and to increase security. A group of network users assigned to a VLAN form a broadcast domain that is separate from other VLANs configured on the switch. Packets are forwarded only between ports that are designated for the same VLAN. Untagged VLANs can be used to manually isolate user groups or subnets. However, you should use IEEE 802.3 tagged VLANs with GVRP whenever possible to fully automate VLAN registration.

Automatic VLAN Registration – GVRP (GARP VLAN Registration Protocol) defines a system whereby the switch can automatically learn the VLANs to which each end station should be assigned. If an end station (or its network adapter) supports the IEEE 802.1Q VLAN protocol, it can be configured to broadcast a message to your network indicating the VLAN groups it wants to join. When this switch receives these messages, it will automatically place the receiving port in the specified VLANs, and then forward the message to all other ports. When the message arrives at another switch that supports GVRP, it will also place the receiving port in the specified VLANs, and pass the message on to all other ports. VLAN requirements are propagated in this way throughout the network. This allows GVRP-compliant devices to be automatically configured for VLAN groups based solely on endstation requests.

To implement GVRP in a network, first add the host devices to the required VLANs (using the operating system or other application software), so that these VLANs can be propagated onto the network. For both the edge switches attached directly to these hosts, and core switches in the network, enable GVRP on the links between these devices. You should also determine security boundaries in the network and disable GVRP on the boundary ports to prevent advertisements from being propagated, or forbid those ports from joining restricted VLANs.

Note: If you have host devices that do not support GVRP, you should configure static or untagged VLANs for the switch ports connected to these devices (as described in “Adding Static Members to VLANs (VLAN Index)” on page 3-164). But you can still enable GVRP on these edge switches, as well as on the core switches in the network.

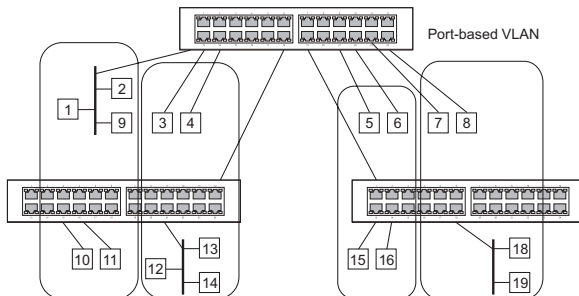

3 Configuring the Switch

Forwarding Tagged/Untagged Frames

If you want to create a small port-based VLAN for devices attached directly to a single switch, you can assign ports to the same untagged VLAN. However, to participate in a VLAN group that crosses several switches, you should create a VLAN for that group and enable tagging on all ports.

Ports can be assigned to multiple tagged VLANs, but are only allowed one untagged VLAN. Each port on the switch is capable of passing tagged or untagged frames. When forwarding a frame from this switch along a path that contains any VLAN-aware devices, the switch should include VLAN tags. When forwarding a frame from this switch along a path that does not contain any VLAN-aware devices (including the destination host), the switch must first strip off the VLAN tag before forwarding the frame. When the switch receives a tagged frame, it will pass this frame onto the VLAN(s) indicated by the frame tag. However, when this switch receives an untagged frame from a VLAN-unaware device, it first decides where to forward the frame, and then inserts a VLAN tag reflecting the ingress port's default VID.

Enabling or Disabling GVRP (Global Setting)

GARP VLAN Registration Protocol (GVRP) defines a way for switches to exchange VLAN information in order to register VLAN members on ports across the network. VLANs are dynamically configured based on join messages issued by host devices and propagated throughout the network. GVRP must be enabled to permit automatic VLAN registration, and to support VLANs which extend beyond the local switch. (Default: Disabled)

Web – Click VLAN, 802.1Q VLAN, GVRP Status. Enable or disable GVRP, click Apply



Figure 3-95 Globally Enabling GVRP

CLI – This example enables GVRP for the switch.

```
Console(config)#bridge-ext gvrp
Console(config)#
```

4-168

Displaying Basic VLAN Information

The VLAN Basic Information page displays basic information on the VLAN type supported by the switch.

Field Attributes

- **VLAN Version Number**¹⁰ – The VLAN version used by this switch as specified in the IEEE 802.1Q standard.
- **Maximum VLAN ID** – Maximum VLAN ID recognized by this switch.
- **Maximum Number of Supported VLANs** – Maximum number of VLANs that can be configured on this switch.

Web – Click VLAN, 802.1Q VLAN, Basic Information.

VLAN Basic Information	
VLAN Version Number	1
Maximum VLAN ID	4092
Maximum Number of Supported VLANs	256

Figure 3-96 Displaying Basic VLAN Information

CLI – Enter the following command.

```

Console#show bridge-ext                                     4-239
Max support vlan numbers:                                256
Max support vlan ID:                                     4092
Extended multicast filtering services: No
Static entry individual port:                            Yes
VLAN learning:                                          IVL
Configurable PVID tagging:                              Yes
Local VLAN capable:                                     No
Traffic classes:                                        Enabled
Global GVRP status:                                    Enabled
GMRP:                                                   Disabled
Console#

```

Displaying Current VLANs

The VLAN Current Table shows the current port members of each VLAN and whether or not the port supports VLAN tagging. Ports assigned to a large VLAN group that crosses several switches should use VLAN tagging. However, if you just want to create a small port-based VLAN for one or two switches, you can disable tagging.

Command Attributes (Web)

- **VLAN ID** – ID of configured VLAN (1-4093).
- **Up Time at Creation** – Time this VLAN was created (i.e., System Up Time).

10. Web Only.

3 Configuring the Switch

- **Status** – Shows how this VLAN was added to the switch.
 - **Dynamic GVRP**: Automatically learned via GVRP.
 - **Permanent**: Added as a static entry.
- **Egress Ports** – Shows all the VLAN port members.
- **Untagged Ports** – Shows the untagged VLAN port members.

Web – Click VLAN, 802.1Q VLAN, Current Table. Select any ID from the scroll-down list.

VLAN Current Table

VLAN ID:

Up Time at Creation: 0 d 0 h 0 min 18 s

Status: Permanent

Egress Ports

- Unit1 Port1
- Unit1 Port2
- Unit1 Port3
- Unit1 Port4
- Unit1 Port5
- Unit1 Port6
- Unit1 Port7
- Unit1 Port8

Untagged Ports

- Unit1 Port1
- Unit1 Port2
- Unit1 Port3
- Unit1 Port4
- Unit1 Port5
- Unit1 Port6
- Unit1 Port7
- Unit1 Port8

Figure 3-97 Displaying Current VLANs

Command Attributes (CLI)

- **VLAN** – ID of configured VLAN (1-4092, no leading zeroes).
- **Type** – Shows how this VLAN was added to the switch.
 - **Dynamic**: Automatically learned via GVRP.
 - **Static**: Added as a static entry.
- **Name** – Name of the VLAN (1 to 32 characters).
- **Status** – Shows if this VLAN is enabled or disabled.
 - **Active**: VLAN is operational.
 - **Suspend**: VLAN is suspended; i.e., does not pass packets.
- **Ports / Channel groups** – Shows the VLAN interface members.

CLI – Current VLAN information can be displayed with the following command.

```
Console#show vlan id 1 4-250
Vlan ID:                1
Type:                   Static
Name:                   DefaultVlan
Status:                 Active
Ports/Port channel:    Eth1/ 1(S) Eth1/ 2(S) Eth1/ 3(S) Eth1/ 4(S) Eth1/ 5(S)
                       Eth1/ 6(S) Eth1/ 7(S) Eth1/ 8(S) Eth1/ 9(S) Eth1/10(S)
                       Eth1/11(S) Eth1/12(S) Eth1/13(S) Eth1/14(S) Eth1/15(S)
                       Eth1/16(S) Eth1/17(S) Eth1/18(S) Eth1/19(S) Eth1/20(S)
                       Eth1/21(S) Eth1/22(S) Eth1/23(S) Eth1/24(S) Eth1/25(S)
                       Eth1/26(S) Eth1/27(S) Eth1/28(S)
Console#
```

Creating VLANs

Use the VLAN Static List to create or remove VLAN groups. To propagate information about VLAN groups used on this switch to external network devices, you must specify a VLAN ID for each of these groups.

Command Attributes

- **Current** – Lists all the current VLAN groups created for this system. Up to 255 VLAN groups can be defined. VLAN 1 is the default untagged VLAN. VLAN 4093 is reserved for switch clustering and is not user-configurable or removable.
- **New** – Allows you to specify the name and numeric identifier for a new VLAN group. (The VLAN name is only used for management on this system; it is not added to the VLAN tag.)
- **VLAN ID** – ID of configured VLAN (1-4092, no leading zeroes).
- **VLAN Name** – Name of the VLAN (1 to 32 characters, no spaces).
- **Status (Web)** – Enables or disables the specified VLAN.
 - **Enabled:** VLAN is operational.
 - **Disabled:** VLAN is suspended; i.e., does not pass packets.
- **State (CLI)** – Enables or disables the specified VLAN.
 - **Active:** VLAN is operational.
 - **Suspend:** VLAN is suspended; i.e., does not pass packets.
- **Add** – Adds a new VLAN group to the current list.
- **Remove** – Removes a VLAN group from the current list. If any port is assigned to this group as untagged, it will be reassigned to VLAN group 1 as untagged.

3 Configuring the Switch

Web – Click VLAN, 802.1Q VLAN, Static List. To create a new VLAN, enter the VLAN ID and VLAN name, mark the Enable checkbox to activate the VLAN, and then click Add.

VLAN Static List

Current:		New:					
<table border="1"><tr><td>1, DefaultVlan, Enabled</td></tr><tr><td>1024, usr-vlan-1024, Enabled</td></tr><tr><td>2048, usr-vlan-2048, Disabled</td></tr><tr><td>4092, usr-vlan-4092, Enabled</td></tr><tr><td>4093, . Enabled</td></tr></table>	1, DefaultVlan, Enabled	1024, usr-vlan-1024, Enabled	2048, usr-vlan-2048, Disabled	4092, usr-vlan-4092, Enabled	4093, . Enabled	<input type="button" value="<<Add"/>	VLAN ID (1-4092) <input type="text"/>
1, DefaultVlan, Enabled							
1024, usr-vlan-1024, Enabled							
2048, usr-vlan-2048, Disabled							
4092, usr-vlan-4092, Enabled							
4093, . Enabled							
<input type="button" value="Remove"/>		VLAN Name <input type="text"/>					
		Status <input type="checkbox"/> Enabled					

Figure 3-98 Configuring a VLAN Static List

CLI – This example creates a new VLAN.

```
Console(config)#vlan database 4-242
Console(config-vlan)#vlan 2 name R&D media ethernet state active 4-243
Console(config-vlan)#end
Console#show vlan 4-250
Vlan ID: 1
Type: Static
Name: DefaultVlan
Status: Active
Ports/Port channel: Eth1/ 1(S) Eth1/ 2(S) Eth1/ 3(S) Eth1/ 4(S) Eth1/ 5(S)
Eth1/ 6(S) Eth1/ 7(S) Eth1/ 8(S) Eth1/ 9(S) Eth1/10(S)
Eth1/11(S) Eth1/12(S) Eth1/13(S) Eth1/14(S) Eth1/15(S)
Eth1/16(S) Eth1/17(S) Eth1/18(S) Eth1/19(S) Eth1/20(S)
Eth1/21(S) Eth1/22(S) Eth1/23(S) Eth1/24(S) Eth1/25(S)
Eth1/26(S) Eth1/27(S) Eth1/28(S)

Vlan ID: 2
Type: Static
Name: R&D
Status: Active
Ports/Port Channel:

Console#
```

Adding Static Members to VLANs (VLAN Index)

Use the VLAN Static Table to configure port members for the selected VLAN index. Assign ports as tagged if they are connected to 802.1Q VLAN compliant devices, or untagged they are not connected to any VLAN-aware devices. Or configure a port as forbidden to prevent the switch from automatically adding it to a VLAN via the GVRP protocol.

- Notes:**
1. You can also use the VLAN Static Membership by Port page to configure VLAN groups based on the port index (page 3-166). However, note that this configuration page can only add ports to a VLAN as tagged members.
 2. VLAN 1 is the default untagged VLAN containing all ports on the switch, and can only be modified by first reassigning the default port VLAN ID as described under “Configuring VLAN Behavior for Interfaces” on page 3-167.

Command Attributes

- **VLAN** – ID of configured VLAN (1-4093).
- **Name** – Name of the VLAN (1 to 32 characters).
- **Status** – Enables or disables the specified VLAN.
 - **Enable:** VLAN is operational.
 - **Disable:** VLAN is suspended; i.e., does not pass packets.
- **Port** – Port identifier.
- **Membership Type** – Select VLAN membership for each interface by marking the appropriate radio button for a port or trunk:
 - **Tagged:** Interface is a member of the VLAN. All packets transmitted by the port will be tagged, that is, carry a tag and therefore carry VLAN or CoS information.
 - **Untagged:** Interface is a member of the VLAN. All packets transmitted by the port will be untagged, that is, not carry a tag and therefore not carry VLAN or CoS information. Note that an interface can only have one untagged VLAN, which must be the same as the Port VID. See “Configuring VLAN Behavior for Interfaces” on page 3-167 for configuring PVID.
 - **Forbidden:** Interface is forbidden from automatically joining the VLAN via GVRP. For more information, see “Automatic VLAN Registration” on page 3-159.
 - **None:** Interface is not a member of the VLAN. Packets associated with this VLAN will not be transmitted by the interface.
 - **Trunk Member** – Indicates if a port is a member of a trunk. To add a trunk to the selected VLAN, use the last table on the VLAN Static Table page.

Web – Click VLAN, 802.1Q VLAN, Static Table. Select a VLAN ID from the scroll-down list. Modify the VLAN name and status if required. Select the membership type by marking the appropriate radio button in the list of ports or trunks. Click Apply.

VLAN Static Table

VLAN:

Name	<input type="text" value="R&D"/>
Status	<input checked="" type="checkbox"/> Enable

Port	Tagged	Untagged	Forbidden	None	Trunk Member
1	<input checked="" type="radio"/>	<input type="radio"/>	<input type="radio"/>	<input type="radio"/>	
2	<input type="radio"/>	<input checked="" type="radio"/>	<input type="radio"/>	<input type="radio"/>	
3	<input type="radio"/>	<input type="radio"/>	<input type="radio"/>	<input checked="" type="radio"/>	
4	<input type="radio"/>	<input type="radio"/>	<input type="radio"/>	<input checked="" type="radio"/>	
5	<input type="radio"/>	<input type="radio"/>	<input type="radio"/>	<input checked="" type="radio"/>	

Figure 3-99 Configuring a VLAN Static Table

CLI – The following example adds tagged and untagged ports to VLAN 2.

```
Console(config)#interface ethernet 1/1                                4-166
Console(config-if)#switchport allowed vlan add 2 tagged             4-248
Console(config-if)#exit
Console(config)#interface ethernet 1/2
Console(config-if)#switchport allowed vlan add 2 untagged
Console(config-if)#exit
Console(config)#interface ethernet 1/13
Console(config-if)#switchport allowed vlan add 2 tagged
```

Adding Static Members to VLANs (Port Index)

Use the VLAN Static Membership by Port menu to assign VLAN groups to the selected interface as a tagged member.

Command Attributes

- **Interface** – Port or trunk identifier.
- **Member** – VLANs for which the selected interface is a tagged member.
- **Non-Member** – VLANs for which the selected interface is not a tagged member.

Web – Open VLAN, 802.1Q VLAN, Static Membership by Port. Select an interface from the scroll-down box (Port or Trunk). Click Query to display membership information for the interface. Select a VLAN ID, and then click Add to add the interface as a tagged member, or click Remove to remove the interface. After configuring VLAN membership for each interface, click Apply.

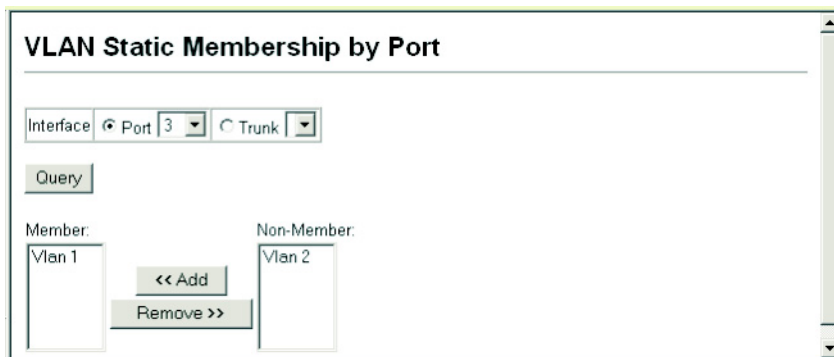

Figure 3-100 VLAN Static Membership by Port

CLI – This example adds Port 3 to VLAN 1 as a tagged port, and removes Port 3 from VLAN 2.

```
Console(config)#interface ethernet 1/3                                4-166
Console(config-if)#switchport allowed vlan add 1 tagged             4-248
Console(config-if)#switchport allowed vlan remove 2
```

Configuring VLAN Behavior for Interfaces

You can configure VLAN behavior for specific interfaces, including the default VLAN identifier (PVID), accepted frame types, ingress filtering, GVRP status, and GARP timers.

Command Usage

- **GVRP** – GARP VLAN Registration Protocol defines a way for switches to exchange VLAN information in order to automatically register VLAN members on interfaces across the network.
- **GARP** – Group Address Registration Protocol is used by GVRP to register or deregister client attributes for client services within a bridged LAN. The default values for the GARP timers are independent of the media access method or data rate. These values should not be changed unless you are experiencing difficulties with GVRP registration/deregistration.

Command Attributes

- **PVID** – VLAN ID assigned to untagged frames received on the interface. (Default: 1)
 - If an interface is not a member of VLAN 1 and you assign its PVID to this VLAN, the interface will automatically be added to VLAN 1 as an untagged member. For all other VLANs, the PVID must be defined first, then the status of the VLAN can be configured as a tagged or untagged member.
- **Acceptable Frame Type** – Sets the interface to accept all frame types, including tagged or untagged frames, or only tagged frames. When set to receive all frame types, any received frames that are untagged are assigned to the default VLAN. (Options: All, Tagged; Default: All)
- **Ingress Filtering** – Determines how to process frames tagged for VLANs for which the ingress port is not a member. Ingress Filtering is always enabled. (Default: Enabled)
 - Ingress filtering only affects tagged frames.
 - If a port receives frames tagged for VLANs for which it is not a member, these frames will be discarded.
 - Ingress filtering does not affect VLAN independent BPDU frames, such as GVRP or STP. However, they do affect VLAN dependent BPDU frames, such as GMRP.
- **GVRP Status** – Enables/disables GVRP for the interface. GVRP must be globally enabled for the switch before this setting can take effect. (See “Displaying Bridge Extension Capabilities” on page 3-15.) When disabled, any GVRP packets received on this port will be discarded and no GVRP registrations will be propagated from other ports. (Default: Disabled)
- **GARP Join Timer**¹¹ – The interval between transmitting requests/queries to participate in a VLAN group. (Range: 20-1000 centiseconds; Default: 20)
- **GARP Leave Timer**⁹ – The interval a port waits before leaving a VLAN group. This time should be set to more than twice the join time. This ensures that after a Leave

11. Timer settings must follow this rule: 2 x (join timer) < leave timer < leaveAll timer

3 Configuring the Switch

or LeaveAll message has been issued, the applicants can rejoin before the port actually leaves the group. (Range: 60-3000 centiseconds; Default: 60)

- **GARP LeaveAll Timer⁹** – The interval between sending out a LeaveAll query message for VLAN group participants and the port leaving the group. This interval should be considerably larger than the Leave Time to minimize the amount of traffic generated by nodes rejoining the group.
(Range: 500-18000 centiseconds; Default: 1000)
- **Mode** – Indicates VLAN membership mode for an interface. (Default: Hybrid)
 - **1Q Trunk** – Specifies a port as an end-point for a VLAN trunk. A trunk is a direct link between two switches, so the port transmits tagged frames that identify the source VLAN. Note that frames belonging to the port's default VLAN (i.e., associated with the PVID) are also transmitted as tagged frames.
 - **Hybrid** – Specifies a hybrid VLAN interface. The port may transmit tagged or untagged frames.
- **Trunk Member** – Indicates if a port is a member of a trunk. To add a trunk to the selected VLAN, use the last table on the VLAN Static Table page.

Web – Click VLAN, 802.1Q VLAN, Port Configuration or Trunk Configuration. Fill in the required settings for each interface, click Apply.

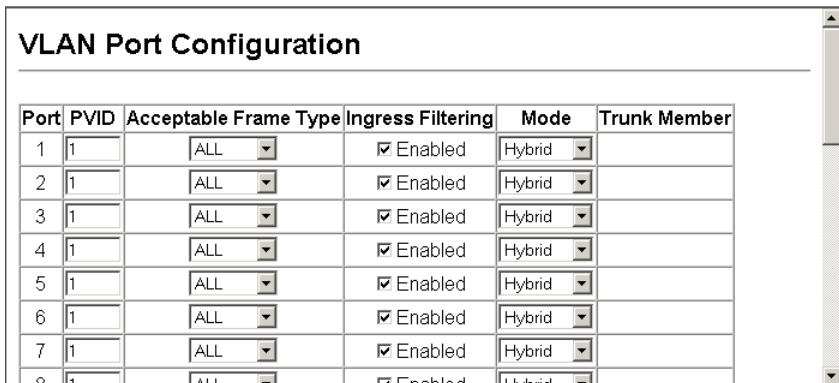

Port	PVID	Acceptable Frame Type	Ingress Filtering	Mode	Trunk Member
1	1	ALL	<input checked="" type="checkbox"/> Enabled	Hybrid	
2	1	ALL	<input checked="" type="checkbox"/> Enabled	Hybrid	
3	1	ALL	<input checked="" type="checkbox"/> Enabled	Hybrid	
4	1	ALL	<input checked="" type="checkbox"/> Enabled	Hybrid	
5	1	ALL	<input checked="" type="checkbox"/> Enabled	Hybrid	
6	1	ALL	<input checked="" type="checkbox"/> Enabled	Hybrid	
7	1	ALL	<input checked="" type="checkbox"/> Enabled	Hybrid	
8	1	ALL	<input checked="" type="checkbox"/> Enabled	Hybrid	

Figure 3-101 Configuring VLANs per Port

CLI – This example sets port 3 to accept only tagged frames, assigns PVID 3 as the native VLAN ID, enables GVRP, sets the GARP timers, and then sets the switchport mode to hybrid.

```
Console(config)#interface ethernet 1/3                4-166
Console(config-if)#switchport acceptable-frame-types tagged 4-246
Console(config-if)#switchport ingress-filtering       4-246
Console(config-if)#switchport native vlan 3          4-247
Console(config-if)#switchport gvrp                  4-240
Console(config-if)#garp timer join 20                4-241
Console(config-if)#garp timer leave 90
Console(config-if)#garp timer leaveall 2000
Console(config-if)#switchport mode hybrid           4-245
Console(config-if)#
```

Configuring IEEE 802.1Q Tunneling

IEEE 802.1Q Tunneling (QinQ) is designed for service providers carrying traffic for multiple customers across their networks. QinQ tunneling is used to maintain customer-specific VLAN and Layer 2 protocol configurations even when different customers use the same internal VLAN IDs. This is accomplished by inserting Service Provider VLAN (SPVLAN) tags into the customer's frames when they enter the service provider's network, and then stripping the tags when the frames leave the network.

A service provider's customers may have specific requirements for their internal VLAN IDs and number of VLANs supported. VLAN ranges required by different customers in the same service-provider network might easily overlap, and traffic passing through the infrastructure might be mixed. Assigning a unique range of VLAN IDs to each customer would restrict customer configurations, require intensive processing of VLAN mapping tables, and could easily exceed the maximum VLAN limit of 4096.

QinQ tunneling uses a single Service Provider VLAN (SPVLAN) for customers who have multiple VLANs. Customer VLAN IDs are preserved and traffic from different customers is segregated within the service provider's network even when they use the same customer-specific VLAN IDs. QinQ tunneling expands VLAN space by using a VLAN-in-VLAN hierarchy, preserving the customer's original tagged packets, and adding SPVLAN tags to each frame (also called double tagging).

A port configured to support QinQ tunneling must be set to tunnel port mode. The Service Provider VLAN (SPVLAN) ID for the specific customer must be assigned to the QinQ tunnel access port on the edge switch where the customer traffic enters the service provider's network. Each customer requires a separate SPVLAN, but this VLAN supports all of the customer's internal VLANs. The QinQ tunnel uplink port that passes traffic from the edge switch into the service provider's metro network must also be added to this SPVLAN. The uplink port can be added to multiple SPVLANs to carry inbound traffic for different customers onto the service provider's network.

When a double-tagged packet enters another trunk port in an intermediate or core switch in the service provider's network, the outer tag is stripped for packet

3 Configuring the Switch

processing. When the packet exits another trunk port on the same core switch, the same SPVLAN tag is again added to the packet.

When a packet enters the trunk port on the service provider's egress switch, the outer tag is again stripped for packet processing. However, the SPVLAN tag is not added when it is sent out the tunnel access port on the edge switch into the customer's network. The packet is sent as a normal IEEE 802.1Q-tagged frame, preserving the original VLAN numbers used in the customer's network.

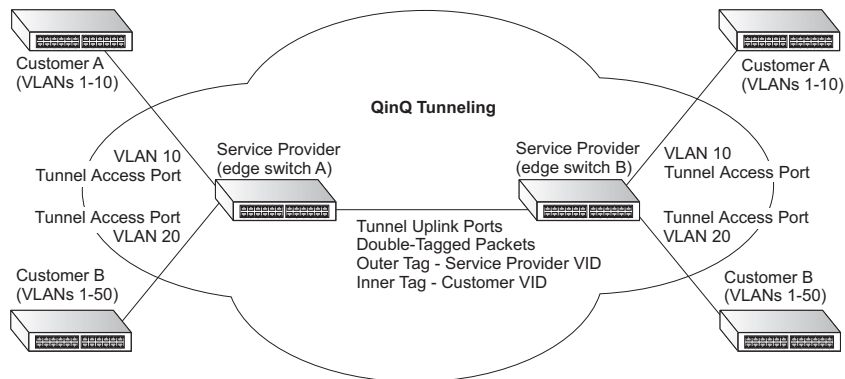

Layer 2 Flow for Packets Coming into a Tunnel Access Port

A QinQ tunnel port may receive either tagged or untagged packets. No matter how many tags the incoming packet has, it is treated as tagged packet.

The ingress process does source and destination lookups. If both lookups are successful, the ingress process writes the packet to memory. Then the egress process transmits the packet. Packets entering a QinQ tunnel port are processed in the following manner:

1. New SPVLAN tags are added to all incoming packets, no matter how many tags they already have. The ingress process constructs and inserts the outer tag (SPVLAN) into the packet based on the default VLAN ID and Tag Protocol Identifier (TPID, that is, the ether-type of the tag). This outer tag is used for learning and switching packets. The priority of the inner tag is copied to the outer tag if it is a tagged or priority tagged packet.
2. After successful source and destination lookup, the ingress process sends the packet to the switching process with two tags. If the incoming packet is untagged, the outer tag is an SPVLAN tag, and the inner tag is a dummy tag (8100 0000). If the incoming packet is tagged, the outer tag is an SPVLAN tag, and the inner tag is a CVLAN tag.
3. After packet classification through the switching process, the packet is written to memory with one tag (an outer tag) or with two tags (both an outer tag and inner tag).
4. The switch sends the packet to the proper egress port.

5. If the egress port is an untagged member of the SPVLAN, the outer tag will be stripped. If it is a tagged member, the outgoing packets will have two tags.

Layer 2 Flow for Packets Coming into a Tunnel Uplink Port

An uplink port receives one of the following packets:

- Untagged
- One tag (CVLAN or SPVLAN)
- Double tag (CVLAN + SPVLAN)

The ingress process does source and destination lookups. If both lookups are successful, the ingress process writes the packet to memory. Then the egress process transmits the packet. Packets entering a QinQ uplink port are processed in the following manner:

1. If incoming packets are untagged, the PVID VLAN native tag is added.
2. If the ether-type of an incoming packet (single or double tagged) is not equal to the TPID of the uplink port, the VLAN tag is determined to be a Customer VLAN (CVLAN) tag. The uplink port's PVID VLAN native tag is added to the packet. This outer tag is used for learning and switching packets within the service provider's network. The TPID must be configured on a per port basis, and the verification cannot be disabled.
3. If the ether-type of an incoming packet (single or double tagged) is equal to the TPID of the uplink port, no new VLAN tag is added. If the uplink port is not the member of the outer VLAN of the incoming packets, the packet will be dropped when ingress filtering is enabled. If ingress filtering is not enabled, the packet will still be forwarded. If the VLAN is not listed in the VLAN table, the packet will be dropped.
4. After successful source and destination lookups, the packet is double tagged. The switch uses the TPID of 0x8100 to indicate that an incoming packet is double-tagged. If the outer tag of an incoming double-tagged packet is equal to the port TPID and the inner tag is 0x8100, it is treated as a double-tagged packet. If a single-tagged packet has 0x8100 as its TPID, and port TPID is not 0x8100, a new VLAN tag is added and it is also treated as double-tagged packet.
5. If the destination address lookup fails, the packet is sent to all member ports of the outer tag's VLAN.
6. After packet classification, the packet is written to memory for processing as a single-tagged or double-tagged packet.
7. The switch sends the packet to the proper egress port.
8. If the egress port is an untagged member of the SPVLAN, the outer tag will be stripped. If it is a tagged member, the outgoing packet will have two tags.

Configuration Limitations for QinQ

- The native VLAN of uplink ports should not be used as the SPVLAN. If the SPVLAN is the uplink port's native VLAN, the uplink port must be an untagged member of the SPVLAN. Then the outer SPVLAN tag will be stripped when the packets are sent out. Another reason is that it causes non-customer packets to be forwarded to the SPVLAN.
- Static trunk port groups are compatible with QinQ tunnel ports as long as the QinQ configuration is consistent within a trunk port group.
- The native VLAN (VLAN 1) is not normally added to transmitted frames. Avoid using VLAN 1 as an SPVLAN tag for customer traffic to reduce the risk of misconfiguration. Instead, use VLAN 1 as a management VLAN instead of a data VLAN in the service provider network.
- There are some inherent incompatibilities between Layer 2 and Layer 3 switching:
 - Tunnel ports do not support IP Access Control Lists.
 - Layer 3 Quality of Service (QoS) and other QoS features containing Layer 3 information are not supported on tunnel ports.
 - Spanning tree bridge protocol data unit (BPDU) filtering is automatically disabled on a tunnel port.

General Configuration Guidelines for QinQ

1. Configure the switch to QinQ mode (see “Enabling QinQ Tunneling on the Switch” on page 3-172).
2. Set the Tag Protocol Identifier (TPID) value of the tunnel access port. This step is required if the attached client is using a nonstandard 2-byte ethertype to identify 802.1Q tagged frames. The default ethertype value is 0x8100. (See “Adding an Interface to a QinQ Tunnel” on page 3-174.)
3. Create a Service Provider VLAN, also referred to as an SPVLAN (see “Creating VLANs” on page 3-163).
4. Configure the QinQ tunnel access port to 802.1Q Tunnel mode (see “Adding an Interface to a QinQ Tunnel” on page 3-174).
5. Configure the QinQ tunnel access port to join the SPVLAN as an untagged member (see “Adding Static Members to VLANs (VLAN Index)” on page 3-164).
6. Configure the SPVLAN ID as the native VID on the QinQ tunnel access port (see “Configuring VLAN Behavior for Interfaces” on page 3-167).
7. Configure the QinQ tunnel uplink port to 802.1Q Tunnel Uplink mode (see “Adding an Interface to a QinQ Tunnel” on page 3-174).
8. Configure the QinQ tunnel uplink port to join the SPVLAN as a tagged member (see “Adding Static Members to VLANs (VLAN Index)” on page 3-164).

Enabling QinQ Tunneling on the Switch

The switch can be configured to operate in normal VLAN mode or IEEE 802.1Q (QinQ) tunneling mode which is used for passing Layer 2 traffic across a service provider's metropolitan area network. You can also globally set the Tag Protocol

Identifier (TPID) value of the tunnel port if the attached client is using a nonstandard 2-byte ethertype to identify 802.1Q tagged frames.

Command Usage

- Use the TPID field to set a custom 802.1Q ethertype value on the selected interface. This feature allows the switch to interoperate with third-party switches that do not use the standard 0x8100 ethertype to identify 802.1Q-tagged frames. For example, if 0x1234 is set as the custom 802.1Q ethertype on a trunk port, incoming frames containing that ethertype are assigned to the VLAN contained in the tag following the ethertype field, as they would be with a standard 802.1Q trunk. Frames arriving on the port containing any other ethertype are looked upon as untagged frames, and assigned to the native VLAN of that port.
- All ports on the switch will be set to the same ethertype.

Command Attributes

- **802.1Q Tunnel** – Sets the switch to QinQ mode, sets the 802.1Q Ethernet Type (TPID), and allows the QinQ tunnel port to be configured. The default is for the switch to function in normal mode.
- **802.1Q Ethernet Type** – The Tag Protocol Identifier (TPID) specifies the ethertype of incoming packets on a tunnel port. (Range: hexadecimal 0800-FFFF; Default: 8100)

Web – Click VLAN, 802.1Q VLAN, 802.1Q Tunnel Status. Check the Enabled box, set the TPID of the ports if the client is using a non-standard ethertype to identify 802.1Q tagged frames, and click Apply.

802.1Q Tunnel Configuration	
802.1Q Tunnel Status	<input checked="" type="checkbox"/> Enabled
802.1Q Ethernet Type	8100 (0800-FFFF, hexadecimal value)

Figure 3-102 802.1Q Tunnel Status and Ethernet Type

3 Configuring the Switch

CLI – This example sets the switch to operate in QinQ mode.

```
Console(config)#dot1q-tunnel system-tunnel-control 4-252
Console(config)#exit
Console#show dot1q-tunnel 4-254

Current double-tagged status of the system is Enabled

The dot1q-tunnel mode of the set interface 1/1 is Access mode, TPID is 0x8100.
The dot1q-tunnel mode of the set interface 1/2 is Uplink mode, TPID is 0x8100.
The dot1q-tunnel mode of the set interface 1/3 is Normal mode, TPID is 0x8100.
The dot1q-tunnel mode of the set interface 1/4 is Normal mode, TPID is 0x8100.
The dot1q-tunnel mode of the set interface 1/5 is Normal mode, TPID is 0x8100.
.
.
.
The dot1q-tunnel mode of the set interface 1/24 is Normal mode, TPID is 0x8100.
Console#
```

Adding an Interface to a QinQ Tunnel

Follow the guidelines in the preceding section to set up a QinQ tunnel on the switch. Use the VLAN Port Configuration or VLAN Trunk Configuration screen to set the access port on the edge switch to 802.1Q Tunnel mode.

Command Usage

Use the 802.1Q Tunnel Status screen to set the switch to QinQ mode before configuring a tunnel port (see “Enabling QinQ Tunneling on the Switch” on page 3-172).

Command Attributes

Mode – Set the VLAN membership mode of the port. (Default: None)

- **None** – The port operates in its normal VLAN mode.
- **802.1Q Tunnel** – Configures IEEE 802.1Q tunneling (QinQ) for a client access port to segregate and preserve customer VLAN IDs for traffic crossing the service provider network.
- **802.1Q Tunnel Uplink** – Configures IEEE 802.1Q tunneling (QinQ) for an uplink port to another device within the service provider network.

Web – Click VLAN, 802.1Q VLAN, 802.1Q Tunnel Configuration or Tunnel Trunk Configuration. Set the mode for a tunnel access port to 802.1Q Tunnel and a tunnel uplink port to 802.1Q Tunnel Uplink. Click Apply.

802.1Q Tunnel Port Configuration

Port	Mode	Trunk Member
1	802.1Q Tunnel	
2	802.1Q Tunnel Uplink	
3	None	
4	None	
5	None	
6	None	
7	None	
8	None	
9	None	

Figure 3-103 Tunnel Port Configuration

CLI – This example sets port 1 to tunnel access mode, indicates that the TPID used for 802.1Q tagged frames is 9100 hexadecimal, and sets port 2 to tunnel uplink mode.

```

Console(config)#interface ethernet 1/1                               4-166
Console(config-if)#switchport dot1q-tunnel mode access             4-252
Console(config-if)#switchport dot1q-tunnel tpid 9100              4-253
Console(config-if)#interface ethernet 1/2
Console(config-if)#switchport dot1q-tunnel mode uplink            4-252
Console(config-if)#end
Console#show dot1q-tunnel                                         4-254

Current double-tagged status of the system is Enabled

The dot1q-tunnel mode of the set interface 1/1 is Access mode, TPID is 0x9100.
The dot1q-tunnel mode of the set interface 1/2 is Uplink mode, TPID is 0x8100.
The dot1q-tunnel mode of the set interface 1/3 is Normal mode, TPID is 0x8100.
The dot1q-tunnel mode of the set interface 1/4 is Normal mode, TPID is 0x8100.
The dot1q-tunnel mode of the set interface 1/5 is Normal mode, TPID is 0x8100.
The dot1q-tunnel mode of the set interface 1/6 is Normal mode, TPID is 0x8100.
The dot1q-tunnel mode of the set interface 1/7 is Normal mode, TPID is 0x8100.
.
.
.
The dot1q-tunnel mode of the set interface 1/24 is Normal mode, TPID is 0x8100.
Console#

```

Private VLANs

Private VLANs provide port-based security and isolation between ports within the assigned VLAN. This switch supports two types of private VLANs: primary/secondary associated groups, and stand-alone isolated VLANs. A primary VLAN

3 Configuring the Switch

contains promiscuous ports that can communicate with all other ports in the private VLAN group, while a secondary (or community) VLAN contains community ports that can only communicate with other hosts within the secondary VLAN and with any of the promiscuous ports in the associated primary VLAN. Isolated VLANs, on the other hand, consist a single stand-alone VLAN that contains one promiscuous port and one or more isolated (or host) ports. In all cases, the promiscuous ports are designed to provide open access to an external network such as the Internet, while the community or isolated ports provide restricted access to local users.

Multiple primary VLANs can be configured on this switch, and multiple community VLANs can be associated with each primary VLAN. One or more isolated VLANs can also be configured. (Note that private VLANs and normal VLANs can exist simultaneously within the same switch.)

To configure primary/secondary associated groups, follow these steps:

1. Use the Private VLAN Configuration menu (page 3-177) to designate one or more community VLANs, and the primary VLAN that will channel traffic outside of the VLAN groups.
2. Use the Private VLAN Association menu (page 3-178) to map the secondary (i.e., community) VLAN(s) to the primary VLAN.
3. Use the Private VLAN Port Configuration menu (page 3-180) to set the port type to promiscuous (i.e., having access to all ports in the primary VLAN), or host (i.e., having access restricted to community VLAN members, and channeling all other traffic through promiscuous ports). Then assign any promiscuous ports to a primary VLAN and any host ports a community VLAN.

To configure an isolated VLAN, follow these steps:

1. Use the Private VLAN Configuration menu (page 3-177) to designate an isolated VLAN that will channel all traffic through a single promiscuous port.
2. Use the Private VLAN Port Configuration menu (page 3-180) to set the port type to promiscuous (i.e., the single channel to the external network), or isolated (i.e., having access only to the promiscuous port in its own VLAN). Then assign the promiscuous port and all host ports to an isolated VLAN.

Displaying Current Private VLANs

The Private VLAN Information page displays information on the private VLANs configured on the switch, including primary, community, and isolated VLANs, and their assigned interfaces.

Command Attributes

- **VLAN ID** – ID of configured VLAN (1-4092), and VLAN type.
- **Primary VLAN** – The VLAN with which the selected VLAN ID is associated. A primary VLAN displays its own ID, a community VLAN displays the associated primary VLAN, and an isolated VLAN displays the stand-alone VLAN.
- **Ports List** – The list of ports (and assigned port type) in the selected private VLAN.

Web – Click VLAN, Private VLAN, Information. Select the desired port from the VLAN ID drop-down menu.

Private VLAN Information

VLAN ID: ▼

Ports List

Unit 1, Port 3, Promiscuous
 Unit 1, Port 4, Host
 Unit 1, Port 5, Host

Figure 3-104 Private VLAN Information

CLI – This example shows the switch configured with primary VLAN 5 and secondary VLAN 6. Port 3 has been configured as a promiscuous port and mapped to VLAN 5, while ports 4 and 5 have been configured as a host ports and are associated with VLAN 6. This means that traffic for port 4 and 5 can only pass through port 3.

```

Console#show vlan private-vlan                                     4-153
Primary      Secondary      Type      Interfaces
-----
5            5              primary   Eth1/ 3
5            6              community Eth1/ 4 Eth1/ 5
  
```

Configuring Private VLANs

The Private VLAN Configuration page is used to create/remove primary, community, or isolated VLANs.

Command Attributes

- **VLAN ID** – ID of configured VLAN (2-4092).
- **Type** – There are three types of private VLANs:
 - **Primary VLANs** – Conveys traffic between promiscuous ports, and to community ports within secondary (or community) VLANs.
 - **Community VLANs** - Conveys traffic between community ports, and to their promiscuous ports in the associated primary VLAN.
- **Current** – Displays a list of the currently configured VLANs.

3 Configuring the Switch

Web – Click VLAN, Private VLAN, Configuration. Enter the VLAN ID number, select Primary, Isolated or Community type, then click Add. To remove a private VLAN from the switch, highlight an entry in the Current list box and then click Remove. Note that all member ports must be removed from the VLAN before it can be deleted.

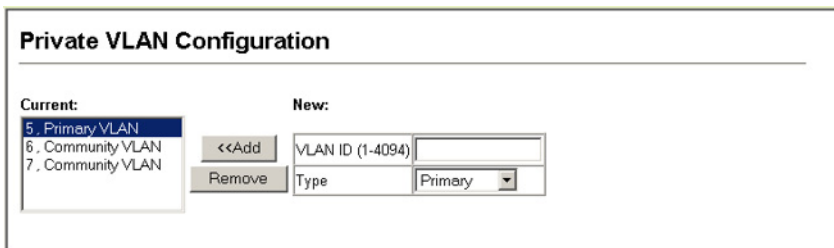

The screenshot shows the 'Private VLAN Configuration' window. On the left, under 'Current:', there is a list box containing three entries: '5, Primary VLAN' (highlighted), '6, Community VLAN', and '7, Community VLAN'. Below this list are 'Remove' and '<<Add' buttons. On the right, under 'New:', there is a 'VLAN ID (1-4094)' input field, a 'Type' dropdown menu set to 'Primary', and an 'Add' button.

Figure 3-105 Private VLAN Configuration

CLI – This example configures VLAN 5 as a primary VLAN, and VLAN 6 as a community VLAN.

```
Console (config)#vlan database 4-242
Console (config-vlan)#private-vlan 5 primary 4-256
Console (config-vlan)#private-vlan 6 community
Console (config-vlan)#
```

Associating VLANs

Each community VLAN must be associated with a primary VLAN.

Command Attributes

- **Primary VLAN ID** – ID of primary VLAN (2-4092).
- **Association** – Community VLANs associated with the selected primary VLAN.
- **Non-Association** – Community VLANs not associated with the selected VLAN.

Web – Click VLAN, Private VLAN, Association. Select the required primary VLAN from the scroll-down box, highlight one or more community VLANs in the Non-Association list box, and click Add to associate these entries with the selected primary VLAN. (A community VLAN can only be associated with one primary VLAN.)

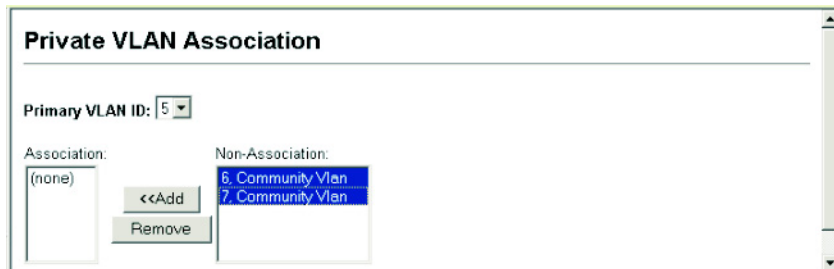

The screenshot shows the 'Private VLAN Association' window. At the top, 'Primary VLAN ID:' is set to '5'. Below this, there are two list boxes: 'Association:' containing '(none)' and 'Non-Association:' containing '6, Community Vlan' and '7, Community Vlan' (both highlighted). Between the list boxes are '<<Add' and 'Remove' buttons.

Figure 3-106 Private VLAN Association

CLI – This example associates community VLANs 6 and 7 with primary VLAN 5.

```

Console(config)#vlan database                               4-242
Console(config-vlan)#private-vlan 5 association 6          4-256
Console(config-vlan)#private-vlan 5 association 7          4-256
Console(config)#
  
```

Displaying Private VLAN Interface Information

Use the Private VLAN Port Information and Private VLAN Trunk Information menus to display the interfaces associated with private VLANs.

Command Attributes

- **Port/Trunk** – The switch interface.
- **PVLAN Port Type** – Displays private VLAN port types.
 - **Normal** – The port is not configured in a private VLAN.
 - **Host** – The port is a community port and can only communicate with other ports in its own community VLAN, and with the designated promiscuous port(s). Or the port is an isolated port that can only communicate with the lone promiscuous port within its own isolated VLAN.
 - **Promiscuous** – A promiscuous port can communicate with all the interfaces within a private VLAN.
- **Primary VLAN** – Conveys traffic between promiscuous ports, and between promiscuous ports and community ports within the associated secondary VLANs.
- **Community VLAN** – A community VLAN conveys traffic between community ports, and from community ports to their designated promiscuous ports.
- **Trunk** – The trunk identifier. (Port Information only)

Web – Click VLAN, Private VLAN, Port Information or Trunk Information.

Port	PVLAN Port Type	Primary VLAN	Community VLAN	Trunk
1	Normal			
2	Normal			
3	Normal			
4	Normal			
5	Normal			
6	Normal			
7	Normal			
8	Normal			
9	Normal			
10	Normal			

Figure 3-107 Private VLAN Port Information

3 Configuring the Switch

CLI – This example shows the switch configured with primary VLAN 5 and community VLAN 6. Port 3 has been configured as a promiscuous port and mapped to VLAN 5, while ports 4 and 5 have been configured as host ports and associated with VLAN 6. This means that traffic for port 4 and 5 can only pass through port 3.

```
Console#show vlan private-vlan 4-259
Primary   Secondary   Type           Interfaces
-----
          5           primary        Eth1/ 3
          5           6             community      Eth1/ 4 Eth1/ 5
Console#
```

Configuring Private VLAN Interfaces

Use the Private VLAN Port Configuration and Private VLAN Trunk Configuration menus to set the private VLAN interface type, and assign the interfaces to a private VLAN.

Command Attributes

- **Port/Trunk** – The switch interface.
- **PVLAN Port Type** – Sets the private VLAN port types.
 - **Normal** – The port is not assigned to a private VLAN.
 - **Host** – The port is a community port or an isolated port. A community port can communicate with other ports in its own community VLAN and with designated promiscuous port(s). An isolated port can only communicate with the single designated promiscuous port in the isolated VLAN; it cannot communicate with any other host ports.
 - **Promiscuous** – A promiscuous port can communicate with all interfaces within a private VLAN.
- **Primary VLAN** – Conveys traffic between promiscuous ports, and between promiscuous ports and community ports within the associated secondary VLANs. If PVLAN type is “Promiscuous,” then specify the associated primary VLAN.
- **Community VLAN** – A community VLAN conveys traffic between community ports, and from community ports to their designated promiscuous ports. Set PVLAN Port Type to “Host,” and then specify the associated Community VLAN.
- **Trunk** – The trunk identifier. (Port Information only)

Web – Click VLAN, Private VLAN, Port Configuration or Trunk Configuration. Set the PVLAN Port Type for each port that will join a private VLAN. Assign promiscuous ports to a primary VLAN. Assign host ports to a community VLAN. After all the ports have been configured, click Apply.

Private VLAN Port Configuration				
Port	PVLAN Port Type	Primary VLAN	Community VLAN	Trunk
1	Normal	(none)	(none)	
2	Normal	(none)	(none)	
3	Normal	(none)	(none)	
4	Normal	(none)	(none)	
5	Normal	(none)	(none)	
6	Normal	(none)	(none)	
7	Normal	(none)	(none)	
8	Normal	(none)	(none)	

Figure 3-108 Private VLAN Port Configuration

CLI – This example shows the switch configured with primary VLAN 5 and secondary VLAN 6. Port 3 has been configured as a promiscuous port and mapped to VLAN 5, while ports 4 and 5 have been configured as a host ports and associated with VLAN 6. This means that traffic for port 4 and 5 can only pass through port 3.

```

Console(config)#interface ethernet 1/3
Console(config-if)#switchport mode private-vlan promiscuous           4-257
Console(config-if)#switchport private-vlan mapping 5                 4-259
Console(config-if)#exit
Console(config)#interface ethernet 1/4
Console(config-if)#switchport mode private-vlan host                 4-257
Console(config-if)#switchport private-vlan host-association 6       4-258
Console(config-if)#exit
Console(config)#interface ethernet 1/5
Console(config-if)#switchport mode private-vlan host
Console(config-if)#switchport private-vlan host-association 6
Console(config-if)#

```

Protocol VLANs

You can configure VLAN behavior to support multiple protocols to allow traffic to pass through different VLANs. When a packet is received at a port, its VLAN membership is determined by the protocol type of the packet.

Protocol VLAN Group Configuration

Command Attributes

- **Protocol Group ID** – Protocol Group ID assigned to the Protocol VLAN Group. (Range: 1-2147483647)

3 Configuring the Switch

- **Frame Type** – Choose either Ethernet, RFC 1042, or LLC Other as the frame type used by this protocol.
- **Protocol Type** – Specifies the protocol type to match. The available options are IP, ARP, and RARP. If LLC Other is chosen for the Frame Type, the only available Protocol Type is IPX Raw

Note: Traffic which matches IP Protocol Ethernet Frames is mapped to the VLAN (VLAN 1) that has been configured with the switch's administrative IP. IP Protocol Ethernet traffic must not be mapped to another VLAN or you will lose administrative network connectivity to the switch. If lost in this manner, network access can be regained by removing the offending Protocol VLAN rule via the console. Alternately, the switch can be power-cycled, however all unsaved configuration changes will be lost.

Web – Click VLAN, Protocol VLAN, Configuration.

Current:	New:
(none)	Protocol Group ID (1-2147483647) <input type="text" value="1-2147483647"/>
<<Add Remove	Frame Type <input type="text" value="Ethernet"/>
	Protocol Type <input type="text" value="IP"/>

Figure 3-109 Protocol VLAN Configuration

CLI – This example shows the switch configured with Protocol Group 2 which matches RFC 1042 IP traffic.

```
Console(config)#protocol-vlan protocol group 2 add frame-type  
rfc-1042 protocol-type ip  
Console(config)#
```

4-261

Protocol VLAN System Configuration

Use the Protocol VLAN System Configuration menu to map a Protocol VLAN Group to a VLAN.

Command Attributes

- **Protocol Group ID** – Protocol Group ID assigned to the Protocol VLAN Group. (Range: 1-2147483647)
- **VLAN ID** – VLAN to which matching protocol traffic is forwarded. (Range: 1-4092)

Web – Click VLAN, Protocol VLAN, System Configuration.

Protocol VLAN System Configuration

Current:

- Group 2, VLAN 2

New:

Protocol Group ID (1-2147483647)	<input type="text"/>
VLAN ID (1-4092)	<input type="text"/>

Buttons: <<Add, Remove

Figure 3-110 Protocol VLAN System Configuration

CLI – This example shows the switch configured with Protocol Group 2 mapped to VLAN 2.

```
Console (config)#protocol-vlan protocol-group 2 vlan 2          4-262
Console (config)#
```

Link Layer Discovery Protocol

Link Layer Discovery Protocol (LLDP) is used to discover basic information about neighboring devices on the local broadcast domain. LLDP is a Layer 2 protocol that uses periodic broadcasts to advertise information about the sending device. Advertised information is represented in Type Length Value (TLV) format according to the IEEE 802.1ab standard, and can include details such as device identification, capabilities and configuration settings. LLDP also defines how to store and maintain information gathered about the neighboring network nodes it discovers.

Link Layer Discovery Protocol - Media Endpoint Discovery (LLDP-MED) is an extension of LLDP intended for managing endpoint devices such as Voice over IP phones and network switches. The LLDP-MED TLVs advertise information such as network policy, power, inventory, and device location details. The LLDP and LLDP-MED information can be used by SNMP applications to simplify troubleshooting, enhance network management, and maintain an accurate network topology.

Setting LLDP Timing Attributes

Use the LLDP Configuration screen to set attributes for general functions such as globally enabling LLDP on the switch, setting the message ageout time, and setting the frequency for broadcasting general advertisements or reports about changes in the LLDP MIB.

Command Attributes

- **LLDP** – Enables LLDP globally on the switch. (Default: Enabled)
- **Transmission Interval** – Configures the periodic transmit interval for LLDP advertisements. (Range: 5-32768 seconds; Default: 30 seconds)
This attribute must comply with the following rule:
 $(\text{transmission-interval} * \text{holdtime-multiplier}) \leq 65536$
- **Hold Time Multiplier** – Configures the time-to-live (TTL) value sent in LLDP advertisements as shown in the formula below. (Range: 2-10; Default: 4)
The time-to-live tells the receiving LLDP agent how long to retain all information pertaining to the sending LLDP agent if it does not transmit updates in a timely manner. TTL in seconds is based on $(\text{refresh-interval} * \text{holdtime-multiplier}) \leq 65536$
Therefore, the default TTL is $4 * 30 = 120$ seconds.
- **Delay Interval** – Configures a delay between the successive transmission of advertisements initiated by a change in local LLDP MIB variables. (Range: 1-8192 seconds; Default: 2 seconds)
The transmit delay is used to prevent a series of successive LLDP transmissions during a short period of rapid changes in local LLDP MIB objects, and to increase the probability that multiple, rather than single changes, are reported in each transmission.
This attribute must comply with the rule: $(4 * \text{delay-interval}) \leq \text{transmission-interval}$
- **Reinitialization Delay** – Configures the delay before attempting to re-initialize after LLDP ports are disabled or the link goes down. (Range: 1-10 seconds; Default: 2 seconds)
When LLDP is re-initialized on a port, all information in the remote systems LLDP MIB associated with this port is deleted.
- **Notification Interval** – Configures the allowed interval for sending SNMP notifications about LLDP MIB changes. (Range: 5-3600 seconds; Default: 5 seconds)
This parameter only applies to SNMP applications which use data stored in the LLDP MIB for network monitoring or management.
Information about changes in LLDP neighbors that occur between SNMP notifications is not transmitted. Only state changes that exist at the time of a notification are included in the transmission. An SNMP agent should therefore periodically check the value of `IldpStatsRemTableLastChangeTime` to detect any `IldpRemTablesChange` notification-events missed due to throttling or transmission loss.
- **MED Fast Start Count** – Configures the amount of LLDP MED Fast Start LLDPDUs to transmit during the activation process of the LLDP-MED Fast Start mechanism. (Range: 1-10 packets; Default: 4 packets)
The MED Fast Start Count parameter is part of the timer which ensures that the LLDP-MED Fast Start mechanism is active for the port. LLDP-MED Fast Start is

critical to the timely startup of LLDP, and therefore integral to the rapid availability of Emergency Call Service.

Web – Click LLDP, Configuration. Enable LLDP, modify any of the timing parameters as required, and click Apply.

LLDP Configuration

LLDP	<input type="checkbox"/> Enabled	
Transmission Interval (5-32768)	30	seconds
Hold time Multiplier (2-10)	4	
Delay Interval (1-8192)	2	seconds
Reinitialization Delay (1-10)	2	seconds
Notification Interval (5-3600)	5	seconds
MED Fast Start Count (1-10)	4	counts

Note: The Transmission Interval must be greater than or equal to 4 times delay interval.

Figure 3-111 LLDP Configuration

CLI – This example sets several attributes which control basic LLDP message timing.

```

Console(config)#lldp                               4-195
Console(config)#lldp refresh-interval 60           4-197
Console(config)#lldp holdtime-multiplier 10        4-195
Console(config)#lldp tx-delay 10                   4-198
Console(config)#lldp reinit-delay 10                4-198
Console(config)#lldp notification-interval 30      4-196
Console(config)#lldp medFastStartCount 6           4-196
Console(config)#exit
Console#show lldp config

LLDP Global Configuration

  LLDP Enable                : Yes
  LLDP Transmit interval     : 60
  LLDP Hold Time Multiplier  : 10
  LLDP Delay Interval        : 10
  LLDP Reinit Delay         : 10
  LLDP Notification Interval : 30
  :
```

Configuring LLDP Interface Attributes

Use the LLDP Port/Trunk Configuration to specify the message attributes for individual interfaces, including whether messages are transmitted, received, or both transmitted and received, whether SNMP notifications are sent, and the type of information advertised.

Command Attributes

- **Admin Status** – Enables LLDP message transmit and receive modes for LLDP Protocol Data Units. (Options: Tx only, Rx only, TxRx, Disabled; Default: TxRx)
- **SNMP Notification** – Enables the transmission of SNMP trap notifications about LLDP and LLDP-MED changes. (Default: Enabled)

This option sends out SNMP trap notifications to designated target stations at the interval specified by the Notification Interval in the preceding section. Trap notifications include information about state changes in the LLDP MIB (IEEE 802.1AB), the LLDP-MED MIB (ANSI/TIA-1057), or vendor-specific LLDP-EXT-DOT1 and LLDP-EXT-DOT3 MIBs.

For information on defining SNMP trap destinations, see “Specifying Trap Managers and Trap Types” on page 3-40.

Information about additional changes in LLDP neighbors that occur between SNMP notifications is not transmitted. Only state changes that exist at the time of a trap notification are included in the transmission. An SNMP agent should therefore periodically check the value of `IldpStatsRemTableLastChangeTime` to detect any `IldpRemTablesChange` notification-events missed due to throttling or transmission loss.

- **TLV Type** – Configures the information included in the TLV field of advertised messages.
 - **Port Description** – The port description is taken from the `ifDescr` object in RFC 2863, which includes information about the manufacturer, the product name, and the version of the interface hardware/software.
 - **System Description** – The system description is taken from the `sysDescr` object in RFC 3418, which includes the full name and version identification of the system's hardware type, software operating system, and networking software.
 - **Management Address** – The management address protocol packet includes the IPv4 address of the switch. If no management address is available, the address should be the MAC address for the CPU or for the port sending this advertisement.

The management address TLV may also include information about the specific interface associated with this address, and an object identifier indicating the type of hardware component or protocol entity associated with this address. The interface number and OID are included to assist SNMP applications in the performance of network discovery by indicating enterprise specific or other starting points for the search, such as the Interface or Entity MIB.

Since there are typically a number of different addresses associated with a Layer 3 device, an individual LLDP PDU may contain more than one management address TLV.

Every management address TLV that reports an address that is accessible on a port and protocol VLAN through the particular port should be accompanied by a port and protocol VLAN TLV that indicates the VLAN identifier (VID) associated with the management address reported by this TLV.

- **System Name** – The system name is taken from the `sysName` object in RFC 3418, which contains the system's administratively assigned name. To

configure the system name, see “Displaying System Information” on page 3-12.

- **System Capabilities** – The system capabilities identifies the primary function(s) of the system and whether or not these primary functions are enabled. The information advertised by this TLV is described in IEEE 802.1AB.
- **MED TLV Type** – Configures the information included in the MED TLV field of advertised messages.
 - **Port Capabilities** – This option advertises LLDP-MED TLV capabilities, allowing Media Endpoint and Connectivity Devices to efficiently discover which LLDP-MED related TLVs are supported on the switch.
 - **Network Policy** – This option advertises network policy configuration information, aiding in the discovery and diagnosis of VLAN configuration mismatches on a port. Improper network policy configurations frequently result in voice quality degradation or complete service disruption.
 - **Location** – This option advertises location identification details.
 - **Extended Power** – This option advertises extended Power-over-Ethernet capability details, such as power availability from the switch, and power state of the switch, including whether the switch is operating from primary or backup power (the Endpoint Device could use this information to decide to enter power conservation mode). Note that this device does not support PoE capabilities.
 - **Inventory** – This option advertises device details useful for inventory management, such as manufacturer, model, software version and other pertinent information.
- **MED Notification** – Enables the transmission of SNMP trap notifications about LLDP-MED changes. (Default: Enabled)
- **Trunk** – The trunk identifier. (Port Information only)

Web – Click LLDP, Port/Trunk Configuration. Set the LLDP transmit/receive mode, specify whether or not to send SNMP trap messages, select the information to advertise in LLDP messages, select the information to advertise in MED-TLV messages and specify whether or not to send MED notifications. Then click Apply.

LLDP Port Configuration								
Port	Admin Status	SNMP Notification	TLV Type		MED TLV Type		MED Notification	Trunk
1	Tx/Rx	<input checked="" type="checkbox"/> Enabled	<input checked="" type="checkbox"/> Port Description <input checked="" type="checkbox"/> System Description <input checked="" type="checkbox"/> Management Address	<input checked="" type="checkbox"/> System Name <input checked="" type="checkbox"/> System Capabilities	<input checked="" type="checkbox"/> Port Capabilities <input checked="" type="checkbox"/> Network Policy <input checked="" type="checkbox"/> Location	<input checked="" type="checkbox"/> Extended Power <input checked="" type="checkbox"/> Inventory	<input checked="" type="checkbox"/> Enabled	
2	Tx/Rx	<input checked="" type="checkbox"/> Enabled	<input checked="" type="checkbox"/> Port Description <input checked="" type="checkbox"/> System Description <input checked="" type="checkbox"/> Management Address	<input checked="" type="checkbox"/> System Name <input checked="" type="checkbox"/> System Capabilities	<input checked="" type="checkbox"/> Port Capabilities <input checked="" type="checkbox"/> Network Policy <input checked="" type="checkbox"/> Location	<input checked="" type="checkbox"/> Extended Power <input checked="" type="checkbox"/> Inventory	<input checked="" type="checkbox"/> Enabled	
3	Tx only	<input type="checkbox"/> Enabled	<input type="checkbox"/> Port Description <input type="checkbox"/> System Description <input type="checkbox"/> Management Address	<input type="checkbox"/> System Name <input type="checkbox"/> System Capabilities	<input checked="" type="checkbox"/> Port Capabilities <input checked="" type="checkbox"/> Network Policy <input checked="" type="checkbox"/> Location	<input type="checkbox"/> Extended Power <input checked="" type="checkbox"/> Inventory	<input checked="" type="checkbox"/> Enabled	1

Figure 3-112 LLDP Port Configuration

3 Configuring the Switch

CLI – This example sets the interface to both transmit and receive LLDP messages, enables SNMP trap messages, enables MED notification, and specifies the TLV, MED-TLV, dot1-TLV and dot3-TLV parameters to advertise.

```
Console(config)#interface ethernet 1/1 4-166
Console(config-if)#lldp admin-status tx-rx 4-199
Console(config-if)#lldp notification 4-199
Console(config-if)#lldp medNotification 4-200
Console(config-if)#lldp basic-tlv port-description 4-201
Console(config-if)#lldp basic-tlv system-description 4-202
Console(config-if)#lldp basic-tlv management-ip-address 4-201
Console(config-if)#lldp basic-tlv system-name 4-203
Console(config-if)#lldp basic-tlv system-capabilities 4-202
Console(config-if)#lldp medtlv extPoe 4-207
Console(config-if)#lldp medtlv inventory 4-208
Console(config-if)#lldp medtlv location 4-208
Console(config-if)#lldp medtlv med-cap 4-209
Console(config-if)#lldp medtlv network-policy 4-209
Console(config-if)#lldp dot1-tlv proto-ident 4-203
Console(config-if)#lldp dot1-tlv proto-vid 4-204
Console(config-if)#lldp dot1-tlv pvid 4-204
Console(config-if)#lldp dot1-tlv vlan-name 4-205
Console(config-if)#lldp dot3-tlv link-agg 4-205
Console(config-if)#lldp dot3-tlv mac-phy 4-206
Console(config-if)#lldp dot3-tlv max-frame 4-206
Console(config-if)#lldp dot3-tlv poe 4-207
Console(config-if)#
```

Displaying LLDP Local Device Information

Use the LLDP Local Device Information screen to display information about the switch, such as its MAC address, chassis ID, management IP address, and port information.

Web – Click LLDP, Local Information.

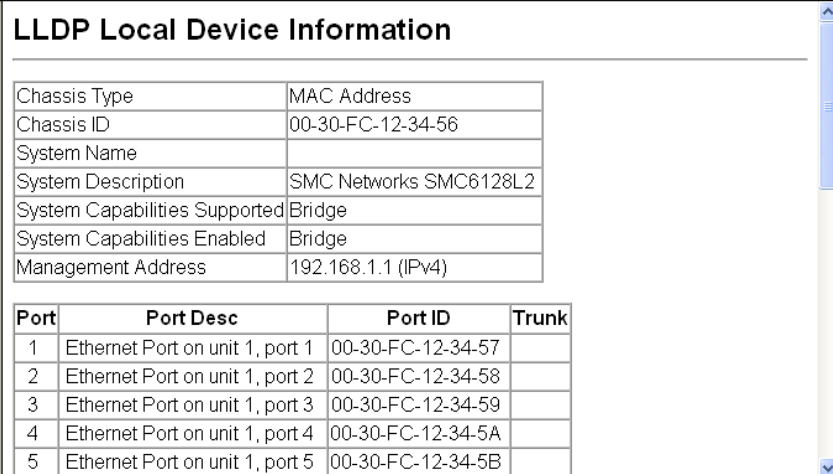

LLDP Local Device Information

Chassis Type	MAC Address
Chassis ID	00-30-FC-12-34-56
System Name	
System Description	SMC Networks SMC6128L2
System Capabilities Supported	Bridge
System Capabilities Enabled	Bridge
Management Address	192.168.1.1 (IPv4)

Port	Port Desc	Port ID	Trunk
1	Ethernet Port on unit 1, port 1	00-30-FC-12-34-57	
2	Ethernet Port on unit 1, port 2	00-30-FC-12-34-58	
3	Ethernet Port on unit 1, port 3	00-30-FC-12-34-59	
4	Ethernet Port on unit 1, port 4	00-30-FC-12-34-5A	
5	Ethernet Port on unit 1, port 5	00-30-FC-12-34-5B	

Figure 3-113 LLDP Local Device Information

CLI – This example displays LLDP information for the local switch.

```

Console#show lldp info local-device 4-212

LLDP Local System Information
Chassis Type : MAC Address
Chassis ID   : 00-01-02-03-04-05
System Name  :
System Description : TL-SL5428
System Capabilities Support : Bridge
System Capabilities Enable : Bridge
Management Address : 192.168.0.101 (IPv4)

LLDP Port Information
Interface |PortID Type          PortID          PortDesc
-----+-----
Eth 1/1  |MAC Address         00-01-02-03-04-06 Ethernet Port on unit 1, port 1
Eth 1/2  |MAC Address         00-01-02-03-04-07 Ethernet Port on unit 1, port 2
Eth 1/3  |MAC Address         00-01-02-03-04-08 Ethernet Port on unit 1, port 3
Eth 1/4  |MAC Address         00-01-02-03-04-09 Ethernet Port on unit 1, port 4
Eth 1/5  |MAC Address         00-01-02-03-04-0A Ethernet Port on unit 1, port 5
:
:
:

```

This example displays detailed information for a specific port on the local switch.

```

Console#show lldp info local-device ethernet 1/1 4-212

LLDP Port Information Detail

Port       : Eth 1/1
Port Type  : MAC Address
Port ID    : 00-01-02-03-04-06
Port Desc  : Ethernet Port on unit 1, port 1

Console#

```

Displaying LLDP Remote Port Information

Use the LLDP Remote Port/Trunk Information screen to display information about devices connected directly to the switch's ports which are advertising information through LLDP.

Web – Click LLDP, Remote Port/Trunk Information.

LLDP Port Remote Device Information				
Local Port	Chassis ID	Port ID	Port Name	System Name
1	00-01-02-03-04-05	00-01-02-03-04-06	Ethernet Port on unit 1, port 1	

Figure 3-114 LLDP Remote Port Information

3 Configuring the Switch

CLI – This example displays LLDP information for remote devices attached to this switch which are advertising information through LLDP.

```
Console#show lldp info remote-device 4-213

LLDP Remote Devices Information

Interface | ChassisId          PortId          SysName
-----+-----
Eth 1/1  | 00-01-02-03-04-05  00-01-02-03-04-06

Console#
```

Displaying LLDP Remote Information Details

Use the LLDP Remote Information Details screen to display detailed information about an LLDP-enabled device connected to a specific port on the local switch.

Web – Click LLDP, Remote Information Details. Select an interface from the drop down lists, and click Query.

LLDP Remote Device Information Detail

Interface Port 1 Trunk

Local Port	1
Chassis Type	MAC Address
Chassis ID	00-01-02-03-04-05
Port Type	MAC Address
Port Description	Ethernet Port on unit 1, port 1
Port ID	00-01-02-03-04-06
System Name	
System Description	ES3528M
System Capabilities Supported	Bridge
System Capabilities Enabled	Bridge
Management Address	192.168.0.101 (IPv4)

Figure 3-115 LLDP Remote Information Details

CLI – This example displays LLDP information for an LLDP-enabled remote device attached to a specific port on this switch.

```

Console#show lldp info remote-device detail ethernet 1/1          4-213

LLDP Remote Devices Information Detail

-----
Local PortName       : Eth 1/1
Chassis Type        : MAC Address
Chassis Id          : 00-01-02-03-04-05
PortID Type         : MAC Address
PortID              : 00-01-02-03-04-06
SysName             :
SysDescr            : TL-SL5428
PortDescr           : Ethernet Port on unit 1, port 1
SystemCapSupported  : Bridge
SystemCapEnabled    : Bridge
Remote Management Address :
    00-01-02-03-04-05 (MAC Address)

Console#

```

Displaying Device Statistics

Use the LLDP Device Statistics screen to display aggregate statistics about all LLDP-enabled device connected to this switch.

Web – Click LLDP, Device Statistics.

LLDP Device Statistics			
Neighbor Entries List Last Updated	75974		
New Neighbor Entries Count	2		
Neighbor Entries Deleted Count	1		
Neighbor Entries Dropped Count	0		
Neighbor Entries Age-out Count	0		
LLDP Port Statistics			
Port	Num Frames Recvd	Num Frames Sent	Num Frames Discarded
1	590	591	0
2	0	0	0
3	0	0	0
4	0	0	0
5	0	0	0

Figure 3-116 LLDP Device Statistics

3 Configuring the Switch

CLI – This example displays LLDP statistics received from all LLDP-enabled remote devices connected directly to this switch.

```
switch#show lldp info statistics 4-213

LLDP Device Statistics

Neighbor Entries List Last Updated : 2450279 seconds
New Neighbor Entries Count          : 1
Neighbor Entries Deleted Count      : 0
Neighbor Entries Dropped Count      : 0
Neighbor Entries Ageout Count       : 0

Interface | NumFramesRecvd NumFramesSent NumFramesDiscarded
-----+-----+-----+-----
Eth 1/1   | 10             11             0
Eth 1/2   | 0              0              0
Eth 1/3   | 0              0              0
Eth 1/4   | 0              0              0
Eth 1/5   | 0              0              0
:
```

Displaying Detailed Device Statistics

Use the LLDP Device Statistics Details screen to display statistics based on traffic received through all attached LLDP-enabled interfaces.

Web – Click LLDP, Device Statistics Details.

LLDP Device Statistics Detail

Interface Port 1 Trunk

Query

Frames Discarded	0
Frames Invalid	0
Frames Received	114
Frames Sent	114
TLVs Unrecognized	0
TLVs Discarded	0
Neighbor Ageouts	0

Refresh

Figure 3-117 LLDP Device Statistics Details

CLI – This example displays detailed LLDP statistics for an LLDP-enabled remote device attached to a specific port on this switch.

```
switch#show lldp info statistics detail ethernet 1/1 4-213

LLDP Port Statistics Detail

PortName           : Eth 1/1
Frames Discarded   : 0
Frames Invalid     : 0
Frames Received    : 12
Frames Sent        : 13
TLVs Unrecognized : 0
TLVs Discarded     : 0
Neighbor Ageouts  : 0

switch#
```

Class of Service Configuration

Class of Service (CoS) allows you to specify which data packets have greater precedence when traffic is buffered in the switch due to congestion. This switch supports CoS with four priority queues for each port. Data packets in a port's high-priority queue will be transmitted before those in the lower-priority queues. You can set the default priority for each interface, and configure the mapping of frame priority tags to the switch's priority queues.

Layer 2 Queue Settings

Setting the Default Priority for Interfaces

You can specify the default port priority for each interface on the switch. All untagged packets entering the switch are tagged with the specified default port priority, and then sorted into the appropriate priority queue at the output port.

Command Usage

- This switch provides four priority queues for each port. It uses Weighted Round Robin to prevent head-of-queue blockage.
- The default priority applies for an untagged frame received on a port set to accept all frame types (i.e., receives both untagged and tagged frames). This priority does not apply to IEEE 802.1Q VLAN tagged frames. If the incoming frame is an IEEE 802.1Q VLAN tagged frame, the IEEE 802.1p User Priority bits will be used.
- If the output port is an untagged member of the associated VLAN, these frames are stripped of all VLAN tags prior to transmission.

3 Configuring the Switch

Command Attributes

- **Default Priority**¹² – The priority that is assigned to untagged frames received on the specified interface. (Range: 0-7; Default: 0)
- **Number of Egress Traffic Classes** – The number of queue buffers provided for each port.

Web – Click Priority, Default Port Priority or Default Trunk Priority. Modify the default priority for any interface, then click Apply.

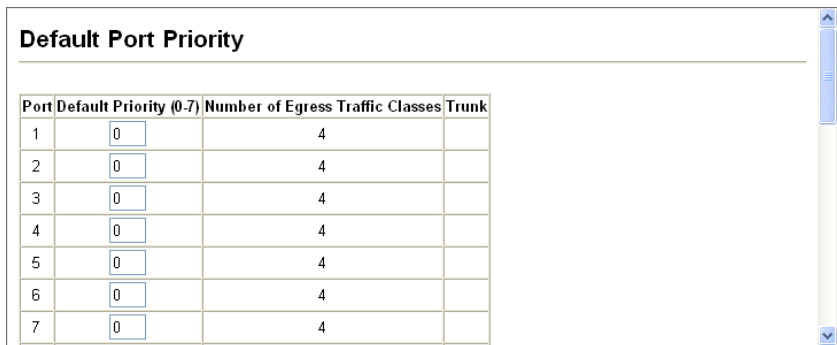

Port	Default Priority (0-7)	Number of Egress Traffic Classes	Trunk
1	0	4	
2	0	4	
3	0	4	
4	0	4	
5	0	4	
6	0	4	
7	0	4	

Figure 3-118 Port Priority Configuration

CLI – This example assigns a default priority of 5 to port 3.

```
Console(config)#interface ethernet 1/3 4-166
Console(config-if)#switchport priority default 5 4-265
Console(config-if)#end
Console#show interfaces switchport ethernet 1/3 4-175
Information of Eth 1/3
Broadcast threshold: Enabled, 500 packets/second
LACP status: Disabled
Ingress rate limit: enable, K bits per second: 25
VLAN membership mode: Hybrid
Ingress rule: Enabled
Acceptable frame type: All frames
Native VLAN: 1
Priority for untagged traffic: 5
GVRP status: Disabled
Allowed VLAN: 1(u),
Forbidden VLAN:
Private-VLAN mode: NONE
Private-VLAN host-association: NONE
Private-VLAN mapping: NONE
Console#
```

Mapping CoS Values to Egress Queues

This switch processes Class of Service (CoS) priority tagged traffic by using four priority queues for each port, with service schedules based on strict or Weighted

12. CLI displays this information as “Priority for untagged traffic.”

Round Robin (WRR). Up to eight separate traffic priorities are defined in IEEE 802.1p. The default priority levels are assigned according to recommendations in the IEEE 802.1p standard as shown in the following table.

Table 3-12 Mapping CoS Values to Egress Queues

Queue	0	1	2	3
Priority	1,2	0,3	4,5	6,7

The priority levels recommended in the IEEE 802.1p standard for various network applications are shown in the following table. However, you can map the priority levels to the switch's output queues in any way that benefits application traffic for your own network.

Table 3-13 CoS Priority Levels

Priority Level	Traffic Type
1	Background
2	(Spare)
0 (default)	Best Effort
3	Excellent Effort
4	Controlled Load
5	Video, less than 100 milliseconds latency and jitter
6	Voice, less than 10 milliseconds latency and jitter
7	Network Control

Command Attributes

- **Priority** – CoS value. (Range: 0-7, where 7 is the highest priority)
- **Traffic Class**¹³ – Output queue buffer. (Range: 0-3, where 3 is the highest CoS priority queue)

13. CLI shows Queue ID.

3 Configuring the Switch

Web – Click Priority, Traffic Classes. The current mapping of CoS values to output queues is displayed. Assign priorities to the traffic classes (i.e., output queues), then click Apply.

Priority	Traffic Class
0	<input type="text" value="1"/> (0-3)
1	<input type="text" value="0"/> (0-3)
2	<input type="text" value="0"/> (0-3)
3	<input type="text" value="1"/> (0-3)
4	<input type="text" value="2"/> (0-3)
5	<input type="text" value="2"/> (0-3)
6	<input type="text" value="3"/> (0-3)
7	<input type="text" value="3"/> (0-3)

Figure 3-119 Traffic Classes

CLI – The following example shows how to change the CoS assignments.

```
Console(config)#interface ethernet 1/1 4-166
Console(config-if)#queue cos-map 0 0 4-267
Console(config-if)#queue cos-map 1 1
Console(config-if)#queue cos-map 2 2
Console(config-if)#end
Console#show queue cos-map ethernet 1/1 4-269
Information of Eth 1/1
CoS Value:      0 1 2 3 4 5 6 7
Priority Queue: 0 1 2 1 2 2 3 3
Console#
```

* Mapping specific values for CoS priorities is implemented as an interface configuration command, but any changes will apply to the all interfaces on the switch.

Enabling CoS

Enable or disable Class of Service (CoS). Command Attributes

- **Traffic Classes** – Click to enable Class of Service. (Default: Enabled)

Web – Click Priority, Traffic Classes Status.

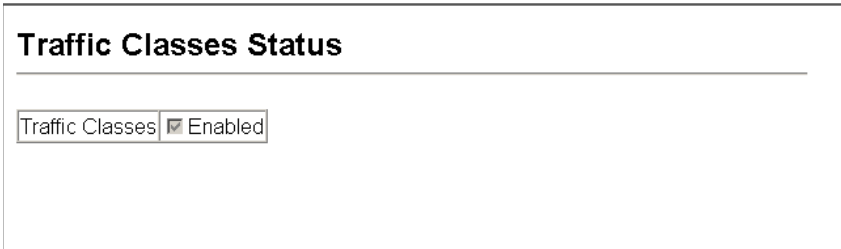

Traffic Classes Status

Traffic Classes Enabled

Figure 3-120 Enable Traffic Classes

Selecting the Queue Mode

You can set the switch to service the queues based on a strict rule that requires all traffic in a higher priority queue to be processed before lower priority queues are serviced, or use Weighted Round-Robin (WRR) queuing that specifies a relative weight of each queue. WRR uses a predefined relative weight for each queue that determines the percentage of service time the switch services each queue before moving on to the next queue. This prevents the head-of-line blocking that can occur with strict priority queuing.

Command Attributes

- **WRR** - Weighted Round-Robin shares bandwidth at the egress ports by using scheduling weights 1, 2, 4, 8, for queues 0 through 3 respectively. (This is the default selection.)
- **Strict** - Services the egress queues in sequential order, transmitting all traffic in the higher priority queues before servicing lower priority queues.

Web – Click Priority, Queue Mode. Select Strict or WRR, then click Apply.



Queue Mode

Queue Mode WRR

Figure 3-121 Queue Mode

CLI – The following sets the queue mode to strict priority service mode.

```

Console(config)#queue mode wrr                               4-265
Console(config)#exit
Console#show queue mode                                     4-268
Queue mode: wrr
Console#

```

Setting the Service Weight for Traffic Classes

This switch uses the Weighted Round Robin (WRR) algorithm to determine the frequency at which it services each priority queue. As described in “Mapping CoS

3 Configuring the Switch

Values to Egress Queues” on page 3-194, the traffic classes are mapped to one of the eight egress queues provided for each port. You can assign a weight to each of these queues (and thereby to the corresponding traffic priorities). This weight sets the frequency at which each queue will be polled for service, and subsequently affects the response time for software applications assigned a specific priority value.

Note: This switch does not allow the queue service weights to be set. The weights are fixed as 1, 2, 4, 8, for queues 0 through 3 respectively.

Command Attributes

- **Interface** – Select port or trunk as an interface.
- **WRR Setting Table**¹⁴ – Displays a list of weights for each traffic class (i.e., queue).
- **Weight Value** – Set a new weight for the selected traffic class. (Range: 1-15)

Web – Click Priority, Queue Scheduling. Select the required interface, highlight a traffic class (i.e., output queue), enter a weight, then click Apply.

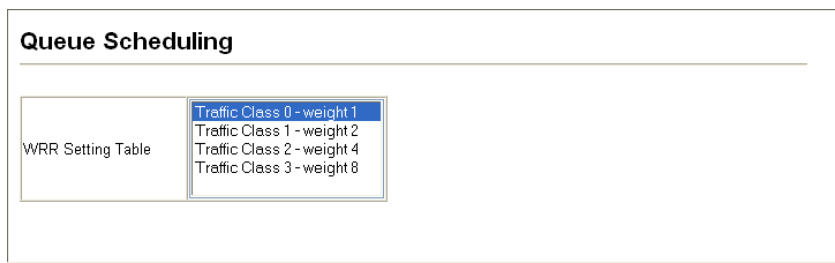

Figure 3-122 Configuring Queue Scheduling

CLI – The following example shows how to display the WRR weights assigned to each of the priority queues.

```
Console#show queue bandwidth 4-268
Queue ID  Weight
-----  -
0         1
1         2
2         4
3         8
Console
```

Layer 3/4 Priority Settings

Mapping Layer 3/4 Priorities to CoS Values

This switch supports one method of prioritizing layer 3/4 traffic to meet application requirements. Traffic priorities can be specified in the IP header of a frame using the number of the TCP port. When these service is enabled, the priorities are mapped to

14. CLI shows Queue ID.

a Class of Service value by the switch, and the traffic then sent to the corresponding output queue.

Because different priority information may be contained in the traffic, this switch maps priority values to the output queues in the following manner:

- The precedence for priority mapping is IP DSCP Priority, and then Default Port Priority.

Enabling IP DSCP Priority

The switch allows you to enable or disable the IP DSCP priority.

Command Attributes

- **IP DSCP Priority Status** – The following options are:
 - **Disabled** – Disables the priority service. (Default Setting: Disabled)
 - **IP DSCP** – Maps layer 3/4 priorities using Differentiated Services Code Point Mapping.

Web – Click Priority, IP DSCP Priority Status. Select IP DSCP from the drop down menu, then click Apply.

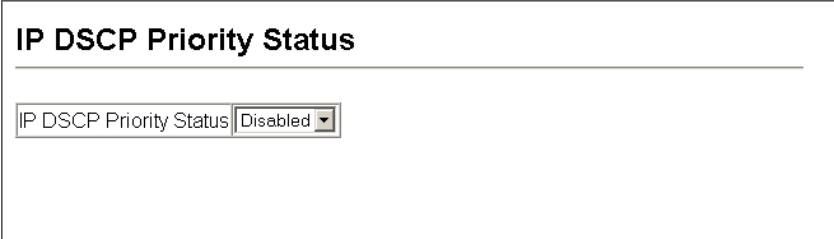

IP DSCP Priority Status

IP DSCP Priority Status Disabled ▾

Figure 3-123 IP DSCP Priority Status

Mapping DSCP Priority

The DSCP is six bits wide, allowing coding for up to 64 different forwarding behaviors. The DSCP retains backward compatibility with the three precedence bits so that non-DSCP compliant will not conflict with the DSCP mapping. Based on network policies, different kinds of traffic can be marked for different kinds of forwarding. The DSCP default values are defined in the following table. Note that all the DSCP values that are not specified are mapped to CoS value 0.

Table 3-14 Mapping DSCP Priority Values

IP DSCP Value	CoS Value
0	0
8	1
10, 12, 14, 16	2
18, 20, 22, 24	3
26, 28, 30, 32, 34, 36	4
38, 40, 42	5
48	6
46, 56	7

Command Attributes

- **DSCP Priority Table** – Shows the DSCP Priority to CoS map.
- **Class of Service Value** – Maps a CoS value to the selected DSCP Priority value. Note that “0” represents low priority and “7” represent high priority.

Note: IP DSCP settings apply to all interfaces.

Web – Click Priority, IP DSCP Priority. Select an entry from the DSCP table, enter a value in the Class of Service Value field, then click Apply.

IP DSCP Priority

DSCP Priority Table

DSCP 0 - CoS 0 ▲

DSCP 1 - CoS 0 ▲

DSCP 2 - CoS 0 ▲

DSCP 3 - CoS 0 ▲

DSCP 4 - CoS 0 ▲

DSCP 5 - CoS 0 ▲

DSCP 6 - CoS 0 ▼

Class of Service Value (0-7)

Figure 3-124 Mapping IP DSCP Priority Values

CLI – The following example globally enables DSCP Priority service on the switch, maps DSCP value 0 to CoS value 1 (on port 1), and then displays the DSCP Priority settings.

```

Console(config)#map ip dscp 4-269
Console(config)#interface ethernet 1/1 4-166
Console(config-if)#map ip dscp 1 cos 0 4-270
Console(config-if)#end
Console#show map ip dscp ethernet 1/1 4-271
DSCP mapping status: disabled

  Port      DSCP COS
  -----
  Eth 1/ 1   0   0
  Eth 1/ 1   1   0
  Eth 1/ 1   2   0
  Eth 1/ 1   3   0
  :
  Eth 1/ 1  61   0
  Eth 1/ 1  62   0
  Eth 1/ 1  63   0
Console#

```

* Mapping specific values for IP DSCP is implemented as an interface configuration command, but any changes will apply to the all interfaces on the switch.

Quality of Service

The commands described in this section are used to configure Quality of Service (QoS) classification criteria and service policies. Differentiated Services (DiffServ) provides policy-based management mechanisms used for prioritizing network resources to meet the requirements of specific traffic types on a per hop basis. Each packet is classified upon entry into the network based on access lists, IP Precedence, DSCP values, or VLAN lists. Using access lists allows you select traffic based on Layer 2, Layer 3, or Layer 4 information contained in each packet. Based on configured network policies, different kinds of traffic can be marked for different kinds of forwarding.

All switches or routers that access the Internet rely on class information to provide the same forwarding treatment to packets in the same class. Class information can be assigned by end hosts, or switches or routers along the path. Priority can then be assigned based on a general policy, or a detailed examination of the packet. However, note that detailed examination of packets should take place close to the network edge so that core switches and routers are not overloaded.

Switches and routers along the path can use class information to prioritize the resources allocated to different traffic classes. The manner in which an individual device handles traffic in the DiffServ architecture is called per-hop behavior. All devices along a path should be configured in a consistent manner to construct a consistent end-to-end QoS solution.

Notes: 1. You can configure up to 16 rules per Class Map. You can also include multiple classes in a Policy Map.

3 Configuring the Switch

2. You should create a Class Map before creating a Policy Map. Otherwise, you will not be able to select a Class Map from the Policy Rule Settings screen (see page 3-207).

Configuring Quality of Service Parameters

To create a service policy for a specific category or ingress traffic, follow these steps:

1. Use the “Class Map” to designate a class name for a specific category of traffic.
2. Edit the rules for each class to specify a type of traffic based on an access list, a DSCP or IP Precedence value, or a VLAN.
3. Use the “Policy Map” to designate a policy name for a specific manner in which ingress traffic will be handled.
4. Add one or more classes to the Policy Map. Assign policy rules to each class by “setting” the QoS value to be assigned to the matching traffic class. The policy rule can also be configured to monitor the average flow and burst rate, and drop any traffic that exceeds the specified rate, or just reduce the DSCP service level for traffic exceeding the specified rate.
5. Use the “Service Policy” to assign a policy map to a specific interface.

Configuring a Class Map

A class map is used for matching packets to a specified class.

Command Usage

- To configure a Class Map, follow these steps:
 - Open the Class Map page, and click Add Class.
 - When the Class Configuration page opens, fill in the “Class Name” field, and click Add.
 - When the Match Class Settings page opens, specify type of traffic for this class based on an access list, a DSCP or IP Precedence value, or a VLAN, and click the Add button next to the field for the selected traffic criteria. You can specify up to 16 items to match when assigning ingress traffic to a class map.
- The class map is used with a policy map (page 3-205) to create a service policy (page 3-208) for a specific interface that defines packet classification, service tagging, and bandwidth policing. Note that one or more class maps can be assigned to a policy map.

Command Attributes

Class Map

- **Modify Name and Description** – Configures the name and a brief description of a class map. (Range: 1-16 characters for the name; 1-64 characters for the description)
- **Edit Rules** – Opens the “Match Class Settings” page for the selected class entry. Modify the criteria used to classify ingress traffic on this page.

- **Add Class** – Opens the “Class Configuration” page. Enter a class name and description on this page, and click Add to open the “Match Class Settings” page. Enter the criteria used to classify ingress traffic on this page.
- **Remove Class** – Removes the selected class.

Class Configuration

- **Class Name** – Name of the class map. (Range: 1-16 characters)
- **Type** – Only one match command is permitted per class map, so the match-any field refers to the criteria specified by the lone match command.
- **Description** – A brief description of a class map. (Range: 1-64 characters)
- **Add** – Adds the specified class.
- **Back** – Returns to previous page with making any changes.

Match Class Settings

- **Class Name** – List of class maps.
- **ACL List** – Name of an access control list. Any type of ACL can be specified, including standard or extended IP ACLs and MAC ACLs. (Range: 1-16 characters)
- **IP DSCP** – A DSCP value. (Range: 0-63)
- **IP Precedence** – An IP Precedence value. (Range: 0-7)
- **VLAN** – A VLAN. (Range:1-4092)
- **Add** – Adds specified criteria to the class. Up to 16 items are permitted per class.
- **Remove** – Deletes the selected criteria from the class.

3 Configuring the Switch

Web – Click QoS, DiffServ, then click Add Class to create a new class, or Edit Rules to change the rules of an existing class.

The screenshot displays the configuration interface for Class Maps, divided into three main sections:

- Class Map:** Contains a table with columns for Class Name, Type, and Description. A checkbox is present next to the Class Name field. Above the table are buttons for 'Modify Name & Description', 'Edit Rules', 'Add Class', and 'Remove Class'. Arrows point from the 'Edit Rules' and 'Add Class' buttons to the 'Match Class Settings' section.
- Class Configuration:** Features input fields for 'Class Name', a dropdown for 'Type' (set to 'match-any'), and a large text area for 'Description'. 'Add' and 'Back' buttons are located at the bottom right.
- Match Class Settings:** Shows the 'Class Name' as 'classname2' and the 'match-any' rule. Below this are four rows of settings, each with an input field and an 'Add' button:
 - ACL List: (none)
 - IP DSCP (0-63):
 - IP Precedence (0-7):
 - VLAN (1-4092):

Figure 3-125 Configuring Class Maps

CLI - This example creates a class map call "rd_class," and sets it to match packets marked for DSCP service value 3.

```
Console(config)#class-map rd_class match-any 4-198
Console(config-cmap)#match ip dscp 3 4-199
Console(config-cmap)#
```

Creating QoS Policies

This function creates a policy map that can be attached to multiple interfaces.

Command Usage

- To configure a Policy Map, follow these steps:
 - Create a Class Map as described on page 3-202.
 - Open the Policy Map page, and click Add Policy.
 - When the Policy Configuration page opens, fill in the “Policy Name” field, and click Add.
 - When the Policy Rule Settings page opens, select a class name from the scroll-down list (Class Name field). Configure a policy for traffic that matches criteria defined in this class by setting the quality of service that an IP packet will receive (in the Action field), defining the maximum throughput and burst rate (in the Meter field), and the action that results from a policy violation (in the Exceed field). Then finally click Add to register the new policy.
- A policy map can contain multiple class statements that can be applied to the same interface with the Service Policy Settings (page 3-208). You can configure up to 64 policers (i.e., meters or class maps) for each of the following access list types: MAC ACL, IP ACL (including Standard ACL and Extended ACL), IPv6 Standard ACL, and IPv6 Extended ACL. This limitation applies to ports 1-28. Also, note that the maximum number of classes that can be applied to a policy map is 16.
Policing is based on a token bucket, where bucket depth (i.e., the maximum burst before the bucket overflows) is specified by the “Burst” field, and the average rate at which tokens are removed from the bucket is specified by the “Rate” option.
- After using the policy map to define packet classification, service tagging, and bandwidth policing, it must be assigned to a specific interface by a service policy (page 3-208) to take effect.

Command Attributes

Policy Map

- **Modify Name and Description** – Configures the name and a brief description of a policy map. (Range: 1-16 characters for the name; 1-64 characters for the description)
- **Edit Classes** – Opens the “Policy Rule Settings” page for the selected class entry. Modify the criteria used to service ingress traffic on this page.
- **Add Policy** – Opens the “Policy Configuration” page. Enter a policy name and description on this page, and click Add to open the “Policy Rule Settings” page. Enter the criteria used to service ingress traffic on this page.
- **Remove Policy** – Deletes a specified policy.

Policy Configuration

- **Policy Name** — Name of policy map. (Range: 1-16 characters)
- **Description** – A brief description of a policy map. (Range: 1-64 characters)
- **Add** – Adds the specified policy.

3 Configuring the Switch

- **Back** – Returns to previous page with making any changes.

Policy Rule Settings

- Class Settings -

- **Class Name** – Name of class map.
- **Action** – Shows the service provided to ingress traffic by setting a CoS, DSCP, or IP Precedence value in a matching packet (as specified in Match Class Settings on page 3-202).
- **Meter** – The maximum throughput and burst rate.
 - **Rate (kbps)** – Rate in kilobits per second.
 - **Burst (byte)** – Burst in bytes.
- **Exceed Action** – Specifies whether the traffic that exceeds the specified rate will be dropped or the DSCP service level will be reduced.
- **Remove Class** – Deletes a class.

- Policy Options -

- **Class Name** – Name of class map.
- **Action** – Configures the service provided to ingress traffic by setting a CoS, DSCP, or IP Precedence value in a matching packet (as specified in Match Class Settings on page 3-202). (Range - CoS: 0-7, DSCP: 0-63, IP Precedence: 0-7, IPv6 DSCP: 0-63)
- **Meter** – Check this to define the maximum throughput, burst rate, and the action that results from a policy violation.
 - **Rate (kbps)** – Rate in kilobits per second. (Range: 1-100000 kbps or maximum port speed, whichever is lower)
 - **Burst (byte)** – Burst in bytes. (Range: 64-1522)
- **Exceed** – Specifies whether the traffic that exceeds the specified rate or burst will be dropped or the DSCP service level will be reduced.
 - **Set** – Decreases DSCP priority for out of conformance traffic. (Range: 0-63).
 - **Drop** – Drops out of conformance traffic.
- **Add** – Adds the specified criteria to the policy map.

Web – Click QoS, DiffServ, Policy Map to display the list of existing policy maps. To add a new policy map click Add Policy. To configure the policy rule settings click Edit Classes.

Policy Map

Modify Name & Description
Edit Classes
Add Policy
Remove Policy

	Policy Name	Description
<input type="checkbox"/>	Policy	

Policy Configuration

Policy Name

Description

Policy Rule Settings

Policy Name : Policy 2

Class Name	Action	Meter		Exceed Action
		Rate (bps)	Burst (byte)	

Class Name	(none) ▾		
Action	Set ▾	CoS (0-7) ▾	<input style="width: 50px;" type="text"/>
<input type="checkbox"/> Meter	Rate (1-100000)	<input style="width: 50px;" type="text"/> kbps	
	Burst (64-1522)	<input style="width: 50px;" type="text"/> byte	
Exceed	Set ▾	IP DSCP (0-63) ▾	<input style="width: 50px;" type="text"/>

Figure 3-126 Configuring Policy Maps

3 Configuring the Switch

CLI – This example creates a policy map called “rd-policy,” sets the average bandwidth the 1 Mbps, the burst rate to 1522 bps, and the response to reduce the DSCP value for violating packets to 0.

```
Console(config)#policy-map rd_policy#3          4-200
Console(config-pmap)#class rd_class#3         4-200
Console(config-pmap-c)#set ip_dscp 4          4-201
Console(config-pmap-c)#police 100000 1522 exceed-action
  set ip dscp 0                                4-202
Console(config-pmap-c)#
```

Attaching a Policy Map to Ingress Queues

This function binds a policy map to the ingress queue of a particular interface.

Command Usage

- You must first define a class map, then define a policy map, and finally bind the service policy to the required interface.
- You can only bind one policy map to an interface.
- The current firmware does not allow you to bind a policy map to an egress queue.

Command Attributes

- **Ports** – Specifies a port.
- **Ingress** – Applies the rule to ingress traffic.
- **Enabled** – Check this to enable a policy map on the specified port.
- **Policy Map** – Select the appropriate policy map from the scroll-down box.

Web – Click QoS, DiffServ, Service Policy Settings. Check Enabled and choose a Policy Map for a port from the scroll-down box, then click Apply.

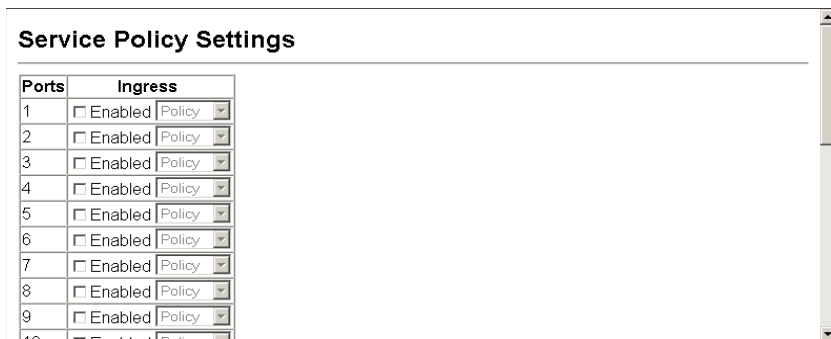

Figure 3-127 Service Policy Settings

CLI - This example applies a service policy to an ingress interface.

```
Console(config)#interface ethernet 1/5        4-120
Console(config-if)#service-policy input rd_policy#3  4-203
Console(config-if)#
```

VoIP Traffic Configuration

When IP telephony is deployed in an enterprise network, it is recommended to isolate the Voice over IP (VoIP) network traffic from other data traffic. Traffic isolation helps prevent excessive packet delays, packet loss, and jitter, which results in higher voice quality. This is best achieved by assigning all VoIP traffic to a single Voice VLAN.

The use of a Voice VLAN has several advantages. It provides security by isolating the VoIP traffic from other data traffic. End-to-end QoS policies and high priority can be applied to the VoIP VLAN traffic across the network, guaranteeing the bandwidth it needs. The VLAN isolation also protects against disruptive broadcast and multicast traffic that can seriously affect voice quality.

The switch allows you to specify the Voice VLAN for the network and set a CoS priority for the VoIP traffic. VoIP traffic can be detected on switch ports by using the source MAC address of packets, or by using LLDP (IEEE 802.1AB) to discover connected VoIP devices. When VoIP traffic is detected on a configured port, the switch automatically assigns the port as a tagged member the Voice VLAN. Alternatively, switch ports can be manually configured.

Configuring VoIP Traffic

To configure the switch for VoIP traffic, first enable the automatic detection of VoIP devices attached to switch ports, then set the Voice VLAN ID for the network. The Voice VLAN aging time can also be set to remove a port from the Voice VLAN when VoIP traffic is no longer received on the port.

Command Attributes

- **Auto Detection Status** – Enables the automatic detection of VoIP traffic on switch ports. (Default: Disabled)
- **Voice VLAN ID** – Sets the Voice VLAN ID for the network. Only one Voice VLAN is supported and it must already be created on the switch. (Range: 1-4094)
- **Voice VLAN Aging Time** – The time after which a port is removed from the Voice VLAN when VoIP traffic is no longer received on the port. (Range: 5-43200 minutes; Default: 1440 minutes).

Note: The Voice VLAN ID cannot be modified when the global Auto Detection Status is enabled.

3 Configuring the Switch

Web – Click QoS, VoIP Traffic Setting, Configuration. Enable Auto Detection, specify the Voice VLAN ID, then set the Voice VLAN Aging Time. Click Apply.

VoIP Traffic Configuration	
Auto Detection Status	<input checked="" type="checkbox"/> Enabled
Voice Vlan ID (1-4094)	<input type="text" value="1234"/>
Voice VLAN Aging Time (5-43200)	<input type="text" value="1440"/>

Figure 3-128 Configuring VoIP Traffic

CLI – This example enables VoIP traffic detection and specifies the Voice VLAN ID as 1234, then sets the VLAN aging time to 3000 seconds.

```
Console(config)#voice vlan 1234 4-281
Console(config)#voice vlan aging 3000 4-282
Console(config)#
```

Configuring VoIP Traffic Port

To configure ports for VoIP traffic, you need to set the mode (Auto or Manual), specify the discovery method to use, and set the traffic priority. You can also enable security filtering to ensure that only VoIP traffic is forwarded on the Voice VLAN.

Command Attributes

- **Mode** – Specifies if the port will be added to the Voice VLAN when VoIP traffic is detected. (Default: None)
 - **None** – The Voice VLAN feature is disabled on the port. The port will not detect VoIP traffic or be added to the Voice VLAN.
 - **Auto** – The port will be added as a tagged member to the Voice VLAN when VoIP traffic is detected on the port. You must select a method for detecting VoIP traffic, either OUI or 802.1ab (LLDP). When OUI is selected, be sure to configure the MAC address ranges in the Telephony OUI list.
 - **Manual** – The Voice VLAN feature is enabled on the port, but the port must be manually added to the Voice VLAN.
- **Security** – Enables security filtering that discards any non-VoIP packets received on the port that are tagged with voice VLAN ID. VoIP traffic is identified by source MAC addresses configured in the Telephony OUI list, or through LLDP that discovers VoIP devices attached to the switch. Packets received from non-VoIP sources are dropped. (Default: Disabled)
- **Discovery Protocol** – Selects a method to use for detecting VoIP traffic on the port. (Default: OUI)
 - **OUI** – Traffic from VoIP devices is detected by the Organizationally Unique Identifier (OUI) of the source MAC address. OUI numbers are assigned to manufacturers and form the first three octets of a device MAC address. MAC

address OUI numbers must be configured in the Telephony OUI list so that the switch recognizes the traffic as being from a VoIP device.

- **802.1ab** – Uses LLDP to discover VoIP devices attached to the port. LLDP checks that the “telephone bit” in the system capability TLV is turned on. See “Link Layer Discovery Protocol” on page 3-183 for more information on LLDP.
- **Priority** – Defines a CoS priority for the port traffic on the Voice VLAN. The priority of any received VoIP packet is overwritten with the new priority when the Voice VLAN feature is active for the port.

Web – Click QoS, VoIP Traffic Setting, Port Configuration. Set the mode for a VoIP traffic port, select the detection mechanism to use, and specify the VoIP traffic priority. Click Apply.

VoIP Traffic Port Configuration				
Port	Mode	Security	Discovery Protocol	Priority (0-6)
1	Auto	<input checked="" type="checkbox"/> Enabled	<input checked="" type="checkbox"/> OUI <input type="checkbox"/> 802.1ab	6
2	Manual	<input type="checkbox"/> Enabled	<input type="checkbox"/> OUI <input type="checkbox"/> 802.1ab	6
3	Auto	<input checked="" type="checkbox"/> Enabled	<input checked="" type="checkbox"/> OUI <input type="checkbox"/> 802.1ab	6
4	Auto	<input checked="" type="checkbox"/> Enabled	<input type="checkbox"/> OUI <input checked="" type="checkbox"/> 802.1ab	6
5	Auto	<input checked="" type="checkbox"/> Enabled	<input type="checkbox"/> OUI <input checked="" type="checkbox"/> 802.1ab	6
6	None	<input type="checkbox"/> Enabled	<input checked="" type="checkbox"/> OUI <input type="checkbox"/> 802.1ab	6
7	None	<input type="checkbox"/> Enabled	<input checked="" type="checkbox"/> OUI <input type="checkbox"/> 802.1ab	6
8	None	<input type="checkbox"/> Enabled	<input checked="" type="checkbox"/> OUI <input type="checkbox"/> 802.1ab	6
9	None	<input type="checkbox"/> Enabled	<input checked="" type="checkbox"/> OUI <input type="checkbox"/> 802.1ab	6
10	None	<input type="checkbox"/> Enabled	<input checked="" type="checkbox"/> OUI <input type="checkbox"/> 802.1ab	6
11	None	<input type="checkbox"/> Enabled	<input checked="" type="checkbox"/> OUI <input type="checkbox"/> 802.1ab	6
12	None	<input type="checkbox"/> Enabled	<input checked="" type="checkbox"/> OUI <input type="checkbox"/> 802.1ab	6

Figure 3-129 VoIP Traffic Port Configuration

3 Configuring the Switch

CLI – This example configures VoIP traffic settings for port 2 and displays the current Voice VLAN status.

```
Console(config)#interface ethernet 1/2
Console(config-if)#switchport voice vlan auto 4-283
Console(config-if)#switchport voice vlan security 4-284
Console(config-if)#switchport voice vlan rule oui 4-284
Console(config-if)#switchport voice vlan priority 5 4-285
Console(config-if)#exit
Console#show voice vlan status 4-286
Global Voice VLAN Status
Voice VLAN Status : Enabled
Voice VLAN ID : 1234
Voice VLAN aging time : 1440 minutes

Voice VLAN Port Summary
Port Mode Security Rule Priority
-----
Eth 1/ 1 Auto Enabled OUI 6
Eth 1/ 2 Auto Enabled OUI 5
Eth 1/ 3 Manual Enabled OUI 5
Eth 1/ 4 Auto Enabled OUI 6
Eth 1/ 5 Disabled Disabled OUI 6
Eth 1/ 6 Disabled Disabled OUI 6
Eth 1/ 7 Disabled Disabled OUI 6
Eth 1/ 8 Disabled Disabled OUI 6
Eth 1/ 9 Disabled Disabled OUI 6
Eth 1/10 Disabled Disabled OUI 6
Eth 1/11 Disabled Disabled OUI 6
Eth 1/12 Disabled Disabled OUI 6
Eth 1/13 Disabled Disabled OUI 6
Eth 1/14 Disabled Disabled OUI 6
Eth 1/15 Disabled Disabled OUI 6
Eth 1/16 Disabled Disabled OUI 6
Eth 1/17 Disabled Disabled OUI 6
Eth 1/18 Disabled Disabled OUI 6
Eth 1/19 Disabled Disabled OUI 6
Eth 1/20 Disabled Disabled OUI 6
Eth 1/21 Disabled Disabled OUI 6
Eth 1/22 Disabled Disabled OUI 6
Eth 1/23 Disabled Disabled OUI 6
Eth 1/24 Disabled Disabled OUI 6
Eth 1/25 Disabled Disabled OUI 6
Eth 1/26 Disabled Disabled OUI 6
Eth 1/27 Disabled Disabled OUI 6
Eth 1/28 Disabled Disabled OUI 6

Console#
```

Configuring Telephony OUI

VoIP devices attached to the switch can be identified by the manufacturer's Organizational Unique Identifier (OUI) in the source MAC address of received packets. OUI numbers are assigned to manufacturers and form the first three octets of device MAC addresses. The MAC OUI numbers for VoIP equipment can be configured on the switch so that traffic from these devices is recognized as VoIP.

Command Attributes

- **Telephony OUI** – Specifies a MAC address range to add to the list. Enter the MAC address in format 01-23-45-67-89-AB.
- **Mask** – Identifies a range of MAC addresses. Selecting a mask of FF-FF-FF-00-00-00 identifies all devices with the same OUI (the first three octets). Other masks restrict the MAC address range. Selecting FF-FF-FF-FF-FF-FF specifies a single MAC address. (Default: FF-FF-FF-00-00-00)
- **Description** – User-defined text that identifies the VoIP devices.

Web – Click QoS, VoIP Traffic Setting, OUI Configuration. Enter a MAC address that specifies the OUI for VoIP devices in the network. Select a mask from the pull-down list to define a MAC address range. Enter a description for the devices, then click Add.

Telephony OUI List

Current:

00-23-34-45-56-67_FF-FF-FF-00-00-00 , test
 00-11-22-33-AB-CD_FF-FF-FF-FF-FF-FF , Chris

New:

Telephony OUI	<input type="text"/>
Mask	FF-FF-FF-00-00-00 ▾
Description	<input type="text"/>

Figure 3-130 Telephony OUI List

CLI – This example adds an identifier to the list, then displays the current list

```

Console(config)#voice vlan mac-address 00-e0-bb-00-00-00 mask
ff-ff-ff-00-00-00 description old phones                               4-282
Console(config)#exit
Console#show voice vlan oui                                           4-286
OUIAddress      Mask                Description
00-e0-bb-00-00-00 FF-FF-FF-00-00-00 old phones
00-11-22-33-44-55 FF-FF-FF-00-00-00 new phones
00-98-76-54-32-10 FF-FF-FF-FF-FF-FF Chris' phone
Console#
  
```

Multicast Filtering

Multicasting is used to support real-time applications such as videoconferencing or streaming audio. A multicast server does not have to establish a separate connection with each client. It merely broadcasts its service to the network, and any hosts that want to receive the multicast register with their local multicast switch/router. Although this approach reduces the network overhead required by a multicast server, the broadcast traffic must be carefully pruned at every multicast switch/router it passes through to ensure that traffic is only passed on to the hosts which subscribed to this service.

This switch uses IGMP (Internet Group Management Protocol) to query for any attached hosts that want to receive a specific multicast service. It identifies the ports containing hosts requesting to join the service and sends data out to those ports only. It then propagates the service request up to any neighboring multicast switch/router to ensure that it will continue to receive the multicast service. This procedure is called multicast filtering.

The purpose of IP multicast filtering is to optimize a switched network's performance, so multicast packets will only be forwarded to those ports containing multicast group hosts or multicast routers/switches, instead of flooding traffic to all ports in the subnet (VLAN).

Layer 2 IGMP (Snooping and Query)

IGMP Snooping and Query – If multicast routing is not supported on other switches in your network, you can use IGMP Snooping and Query (page 3-215) to monitor IGMP service requests passing between multicast clients and servers, and dynamically configure the switch ports which need to forward multicast traffic.

When using IGMPv3 snooping, service requests from IGMP Version 1, 2 or 3 hosts are all forwarded to the upstream router as IGMPv3 reports. The primary enhancement provided by IGMPv3 snooping is in keeping track of information about the specific multicast sources which downstream IGMPv3 hosts have requested or refused. The switch maintains information about both multicast groups and channels, where a group indicates a multicast flow for which the hosts have not requested a specific source (the only option for IGMPv1 and v2 hosts unless statically configured on the switch), and a channel indicates a flow for which the hosts have requested service from a specific source.

Only IGMPv3 hosts can request service from a specific multicast source. When downstream hosts request service from a specific source for a multicast service,

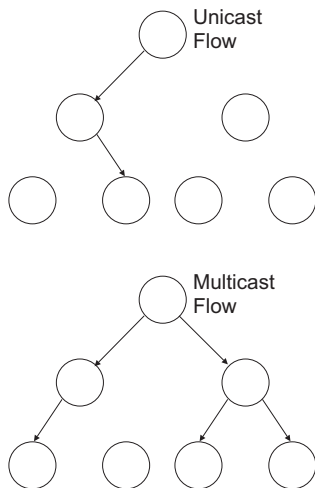

these sources are all placed in the Include list, and traffic is forwarded to the hosts from each of these sources. IGMPv3 hosts may also request that service be forwarded from all sources except for those specified. In this case, traffic is filtered from sources in the Exclude list, and forwarded from all other available sources.

- Notes:**
1. When the switch is configured to use IGMPv3 snooping, the snooping version may be downgraded to version 2 or version 1, depending on the version of the IGMP query packets detected on each VLAN.
 2. IGMP snooping will not function unless a multicast router port is enabled on the switch. This can be accomplished in one of two ways. A static router port can be manually configured (see “Specifying Static Interfaces for a Multicast Router” on page 3-219). Using this method, the router port is never timed out, and will continue to function until explicitly removed. The other method relies on the switch to dynamically create multicast routing ports whenever multicast routing protocol packets or IGMP query packets are detected on a port.
 3. A maximum of up to 255 multicast entries can be maintained for IGMP snooping, and 255 entries for Multicast Routing, when both of these features are enabled. If the table’s capacity is exceeded, the IGMPv3 snooping will not support multicast source filtering, but will forward multicast traffic from all relevant sources to the requesting hosts.

Static IGMP Router Interface – If IGMP snooping cannot locate the IGMP querier, you can manually designate a known IGMP querier (i.e., a multicast router/switch) connected over the network to an interface on your switch (page 3-219). This interface will then join all the current multicast groups supported by the attached router/switch to ensure that multicast traffic is passed to all appropriate interfaces within the switch.

Static IGMP Host Interface – For multicast applications that you need to control more carefully, you can manually assign a multicast service to specific interfaces on the switch (page 3-221).

Configuring IGMP Snooping and Query Parameters

You can configure the switch to forward multicast traffic intelligently. Based on the IGMP query and report messages, the switch forwards traffic only to the ports that request multicast traffic. This prevents the switch from broadcasting the traffic to all ports and possibly disrupting network performance.

Command Usage

- **IGMP Snooping** – This switch can passively snoop on IGMP Query and Report packets transferred between IP multicast routers/switches and IP multicast host groups to identify the IP multicast group members. It simply monitors the IGMP packets passing through it, picks out the group registration information, and configures the multicast filters accordingly.

Note: Unknown multicast traffic is flooded to all ports in the VLAN for several seconds when first received. If a multicast router port exists on the VLAN, the traffic will be filtered by subjecting it to IGMP snooping. If no router port exists on the VLAN or

3 Configuring the Switch

the multicast filtering table is already full, the switch will continue flooding the traffic into the VLAN.

- **IGMP Querier** — A router, or multicast-enabled switch, can periodically ask their hosts if they want to receive multicast traffic. If there is more than one router/switch on the LAN performing IP multicasting, one of these devices is elected “querier” and assumes the role of querying the LAN for group members. It then propagates the service requests on to any upstream multicast switch/router to ensure that it will continue to receive the multicast service.

Note: Multicast routers use this information, along with a multicast routing protocol such as DVMRP or PIM, to support IP multicasting across the Internet.

Command Attributes

- **IGMP Status** — When enabled, the switch will monitor network traffic to determine which hosts want to receive multicast traffic. This is also referred to as IGMP Snooping. (Default: Enabled)
- **Act as IGMP Querier** — When enabled, the switch can serve as the Querier, which is responsible for asking hosts if they want to receive multicast traffic. This feature is not supported for IGMPv3 snooping. (Default: Disabled)
- **IGMP Query Count** — Sets the maximum number of queries issued for which there has been no response before the switch takes action to drop a client from the multicast group. (Range: 2-10; Default: 2)
- **IGMP Query Interval** — Sets the frequency at which the switch sends IGMP host-query messages. (Range: 60-125 seconds; Default: 125)
- **IGMP Report Delay** — Sets the time between receiving an IGMP Report for an IP multicast address on a port before the switch sends an IGMP Query out of that port and removes the entry from its list. (Range: 5-25 seconds; Default: 10)
- **IGMP Query Timeout** — The time the switch waits after the previous querier stops before it considers the router port (i.e., the interface which had been receiving query packets) to have expired. (Range: 300-500 seconds; Default: 300)
- **IGMP Version** — Sets the protocol version for compatibility with other devices on the network. (Range: 1-3; Default: 2)

Notes:

1. All systems on the subnet must support the same version.
2. Some attributes are only enabled for IGMPv2 and/or v3, including Act as IGMP Querier, IGMP Report Delay and IGMP Query Timeout.

Web – Click IGMP Snooping, IGMP Configuration. Adjust the IGMP settings as required, and then click Apply. (The default settings are shown below.)

IGMP Configuration	
IGMP Status	<input checked="" type="checkbox"/> Enabled
Act as IGMP Querier	<input type="checkbox"/> Enabled
IGMP Query Count (2-10)	<input type="text" value="2"/>
IGMP Query Interval (60-125)	<input type="text" value="125"/> seconds
IGMP Report Delay (5-25)	<input type="text" value="10"/> seconds
IGMP Query Timeout (300-500)	<input type="text" value="300"/> seconds
IGMP Version (1,2,3)	<input type="text" value="2"/>

Figure 3-131 IGMP Configuration

CLI – This example modifies the settings for multicast filtering, and then displays the current status.

```

Console(config)#ip igmp snooping                                4-288
Console(config)#ip igmp snooping querier                      4-292
Console(config)#ip igmp snooping query-count 10              4-293
Console(config)#ip igmp snooping query-interval 100          4-293
Console(config)#ip igmp snooping query-max-response-time 20  4-294
Console(config)#ip igmp snooping router-port-expire-time 300 4-295
Console(config)#ip igmp snooping version 2                    4-289
Console(config)#exit
Console#show ip igmp snooping                                  4-289
Service status:      Enabled
Querier status:      Enabled
Leave proxy status:   Disabled
Query count:         10
Query interval:      100 sec
Query max response time: 20 sec
Router port expire time: 300 sec
Immediate Leave Processing: Disabled on all VLAN
IGMP snooping version: Version 2
Console#

```

Enabling IGMP Immediate Leave

The switch can be configured to immediately delete a member port of a multicast service if a leave packet is received at that port and the immediate-leave function is enabled for the parent VLAN.

Command Usage

- If immediate leave is *not* used, a multicast router (or querier) will send a group-specific query message when an IGMPv2/v3 group leave message is received. The router/querier stops forwarding traffic for that group only if no host replies to the query within the specified timeout period. Note that the timeout period

3 Configuring the Switch

is determined by the IGMP Query Report Delay (see “Configuring IGMP Snooping and Query Parameters” on page 3-215).

- If immediate leave is enabled, the switch assumes that only one host is connected to the interface. Therefore, immediate leave should only be enabled on an interface if it is connected to only one IGMP-enabled device, either a service host or a neighbor running IGMP snooping.
- Immediate leave is only effective if IGMP snooping is enabled, and IGMPv2 or IGMPv3 snooping is used.

Command Attributes

- **VLAN ID** – VLAN Identifier. (Range: 1-4093).
- **Immediate Leave** – Sets the status for immediate leave on the specified VLAN. (Default: Disabled)

Web – Click IGMP Snooping, IGMP Immediate Leave. Select the VLAN interface to configure, set the status for immediate leave, and click Apply.

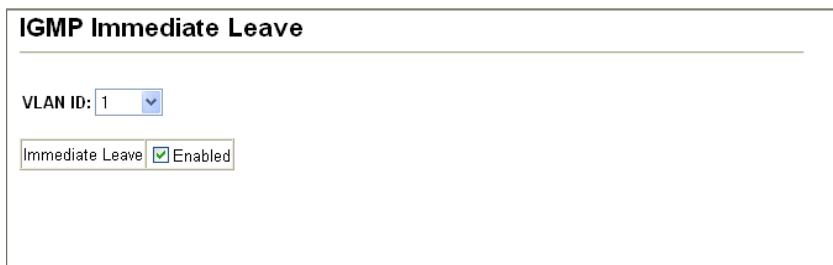

IGMP Immediate Leave

VLAN ID: 1

Immediate Leave Enabled

Figure 3-132 IGMP Immediate Leave

CLI – This example enables IGMP immediate leave for VLAN 1 and then displays the current IGMP snooping status.

```
Console(config)#interface vlan 1
Console(config-if)#ip igmp snooping immediate-leave 4-290
Console(config-if)#end
Console#show ip igmp snooping 4-289
Service Status: Enabled
Querier Status: Disabled
Leave proxy status: Enabled
Query Count: 2
Query Interval: 125 sec
Query Max Response Time: 10 sec
Router Port Expire Time: 300 sec
Immediate Leave Processing: Enabled on VLAN 1,
IGMP Snooping Version: Version 2
Console#
```

Displaying Interfaces Attached to a Multicast Router

Multicast routers that are attached to ports on the switch use information obtained from IGMP, along with a multicast routing protocol such as DVMRP or PIM, to

support IP multicasting across the Internet. These routers may be dynamically discovered by the switch or statically assigned to an interface on the switch.

You can use the Multicast Router Port Information page to display the ports on this switch attached to a neighboring multicast router/switch for each VLAN ID.

Command Attributes

- **VLAN ID** – ID of configured VLAN (1-4093).
- **Multicast Router List** – Multicast routers dynamically discovered by this switch or those that are statically assigned to an interface on this switch.

Web – Click IGMP Snooping, Multicast Router Port Information. Select the required VLAN ID from the scroll-down list to display the associated multicast routers.

Figure 3-133 Displaying Multicast Router Port Information

CLI – This example shows that Port 11 has been statically configured as a port attached to a multicast router.

```
Console#show ip igmp snooping mrouter vlan 14-296
VLAN M'cast Router Port Type
-----
1           Eth 1/11 Static
Console#
```

Specifying Static Interfaces for a Multicast Router

Depending on your network connections, IGMP snooping may not always be able to locate the IGMP querier. Therefore, if the IGMP querier is a known multicast router/switch connected over the network to an interface (port or trunk) on your switch, you can manually configure the interface (and a specified VLAN) to join all the current multicast groups supported by the attached router. This can ensure that multicast traffic is passed to all the appropriate interfaces within the switch.

Command Attributes

- **Interface** – Activates the Port or Trunk scroll down list.
- **VLAN ID** – Selects the VLAN to propagate all multicast traffic coming from the attached multicast router.

3 Configuring the Switch

- **Port** or **Trunk** – Specifies the interface attached to a multicast router.

Web – Click IGMP Snooping, Static Multicast Router Port Configuration. Specify the interfaces attached to a multicast router, indicate the VLAN which will forward all the corresponding multicast traffic, and then click Add. After you have finished adding interfaces to the list, click Apply.

Static Multicast Router Port Configuration

Current:

Vlan1, Unit1 Port1

<<Add

Remove

New:

Interface	Port
VLAN ID	1
Port	1
Trunk	

Figure 3-134 Static Multicast Router Port Configuration

CLI – This example configures port 1 as a multicast router port within VLAN 1.

```
Console(config)#ip igmp snooping vlan 1 mrouter ethernet 1/14-296
Console(config)#exit
Console#show ip igmp snooping mrouter vlan 14-296
  VLAN M'cast Router Port Type
  ----
    1           Eth 1/1  Static
Console#
```

Displaying Port Members of Multicast Services

You can display the port members associated with a specified VLAN and multicast service.

Command Attributes

- **VLAN ID** – Selects the VLAN for which to display port members. (Range: 1-4093)
- **Multicast IP Address** – The IP address for a specific multicast service.
- **Multicast Group Port List** – Shows the interfaces that have already been assigned to the selected VLAN to propagate a specific multicast service.

Web – Click IGMP Snooping, IP Multicast Registration Table. Select a VLAN ID and the IP address for a multicast service from the scroll-down lists. The switch will display all the interfaces that are propagating this multicast service.

IP Multicast Registration Table

VLAN ID:

Multicast IP Address:

Multicast Group Port List:

Unit1 Port1, User

Figure 3-135 IP Multicast Registration Table

CLI – This example displays all the known multicast services supported on VLAN 1, along with the ports propagating the corresponding services. The Type field shows if this entry was learned dynamically or was statically configured.

```

Console#show bridge 1 multicast vlan 14-291
VLAN M'cast IP addr. Member ports Type
-----
  1      224.1.1.12    Eth1/12    USER
  1      224.1.1.2.3    Eth1/12    IGMP
Console#
  
```

Assigning Ports to Multicast Services

Multicast filtering can be dynamically configured using IGMP Snooping and IGMP Query messages as described in “Configuring IGMP snooping and Query Parameters” on page 3-133. For certain applications that require tighter control, you may need to statically configure a multicast service on the switch. First add all the ports attached to participating hosts to a common VLAN, and then assign the multicast service to that VLAN group.

Command Usage

- Static multicast addresses are never aged out.
- When a multicast address is assigned to an interface in a specific VLAN, the corresponding traffic can only be forwarded to ports within that VLAN.

Command Attributes

- **Interface** – Activates the Port or Trunk scroll down list.
- **VLAN ID** – Selects the VLAN to propagate all multicast traffic coming from the attached multicast router/switch. (Range: 1-4093)

3 Configuring the Switch

- **Multicast IP** – The IP address for a specific multicast service
- **Port or Trunk** – Specifies the interface attached to a multicast router/switch.

Web – Click IGMP Snooping, IGMP Member Port Table. Specify the interface attached to a multicast service (via an IGMP-enabled switch or multicast router), indicate the VLAN that will propagate the multicast service, specify the multicast IP address, and click Add. After you have completed adding ports to the member list, click Apply.

Figure 3-136 IGMP Member Port Table

CLI – This example assigns a multicast address to VLAN 1, and then displays all the known multicast services supported on VLAN 1.

```
Console(config)#ip igmp snooping vlan 1 static 224.1.1.12          4-288
  ethernet 1/12
Console(config)#exit
Console#show mac-address-table multicast vlan 1                    4-291
VLAN M'cast IP addr. Member ports Type
-----
  1      224.1.1.12      Eth1/12  USER
  1      224.1.2.3       Eth1/12  IGMP
Console#
```

IGMP Filtering and Throttling

In certain switch applications, the administrator may want to control the multicast services that are available to end users. For example, an IP/TV service based on a specific subscription plan. The IGMP filtering feature fulfills this requirement by restricting access to specified multicast services on a switch port, and IGMP throttling limits the number of simultaneous multicast groups a port can join.

IGMP filtering enables you to assign a profile to a switch port that specifies multicast groups that are permitted or denied on the port. An IGMP filter profile can contain one or more, or a range of multicast addresses; but only one profile can be assigned to a port. When enabled, IGMP join reports received on the port are checked against the filter profile. If a requested multicast group is permitted, the IGMP join report is forwarded as normal. If a requested multicast group is denied, the IGMP join report is dropped.

IGMP throttling sets a maximum number of multicast groups that a port can join at the same time. When the maximum number of groups is reached on a port, the switch can take one of two actions; either “deny” or “replace”. If the action is set to deny, any new IGMP join reports will be dropped. If the action is set to replace, the switch randomly removes an existing group and replaces it with the new multicast group.

Note: IGMP filtering and throttling only applies to dynamically learned multicast groups. It does not apply to statically configured groups.

Enabling IGMP Filtering and Throttling

To implement IGMP filtering and throttling on the switch, you must first enable the feature globally and create IGMP profile numbers.

Command Attributes

- **IGMP Filter** – Enables IGMP filtering and throttling globally for the switch. (Default: Disabled)
- **IGMP Profile** – Creates IGMP profile numbers. (Range: 1-4294967295)

Web – Click IGMP Snooping, IGMP Filter Configuration. Create a profile group by entering a number in the text box and clicking Add. Enable the IGMP filter status, then click Apply.

IGMP Filter Status

IGMP Filter
 Enabled

IGMP Profile Configuration

Current:

25

New:

IGMP Profile
(1-4294967295)

Figure 3-137 Enabling IGMP Filtering and Throttling

3 Configuring the Switch

CLI – This example enables IGMP filtering and creates a profile number. It then displays the current status and the existing profile numbers.

```
Console(config)#ip igmp filter 4-298
Console(config)#ip igmp profile 19 4-298
Console(config)#end
Console#show ip igmp profile 4-302
IGMP Profile 19
IGMP Profile 25
Console#
```

Configuring IGMP Filter Profiles

When you have created an IGMP profile number, you can then configure the multicast groups to filter and set the access mode.

Command Usage

- Each profile has only one access mode; either permit or deny.
- When the access mode is set to permit, IGMP join reports are processed when a multicast group falls within the controlled range. When the access mode is set to deny, IGMP join reports are only processed when the multicast group is not in the controlled range.

Command Attributes

- **Profile ID** – Selects an existing profile number to configure. After selecting an ID number, click the Query button to display the current configuration.
- **Access Mode** – Sets the access mode of the profile; either permit or deny. (Default: Deny)
- **New Multicast Address Range List** – Specifies multicast groups to include in the profile. Specify a multicast group range by entering the same IP address for the start and end of the range. Click the Add button to add a range to the current list.
- **Current Multicast Address Range List** – Lists multicast groups currently included in the profile. Select an entry and click the Remove button to delete it from the list.

Web – Click IGMP Snooping, IGMP Filter Profile Configuration. Select the profile number you want to configure; then click Query to display the current settings. Specify the access mode for the profile and then add multicast groups to the profile list. Click Apply.

IGMP Profile Group Configuration

Profile ID:

i@

Access Mode

Current Multicast Address Range List

239.1.2.3 239.1.2.3

239.2.3.1 239.2.3.200

New Multicast Address Range List:

Start Multicast Address	<input type="text"/>
End Multicast Address	<input type="text"/>

Figure 3-138 IGMP Profile Configuration

CLI – This example configures profile number 19 by setting the access mode to “permit” and then specifying a range of multicast groups that a user can join. The current profile configuration is then displayed.

```

Console(config)#ip igmp profile 19                                4-298
Console(config-igmp-profile)#permit                             4-299
Console(config-igmp-profile)#range 239.1.2.3                  4-299
Console(config-igmp-profile)#range 239.2.3.1 239.2.3.200
Console(config-igmp-profile)#end
Console#show ip igmp profile 19                                4-302
IGMP Profile 19
  permit
  range 239.1.2.3 239.1.2.3
  range 239.2.3.1 239.2.3.200
Console#

```

Configuring IGMP Filtering and Throttling for Interfaces

Once you have configured IGMP profiles, you can assign them to interfaces on the switch. Also you can set the IGMP throttling number to limit the number of multicast groups an interface can join at the same time.

Command Usage

- Only one profile can be assigned to an interface.

3 Configuring the Switch

- An IGMP profile or throttling setting can also be applied to a trunk interface. When ports are configured as trunk members, the trunk uses the settings applied to the first port member in the trunk.
- IGMP throttling sets a maximum number of multicast groups that a port can join at the same time. When the maximum number of groups is reached on a port, the switch can take one of two actions; either “deny” or “replace”. If the action is set to deny, any new IGMP join reports will be dropped. If the action is set to replace, the switch randomly removes an existing group and replaces it with the new multicast group.

Command Attributes

- **Profile** – Selects an existing profile number to assign to an interface.
- **Max Multicast Groups** – Sets the maximum number of multicast groups an interface can join at the same time. (Range: 0-255; Default: 255)
- **Current Multicast Groups** – Displays the current multicast groups the interface has joined.
- **Throttling Action Mode** – Sets the action to take when the maximum number of multicast groups for the interface has been exceeded. (Default: Deny)
 - **deny** - The new multicast group join report is dropped.
 - **replace** - The new multicast group replaces an existing group.
- **Throttling Status** – Indicates if the throttling action has been implemented on the interface. (Options: True or False)
- **Trunk** – Indicates if a port is a trunk member.

Web – Click IGMP Snooping, IGMP Filter/Throttling Port Configuration or IGMP Filter/Throttling Trunk Configuration. Select a profile to assign to an interface, then set the throttling number and action. Click Apply.

IGMP Filter and Throttling Port Configuration						
Port	Profile	Max Multicast Groups (0-256)	Current Multicast Groups	Throttling Action Mode	Throttling Status	Trunk
1	19	64	0	deny	True	
2	19	256	0	deny	False	
3	19	256	0	deny	False	
4	19	256	0	deny	False	
5	19	256	0	deny	False	
6	19	256	0	deny	False	
7	19	256	0	deny	False	
8	19	256	0	deny	False	
9	19	256	0	deny	False	
10	19	256	0	deny	False	
11	19	256	0	deny	False	
12	19	256	0	deny	False	

Figure 3-139 IGMP Filter and Throttling Port Configuration

CLI – This example assigns IGMP profile number 19 to port 1, and then sets the throttling number and action. The current IGMP filtering and throttling settings for the interface are then displayed.

```
Console(config)#interface ethernet 1/1 4-166
Console(config-if)#ip igmp filter 19 4-300
Console(config-if)#ip igmp max-groups 64 4-300
Console(config-if)#ip igmp max-groups action deny 4-301
Console(config-if)#end
Console#show ip igmp filter interface ethernet 1/1 4-302
Information of Eth 1/1
IGMP Profile 19
  permit
  range 239.1.2.3 239.1.2.3
  range 239.2.3.1 239.2.3.200
Console#show ip igmp throttle interface ethernet 1/1 4-303
Information of Eth 1/1
  status : TRUE
  action : deny
  max multicast groups : 64
  current multicast groups: 0
Console#
```

Multicast VLAN Registration

Multicast VLAN Registration (MVR) is a protocol that controls access to a single network-wide VLAN most commonly used for transmitting multicast traffic (such as television channels or video-on-demand) across a service provider's network. Any multicast traffic entering an MVR VLAN is sent to all attached subscribers. This protocol can significantly reduce the processing overhead required to dynamically monitor and establish the distribution tree for a normal multicast VLAN. This makes it possible to support common multicast services over a wide part of the network without having to use any multicast routing protocol.

MVR maintains the user isolation and data security provided by VLAN segregation by passing only multicast traffic into other VLANs to which the subscribers belong. Even though common multicast streams are passed onto different VLAN groups from the MVR VLAN, users in different IEEE 802.1Q or private VLANs cannot exchange any information (except through upper-level routing services).

3 Configuring the Switch

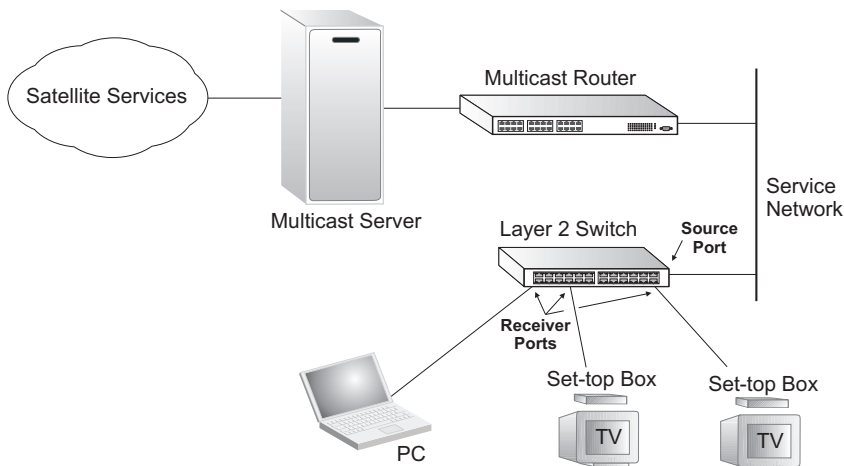

General Configuration Guidelines for MVR

1. Enable MVR globally on the switch, select the MVR VLAN, and add the multicast groups that will stream traffic to attached hosts (see “Configuring Global MVR Settings” on page 3-228).
2. Set the interfaces that will join the MVR as source ports or receiver ports (see “Configuring MVR Interface Status” on page 3-231).
3. Enable IGMP Snooping to allow a subscriber to dynamically join or leave an MVR group (see “Configuring IGMP Snooping and Query Parameters” on page 3-215). Note that only IGMP version 2 or 3 hosts can issue multicast join or leave messages.
4. For multicast streams that will run for a long term and be associated with a stable set of hosts, you can statically bind the multicast group to the participating interfaces (see “Assigning Static Multicast Groups to Interfaces” on page 3-233).

Configuring Global MVR Settings

The global settings for Multicast VLAN Registration (MVR) include enabling or disabling MVR for the switch, selecting the VLAN that will serve as the sole channel for common multicast streams supported by the service provider, and assigning the multicast group address for each of these services to the MVR VLAN.

Command Attributes

- **MVR Status** – When MVR is enabled on the switch, any multicast data associated with an MVR group is sent from all designated source ports, and to all receiver ports that have registered to receive data from that multicast group. (Default: Disabled)

- **MVR Running Status** – Indicates whether or not all necessary conditions in the MVR environment are satisfied.
- **MVR VLAN** – Identifier of the VLAN that serves as the channel for streaming multicast services using MVR. (Range: 1-4093; Default: 1)
- **MVR Group IP** – IP address for an MVR multicast group. The IP address range of 224.0.0.0 to 239.255.255.255 is used for multicast streams. MVR group addresses cannot fall within the reserved IP multicast address range of 224.0.0.x. (Range: 224.0.1.0 - 239.255.255.255; Default: no groups are assigned to the MVR VLAN)
- **Count** – The number of contiguous MVR group addresses. (Range: 1-255; Default: 0)

Web – Click MVR, Configuration. Enable MVR globally on the switch, select the MVR VLAN, add the multicast groups that will stream traffic to attached hosts, and then click Apply.

MVR Configuration

MVR Status	<input type="checkbox"/> Enabled
MVR Running Status	False
MVR VLAN	1

MVR Group IP List:

Current: **New:**

(none)	<input type="button" value=" << Add"/>	MVR Group IP	
	<input type="button" value=" Remove"/>	Count	

Figure 3-140 MVR Global Configuration

CLI – This example first enables IGMP snooping, enables MVR globally, and then configures a range of MVR group addresses.

```

Console(config)#ip igmp snooping           4-288
Console(config)#mvr                        4-304
Console(config)#mvr group 228.1.23.1 10    4-304
Console(config)#

```

Displaying MVR Interface Status

You can display information about the interfaces attached to the MVR VLAN.

Field Attributes

- **Type** – Shows the MVR port type.
- **Oper Status** – Shows the link status.

3 Configuring the Switch

- **MVR Status** – Shows the MVR status. MVR status for source ports is “ACTIVE” if MVR is globally enabled on the switch. MVR status for receiver ports is “ACTIVE” only if there are subscribers receiving multicast traffic from one of the MVR groups, or a multicast group has been statically assigned to an interface.
- **Immediate Leave** – Shows if immediate leave is enabled or disabled.
- **Trunk Member**¹⁵ – Shows if port is a trunk member.

Web – Click MVR, Port or Trunk Information.

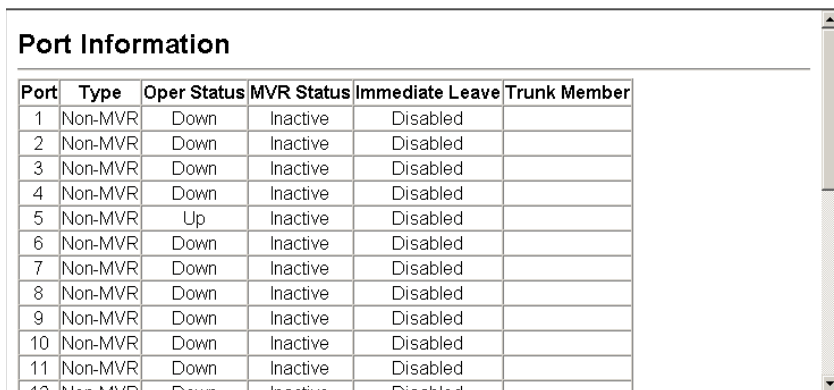

Port	Type	Oper Status	MVR Status	Immediate Leave	Trunk Member
1	Non-MVR	Down	Inactive	Disabled	
2	Non-MVR	Down	Inactive	Disabled	
3	Non-MVR	Down	Inactive	Disabled	
4	Non-MVR	Down	Inactive	Disabled	
5	Non-MVR	Up	Inactive	Disabled	
6	Non-MVR	Down	Inactive	Disabled	
7	Non-MVR	Down	Inactive	Disabled	
8	Non-MVR	Down	Inactive	Disabled	
9	Non-MVR	Down	Inactive	Disabled	
10	Non-MVR	Down	Inactive	Disabled	
11	Non-MVR	Down	Inactive	Disabled	
12	Non-MVR	Down	Inactive	Disabled	

Figure 3-141 MVR Port Information

CLI – This example shows information about interfaces attached to the MVR VLAN.

```
Console#show mvr interface 4-307
Port      Type      Status      Immediate Leave
-----
eth1/1    SOURCE    ACTIVE/UP    Disable
eth1/2    RECEIVER ACTIVE/UP    Disable
Console#
```

Displaying Port Members of Multicast Groups

You can display the multicast groups assigned to the MVR VLAN either through IGMP snooping or static configuration.

Field Attributes

- **Group IP** – Multicast groups assigned to the MVR VLAN.
- **Group Port List** – Shows the interfaces with subscribers for multicast services provided through the MVR VLAN.

15. Port Information only.

Web – Click MVR, Group IP Information.

MVR Group IP Table

Group IP: (none)

Group Port List:

(none)

Figure 3-142 MVR Group IP Information

CLI – This example following shows information about the interfaces associated with multicast groups assigned to the MVR VLAN.

```

Console#show mvr interface 4-307
MVR Group IP      Status      Members
-----
225.0.0.1         ACTIVE     eth1/1(d), eth1/2(s)
225.0.0.2         INACTIVE   None
225.0.0.3         INACTIVE   None
225.0.0.4         INACTIVE   None
225.0.0.5         INACTIVE   None
225.0.0.6         INACTIVE   None
225.0.0.7         INACTIVE   None
225.0.0.8         INACTIVE   None
225.0.0.9         INACTIVE   None
225.0.0.10        INACTIVE   None
Console#

```

Configuring MVR Interface Status

Each interface that participates in the MVR VLAN must be configured as an MVR source port or receiver port. If only one subscriber attached to an interface is receiving multicast services, you can enable the immediate leave function.

Command Usage

- One or more interfaces may be configured as MVR source ports.
- MVR receiver ports cannot be members of a trunk. Receiver ports can belong to different VLANs, but should not be configured as a member of the MVR VLAN.
- IGMP snooping can be used to allow a source port or receiver port to dynamically join or leave multicast groups within the MVR VLAN using the standard rules for multicast filtering. Multicast groups can also be statically assigned to a source port or receiver port (see “Assigning Static Multicast Groups to Interfaces” on page 3-233).

3 Configuring the Switch

- Immediate leave applies only to receiver ports. When enabled, the receiver port is immediately removed from the multicast group identified in the leave message. When immediate leave is disabled, the switch follows the standard rules by sending a group-specific query to the receiver port and waiting for a response to determine if there are any remaining subscribers for that multicast group before removing the port from the group list. Using immediate leave can speed up leave latency, but should only be enabled on a port attached to one multicast subscriber to avoid disrupting services to other group members attached to the same interface. Note that immediate leave does not apply to multicast groups which have been statically assigned to a port.

Command Attributes

- **MVR Type** – The following interface types are supported:
 - Source – An uplink port that can send and receive multicast data for the groups assigned to the MVR VLAN.
 - Receiver – A subscriber port that can receive multicast data sent through the MVR VLAN.
 - Non-MVR – An interface that does not participate in the MVR VLAN. (This is the default type.)
- **Immediate Leave** – Configures the switch to immediately remove an interface from a multicast stream as soon as it receives a leave message for that group.
- **Trunk**¹⁶ – Shows if port is a trunk member.

Web – Click MVR, Port or Trunk Configuration.

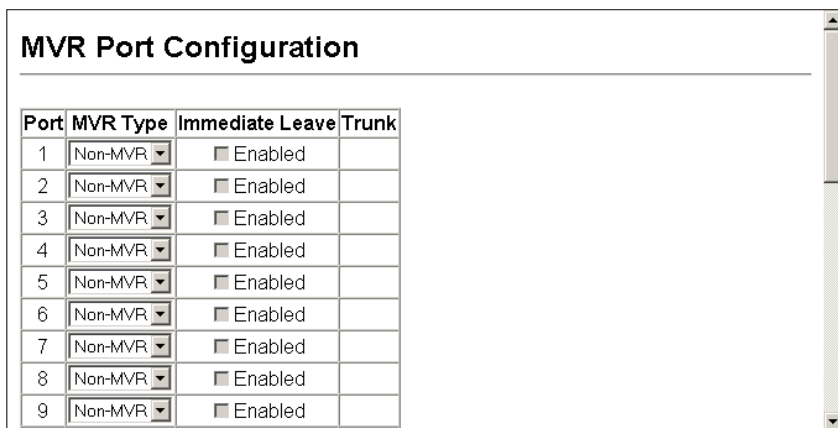

Port	MVR Type	Immediate Leave	Trunk
1	Non-MVR	<input type="checkbox"/> Enabled	
2	Non-MVR	<input type="checkbox"/> Enabled	
3	Non-MVR	<input type="checkbox"/> Enabled	
4	Non-MVR	<input type="checkbox"/> Enabled	
5	Non-MVR	<input type="checkbox"/> Enabled	
6	Non-MVR	<input type="checkbox"/> Enabled	
7	Non-MVR	<input type="checkbox"/> Enabled	
8	Non-MVR	<input type="checkbox"/> Enabled	
9	Non-MVR	<input type="checkbox"/> Enabled	

Figure 3-143 MVR Port Configuration

¹⁶. Port Information only.

CLI – This example configures an MVR source port and receiver port, and then enables immediate leave on the receiver port.

```

Console(config)#interface ethernet 1/1
Console(config-if)#mvr type source                               4-305
Console(config-if)#exit
Console(config)#interface ethernet 1/2
Console(config-if)#mvr type receiver                             4-305
Console(config-if)#mvr immediate                                4-305
Console(config-if)#

```

Assigning Static Multicast Groups to Interfaces

For multicast streams that will run for a long term and be associated with a stable set of hosts, you can statically bind the multicast group to the participating interfaces.

Command Usage

- Any multicast groups that use the MVR VLAN must be statically assigned to it under the MVR Configuration menu (see “Configuring Global MVR Settings” on page 3-228).
- The IP address range from 224.0.0.0 to 239.255.255.255 is used for multicast streams. MVR group addresses cannot fall within the reserved IP multicast address range of 224.0.0.x.

Command Attributes

- **Interface** – Indicates a port or trunk.
- **Member** – Shows the IP addresses for MVR multicast groups which have been statically assigned to the selected interface.
- **Non-Member** – Shows the IP addresses for all MVR multicast groups which have not been statically assigned to the selected interface.

Web – Click MVR, Group Member Configuration. Select a port or trunk from the “Interface” field, and click Query to display the assigned multicast groups. Select a multicast address from the displayed lists, and click the Add or Remove button to modify the Member list.

MVR Static Group Member

Interface: Port 1 Trunk

Member: (none) Non-Member: (none)

Figure 3-144 MVR Group Member Configuration

3 Configuring the Switch

CLI – This example statically assigns a multicast group to a receiver port.

```
Console(config)#interface ethernet 1/2
Console(config-if)#mvr group 228.1.23.1
Console(config-if)#
```

4-305

DHCP Snooping

DHCP snooping allows a switch to protect a network from rogue DHCP servers or other devices which send port-related information to a DHCP server. This information can be useful in tracking an IP address back to a physical port.

Network traffic may be disrupted when malicious DHCP messages are received from an outside source. DHCP snooping is used to filter DHCP messages received on a non-secure interface from outside the network or firewall. When DHCP snooping is enabled globally and enabled on a VLAN interface, DHCP messages received on an untrusted interface from a device not listed in the DHCP snooping table will be dropped.

When enabled, DHCP messages entering an untrusted interface are filtered based upon dynamic entries learned via DHCP snooping.

Filtering rules are implemented as follows:

- If the global DHCP snooping is disabled, all DHCP packets are forwarded.
- If DHCP snooping is enabled globally, and also enabled on the VLAN where the DHCP packet is received, all DHCP packets are forwarded for a *trusted* port. If the received packet is a DHCP ACK message, a dynamic DHCP snooping entry is also added to the binding table.
- If DHCP snooping is enabled globally, and also enabled on the VLAN where the DHCP packet is received, but the port is *not trusted*, it is processed as follows:
 - If the DHCP packet is a reply packet from a DHCP server (including OFFER, ACK or NAK messages), the packet is dropped.
 - If the DHCP packet is from a client, such as a DECLINE or RELEASE message, the switch forwards the packet only if the corresponding entry is found in the binding table.
 - If the DHCP packet is from a client, such as a DISCOVER, REQUEST, INFORM, DECLINE or RELEASE message, the packet is forwarded if MAC address verification is disabled. However, if MAC address verification is enabled, then the packet will only be forwarded if the client's hardware address stored in the DHCP packet is the same as the source MAC address in the Ethernet header.
 - If the DHCP packet is not a recognizable type, it is dropped.
- If a DHCP packet from a client passes the filtering criteria above, it will only be forwarded to trusted ports in the same VLAN.
- If a DHCP packet is from server is received on a trusted port, it will be forwarded to both trusted and untrusted ports in the same VLAN.

If the DHCP snooping is globally disabled, all dynamic bindings are removed from the binding table.

Additional considerations when the switch itself is a DHCP client – The port(s) through which the switch submits a client request to the DHCP server must be configured as trusted. Note that the switch will not add a dynamic entry for itself to the binding table when it receives an ACK message from a DHCP server. Also, when the switch sends out DHCP client packets for itself, no filtering takes place. However, when the switch receives any messages from a DHCP server, any packets received from untrusted ports are dropped.

DHCP Snooping Configuration

Command Attributes

- **DHCP Snooping Status** – Enables or disables DHCP snooping globally.
- **DHCP Snooping MAC-Address Verification** – Enables or disables MAC address verification. DHCP packets will be dropped if the source MAC address in the Ethernet header of the packet is not same as the client's hardware address in the DHCP packet.

Web – Click DHCP Snooping, Configuration.

DHCP Snooping Configuration

DHCP Snooping Status	<input type="checkbox"/> Enabled
DHCP Snooping MAC-Address Verification	<input checked="" type="checkbox"/> Enabled

Figure 3-145 DHCP Snooping Configuration

CLI – This example first enables DHCP Snooping, and then enables DHCP Snooping MAC-Address Verification.

```

Console(config)#ip dhcp snooping           4-317
Console(config)#ip dhcp snooping verify mac-address 4-321
Console(config)#

```

DHCP Snooping VLAN Configuration

Enables DHCP snooping on the specified VLAN.

Command Attributes

- **VLAN ID** – ID of a configured VLAN. (Range: 1-4093)
- **DHCP Snooping Status** – Enables or disables DHCP snooping for the selected VLAN. When DHCP snooping is enabled globally on the switch, and enabled on the specified VLAN, DHCP packet filtering will be performed on any untrusted ports within the VLAN.

3 Configuring the Switch

Web – Click DHCP Snooping, VLAN Configuration.

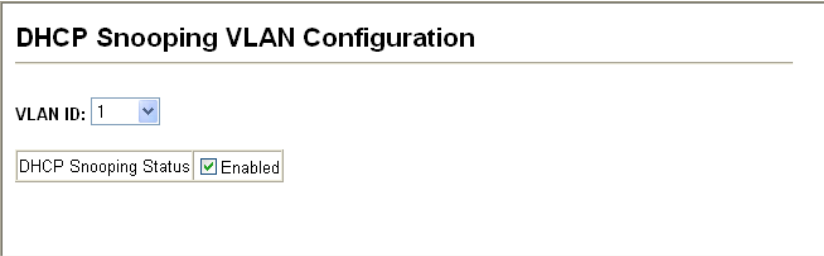

DHCP Snooping VLAN Configuration

VLAN ID: 1

DHCP Snooping Status Enabled

Figure 3-146 DHCP Snooping VLAN Configuration

CLI – This example first enables DHCP Snooping for VLAN 1.

```
Console(config)#ip dhcp snooping vlan 1  
Console(config)#
```

4-319

DHCP Snooping Information Option Configuration

DHCP provides a relay mechanism for sending information about the switch and its DHCP clients to the DHCP server. Known as DHCP Option 82, it allows compatible DHCP servers to use the information when assigning IP addresses, or to set other services or policies for clients.

When the DHCP Snooping Information Option is enabled, clients can be identified by the switch port to which they are connected rather than just their MAC address. DHCP client-server exchange messages are then forwarded directly between the server and client without having to flood them to the entire VLAN.

In some cases, the switch may receive DHCP packets from a client that already includes DHCP Option 82 information. The switch can be configured to set the action policy for these packets. Either the switch can drop the DHCP packets, keep the existing information, or replace it with the switch's relay information.

Note: DHCP snooping must be enabled on the switch for the DHCP Option 82 information to be inserted into packets.

Command Attributes

- **DHCP Snooping Information Option Status** – Enables or disables DHCP Option 82 information relay.
- **DHCP Snooping Information Option Policy** – Sets the DHCP snooping information option policy for DHCP client packets that include Option 82 information.
 - **Replace** – Overwrites the DHCP client packet information with the switch's relay information.
 - **Keep** – Retains the client's DHCP information.
 - **Drop** – Discards the Option 82 information in a packet and then floods it to the entire VLAN.

Web – Click DHCP Snooping, Information Option Configuration.

DHCP Snooping Information Option Configuration

DHCP Snooping Information Option Status	<input type="checkbox"/> Enabled
DHCP Snooping Information Option Policy	Replace ▾

Figure 3-147 DHCP Snooping Information Option Configuration

CLI – This example enables DHCP Snooping Information Option, and sets the policy as replace.

```

Console(config)#ip dhcp snooping information option      4-321
Console(config)#ip dhcp snooping information policy replace  4-322
Console(config)#
  
```

DHCP Snooping Port Configuration

Configures switch ports as trusted or untrusted. An untrusted interface is an interface that is configured to receive messages from outside the network or firewall. A trusted interface is an interface that is configured to receive only messages from within the network.

Command Attributes

- **Trust Status** – Enables or disables port as trusted.

Web – Click DHCP Snooping, Information Option Configuration.

DHCP Snooping Port Configuration

Port	Trust Status
1	<input type="checkbox"/> Enabled
2	<input type="checkbox"/> Enabled
3	<input type="checkbox"/> Enabled
4	<input type="checkbox"/> Enabled
5	<input type="checkbox"/> Enabled
6	<input type="checkbox"/> Enabled
7	<input type="checkbox"/> Enabled
8	<input type="checkbox"/> Enabled
9	<input type="checkbox"/> Enabled

Figure 3-148 DHCP Snooping Port Configuration

3 Configuring the Switch

CLI – This example shows how to enable the DHCP Snooping Trust Status for ports.

```
Console(config)#interface ethernet 1/5
Console(config-if)#ip dhcp snooping trust
Console(config-if)#
```

4-320

DHCP Snooping Binding Information

Displays the DHCP snooping binding information.

Command Attributes

- **No.** – Entry number for DHCP snooping binding information.
- **Unit** – Stack unit.
- **Port** – Port number.
- **VLAN ID** – ID of a configured VLAN (Range: 1-4093)
- **MAC Address** – A valid unicast MAC address.
- **IP Address** – A valid unicast IP address.
- **IP Address Type** – Indicates an IPv4 or IPv6 address type.
- **Lease Time (Seconds)** – The time after which an entry is removed from the table.

Web – Click DHCP Snooping, DHCP Snooping Binding Information.

DHCP Snooping Binding Information

Store DHCP snooping binding entry to flash.

No.	Unit	Port	VLAN ID	MAC Address	IP Address	IP Address Type	Lease Time (Seconds)
-----	------	------	---------	-------------	------------	-----------------	----------------------

Figure 3-149 DHCP Snooping Binding Information

CLI – This example shows how to display the DHCP Snooping binding table entries.

```
Console#show ip dhcp snooping binding
MacAddress      IpAddress      Lease(sec)  Type           VLAN  Interface
-----
11-22-33-44-55-66  192.168.0.99          0 Dynamic             1    Eth 1/5
Console#
```

4-324

IP Source Guard

IP Source Guard is a security feature that filters IP traffic on network interfaces based on manually configured entries in the IP Source Guard table, or static and dynamic entries in the DHCP Snooping table when enabled (see “DHCP Snooping” on page 3-234). IP source guard can be used to prevent traffic attacks caused when a host tries to use the IP address of a neighbor to access the network. This section describes commands used to configure IP Source Guard.

IP Source Guard Port Configuration

IP Source Guard is used to filter traffic on an unsecure port which receives messages from outside the network or firewall, and therefore may be subject to traffic attacks caused by a host trying to use the IP address of a neighbor.

When enabled, traffic is filtered based upon dynamic entries learned via DHCP snooping or static addresses configured in the source guard binding table. An inbound packet's IP address (sip option) or both its IP address and corresponding MAC address (sip-mac option) are checked against the binding table. If no matching entry is found, the packet is dropped.

Command Attributes

- **Filter Type** – Configures the switch to filter inbound traffic based source IP address, or source IP address and corresponding MAC address. (Default: None)
 - **None** – Disables IP source guard filtering on the port.
 - **SIP** – Enables traffic filtering based on IP addresses stored in the binding table.
 - **SIP-MAC** – Enables traffic filtering based on IP addresses and corresponding MAC addresses stored in the binding table.

Web – Click IP Source Guard, Port Configuration.

Port	Filter Type
1	None
2	None
3	None
4	None
5	None
6	None
7	None
8	None

Figure 3-150 IP Source Guard Port Configuration

3 Configuring the Switch

CLI – This example shows how to enable IP source guard on port 5.

```
Console(config)#interface ethernet 1/5
Console(config-if)#ip source-guard sip           4-313
Console(config-if)#end
Console#show ip source-guard                    4-316
Interface   Filter-type
-----
Eth 1/1     DISABLED
Eth 1/2     DISABLED
Eth 1/3     DISABLED
Eth 1/4     DISABLED
Eth 1/5     SIP
Eth 1/6     DISABLED
:
```

Static IP Source Guard Binding Configuration

Adds a static addresses to the source-guard binding table. Table entries include a MAC address, IP address, lease time, entry type (Static, Dynamic), VLAN identifier, and port identifier. All static entries are configured with an infinite lease time, which is indicated with a value of zero in the table.

Command Attributes

- **Static Binding Table Counts** – The total number of static entries in the table.
- **Port** – Switch port number. (Range: 1-28/52)
- **VLAN ID** – ID of a configured VLAN (Range: 1-4093)
- **MAC Address** – A valid unicast MAC address.
- **IP Address** – A valid unicast IP address, including classful types A, B or C.

Web – Click IP Source Guard, Static Configuration.

Static IP Source Guard Binding Configuration

Static Binding Table Counts	<input type="text" value="1"/>
Current Static Binding Table	VLAN 1, 00-12-34-56-78-9A, Unit 1, Port 9, 192.168.1.35, IPv4, Lease Time 0 Seconds
Port	<input type="text" value="1"/> ▼
VLAN ID	<input type="text" value="1"/> ▼
MAC Address (XX-XX-XX-XX-XX-XX)	<input type="text"/>
IP Address	<input type="text"/>

Figure 3-151 Static IP Source Guard Binding Configuration

CLI – This example shows how to configure a static source-guard binding on port 5.

```

Console(config)#ip source-guard binding 11-22-33-44-55-66 vlan 1
192.168.0.99 interface ethernet 1/5
Console(config)#
  
```

Dynamic IP Source Guard Binding Information

Displays the source-guard binding table for a selected interface.

Command Attributes

- **Query by** – Select an interface to display the source-guard binding. (Options: Port, VLAN, MAC Address, or IP Address)
- **Dynamic Binding Table Counts** – Displays the number of IP addresses in the source-guard binding table.
- **Current Dynamic Binding Table** – Displays the IP addresses in the source-guard binding table.

3 Configuring the Switch

Web – Click IP Source Guard, Dynamic Information.

Dynamic IP Source Guard Binding Information

Query by:	
<input type="checkbox"/> Port	1
<input type="checkbox"/> VLAN	1
<input type="checkbox"/> MAC Address	
<input type="checkbox"/> IP Address	
<input type="button" value="Query"/>	
Dynamic IP Source Guard Binding Table	
Dynamic Binding Table Counts	0
Current Dynamic Binding Table	(none)

Figure 3-152 Dynamic IP Source Guard Binding Information

CLI – This example shows how to configure a static source-guard binding on port 5.

```
Console#show ip source-guard binding 4-316
MacAddress      IpAddress      Lease(sec)  Type           VLAN
Interface
-----
11-22-33-44-55-66 192.168.0.99      0 Static        1 Eth 1/5
Console#
```

Switch Clustering

Switch Clustering is a method of grouping switches together to enable centralized management through a single unit. Switches that support clustering can be grouped together regardless of physical location or switch type, as long as they are connected to the same local network.

A switch cluster has a “Commander” unit that is used to manage all other “Member” switches in the cluster. The management station can use both Telnet and the web interface to communicate directly with the Commander through its IP address, while the Commander manages Member switches using cluster “internal” IP addresses. There can be up to 36 Member switches in one cluster, and Cluster switches must be in the same IP subnet.

Once a switch has been configured to be a cluster Commander, it automatically discovers other cluster-enabled switches in the network. These “Candidate”

switches only become cluster Members when manually selected by the administrator through the management station.

After the Commander and Members have been configured, any switch in the cluster can be managed from the web agent by choosing the desired Member ID from the Cluster drop down menu. From the Commander CLI prompt, use the “rcommand” command (see page 4-327) to connect to the Member switch.

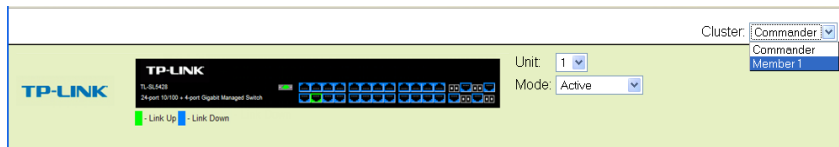

Figure 3-153 Cluster Member Choice

Cluster Configuration

To create a switch cluster, first be sure that clustering is enabled on the switch (the default is enabled), then set the switch as a Cluster Commander. Set a Cluster IP Pool that does not conflict with the network IP subnet. Cluster IP addresses are assigned to switches when they become Members and are used for communication between Member switches and the Commander.

Command Attributes

- **Cluster Status** – Enables or disables clustering on the switch. (Default: Enabled)
- **Cluster Commander** – Enables or disables the switch as a cluster Commander.
- **Role** – Indicates the current role of the switch in the cluster; either Commander, Member, or Candidate.
- **Cluster IP Pool** – An “internal” IP address pool that is used to assign IP addresses to Member switches in the cluster. Internal cluster IP addresses are in the form *10.x.x.member-ID*. Only the base IP address of the pool needs to be set since Member IDs can only be between 1 and 36. Note that you cannot change the cluster IP pool when the switch is currently in Commander mode. Commander mode must first be disabled. (Default: 10.254.254.1)
- **Number of Members** – The current number of Member switches in the cluster.
- **Number of Candidates** – The current number of Candidate switches discovered in the network that are available to become Members.

3 Configuring the Switch

Web – Click Cluster, Configuration.

Cluster Configuration	
Cluster Status	<input checked="" type="checkbox"/> Enabled
Cluster Commander	<input checked="" type="checkbox"/> Enabled
Role	Commander
Cluster IP Pool	10.254.254.1
Number of Members	1
Number of Candidates	2

Figure 3-154 Cluster Configuration

CLI – This example first enables clustering on the switch, sets the switch as the cluster Commander, and then configures the cluster IP pool.

```
Console(config)#cluster 4-324
Console(config)#cluster commander 4-325
Console(config)#cluster ip-pool 10.2.3.4 4-326
Console(config)#
```

Cluster Member Configuration

Adds Candidate switches to the cluster as Members.

Command Attributes

- **Member ID** – Specify a Member ID number for the selected Candidate switch. (Range: 1-36)
- **MAC Address** – Select a discovered switch MAC address from the Candidate Table, or enter a specific MAC address of a known switch.

Web – Click Cluster, Member Configuration.

Figure 3-155 Cluster Member Configuration

CLI – This example creates a new cluster Member by specifying the Candidate switch MAC address and setting a Member ID.

```
Console(config)#cluster member mac-address 00-12-34-56-78-9a id 5 4-326
Console(config)#
```

Cluster Member Information

Displays current cluster Member switch information.

Command Attributes

- **Member ID** – The ID number of the Member switch. (Range: 1-36)
- **Role** – Indicates the current status of the switch in the cluster.
- **IP Address** – The internal cluster IP address assigned to the Member switch.
- **MAC Address** – The MAC address of the Member switch.
- **Description** – The system description string of the Member switch.

Web – Click Cluster, Member Information.

Member ID	Role	IP Address	MAC Address	Description
1	Active Member	10.254.254.2	00-12-CF-23-49-C0	24/48 L2/L4 IPV4/IPV6 GE Switch

Figure 3-156 Cluster Member Information

3 Configuring the Switch

CLI – This example shows information about cluster Member switches.

```
Vty-0#show cluster members 4-328
Cluster Members:
ID:          1
Role:        Active member
IP Address:  10.254.254.2
MAC Address: 00-12-cf-23-49-c0
Description: 24/48 L2/L4 IPV4/IPV6 GE Switch
Vty-0#
```

Cluster Candidate Information

Displays information about discovered switches in the network that are already cluster Members or are available to become cluster Members.

Command Attributes

- **Role** – Indicates the current status of Candidate switches in the network.
- **MAC Address** – The MAC address of the Candidate switch.
- **Description** – The system description string of the Candidate switch.

Web – Click Cluster, Candidate Information.

Cluster Candidate Information

Clear cluster candidate table.

Role	MAC Address	Description
Active Member	00-12-CF-23-49-C0	24/48 L2/L4 IPV4/IPV6 GE Switch
Candidate	00-12-CF-0B-47-AD	24/48 L2/L4 IPV4/IPV6 GE Switch

Figure 3-157 Cluster Candidate Information

CLI – This example shows information about cluster Candidate switches.

```
Vty-0#show cluster candidates 4-328
Cluster Candidates:
Role           Mac           Description
-----
ACTIVE MEMBER 00-12-cf-23-49-c0 24/48 L2/L4 IPV4/IPV6 GE Switch
CANDIDATE     00-12-cf-0b-47-a0 24/48 L2/L4 IPV4/IPV6 GE Switch
Vty-0#
```

UPnP

Universal Plug and Play (UPnP) is a set of protocols that allows devices to connect seamlessly and simplifies the deployment of home and office networks. UPnP achieves this by issuing UPnP device control protocols designed upon open, Internet-based communication standards.

The first step in UPnP networking is discovery. When a device is added to the network, the UPnP discovery protocol allows that device to broadcast its services to control points on the network. Similarly, when a control point is added to the network, the UPnP discovery protocol allows that control point to search for UPnP enabled devices on the network.

Once a control point has discovered a device its next step is to learn more about the device and its capabilities by retrieving the device's description from the URL provided by the device in the discovery message. After a control point has retrieved a description of the device, it can send actions to the device's service. To do this, a control point sends a suitable control message to the control URL for the service (provided in the device description).

When a device is known to the control point, periodic event notification messages are sent. A UPnP description for a service includes a list of actions the service responds to and a list of variables that model the state of the service at run time.

If a device has a URL for presentation, then the control point can retrieve a page from this URL, load the page into a web browser, and depending on the capabilities of the page, allow a user to control the device and/or view device status.

UPnP Configuration

This page allows you to enable or disable UPnP, and to set time out values.

Command Attributes

- **UPNP Status** – Enables/disables UPnP on the device.
- **Advertising Duration** – This sets the duration of which a device will advertise its status to the control point. (Range: 60-86400 seconds; Default: 100 seconds)
- **TTL Value** – Sets the time-to-live (TTL) value for UPnP messages transmitted by the device. (Range: 1-255; Default: 4)

Web – Click UPNP, Configuration and enter the desired variables

UPNP Configuration

UPNP Status	<input checked="" type="checkbox"/> Enabled
Advertising Duration (60-86400)	<input type="text" value="100"/> seconds
TTL Value(1-255)	<input type="text" value="4"/>

Figure 3-158 UPnP Configuration

3 Configuring the Switch

CLI – This example enables UPnP, sets the device advertise duration to 200 seconds, the device TTL to 6, and displays information about basic UPnP configuration.

```
Console(config)#upnp device 4-215
Console(config)#upnp device advertise duration 200 4-216
Console(config)#upnp device ttl 6 4-216
Console(config)#end
Console#sh upnp 4-217
UPnP global settings:
  Status: Enabled
  Advertise duration: 200
  TTL: 6
Console#
```

Chapter 4: Command Line Interface

This chapter describes how to use the Command Line Interface (CLI).

Using the Command Line Interface

Accessing the CLI

When accessing the management interface for the switch over a direct connection to the server's console port, or via a Telnet connection, the switch can be managed by entering command keywords and parameters at the prompt. Using the switch's command-line interface (CLI) is very similar to entering commands on a UNIX system.

Console Connection

To access the switch through the console port, perform these steps:

1. At the console prompt, enter the user name and password. (The default user names are "admin" and "guest" with corresponding passwords of "admin" and "guest.") When the administrator user name and password is entered, the CLI displays the "Console#" prompt and enters privileged access mode (i.e., Privileged Exec). But when the guest user name and password is entered, the CLI displays the "Console>" prompt and enters normal access mode (i.e., Normal Exec).
2. Enter the necessary commands to complete your desired tasks.
3. When finished, exit the session with the "quit" or "exit" command.

After connecting to the system through the console port, the login screen displays:

```
User Access Verification
Username: admin
Password:

    CLI session with the TL-SL5428 is opened.
    To end the CLI session, enter [Exit].

Console#
```

Telnet Connection

Telnet operates over the IP transport protocol. In this environment, your management station and any network device you want to manage over the network must have a valid IP address. Valid IP addresses consist of four numbers, 0 to 255, separated by periods. Each address consists of a network portion and host portion. For example, the IP address assigned to this switch, 10.1.0.1, with subnet mask 255.255.255.0, consists of a network portion (10.1.0) and a host portion (1).

Note: The IP address for this switch is obtained via DHCP by default.

To access the switch through a Telnet session, you must first set the IP address for the Master unit, and set the default gateway if you are managing the switch from a different IP subnet. For example,

```
Console(config)#interface vlan 1
Console(config-if)#ip address 10.1.0.254 255.255.255.0
Console(config-if)#exit
Console(config)#ip default-gateway 10.1.0.254
```

If your corporate network is connected to another network outside your office or to the Internet, you need to apply for a registered IP address. However, if you are attached to an isolated network, then you can use any IP address that matches the network segment to which you are attached.

After you configure the switch with an IP address, you can open a Telnet session by performing these steps:

1. From the remote host, enter the Telnet command and the IP address of the device you want to access.
2. At the prompt, enter the user name and system password. The CLI will display the “Vty-*n*#” prompt for the administrator to show that you are using privileged access mode (i.e., Privileged Exec), or “Vty-*n*>” for the guest to show that you are using normal access mode (i.e., Normal Exec), where *n* indicates the number of the current Telnet session.
3. Enter the necessary commands to complete your desired tasks.
4. When finished, exit the session with the “quit” or “exit” command.

After entering the Telnet command, the login screen displays:

```
Username: admin
Password:

      CLI session with the TL-SL5428 is opened.
      To end the CLI session, enter [Exit].

Vty-0#
```

Note: You can open up to four sessions to the device via Telnet.

Entering Commands

This section describes how to enter CLI commands.

Keywords and Arguments

A CLI command is a series of keywords and arguments. Keywords identify a command, and arguments specify configuration parameters. For example, in the command “show interfaces status ethernet 1/5,” **show interfaces** and **status** are keywords, **ethernet** is an argument that specifies the interface type, and **1/5** specifies the unit/port.

You can enter commands as follows:

- To enter a simple command, enter the command keyword.
- To enter multiple commands, enter each command in the required order. For example, to enable Privileged Exec command mode, and display the startup configuration, enter:

```
Console>enable
Console#show startup-config
```

- To enter commands that require parameters, enter the required parameters after the command keyword. For example, to set a password for the administrator, enter:

```
Console(config)#username admin password 0 smith
```

Minimum Abbreviation

The CLI will accept a minimum number of characters that uniquely identify a command. For example, the command “configure” can be entered as **con**. If an entry is ambiguous, the system will prompt for further input.

Command Completion

If you terminate input with a Tab key, the CLI will print the remaining characters of a partial keyword up to the point of ambiguity. In the “logging history” example, typing **log** followed by a tab will result in printing the command up to “**logging**.”

Getting Help on Commands

You can display a brief description of the help system by entering the **help** command. You can also display command syntax by using the “?” character to list keywords or parameters.

Showing Commands

If you enter a “?” at the command prompt, the system will display the first level of keywords for the current command class (Normal Exec or Privileged Exec) or configuration class (Global, ACL, Interface, Line or VLAN Database). You can also display a list of valid keywords for a specific command. For example, the command “**show ?**” displays a list of possible show commands.

```
Console#show ?
access-group      Access groups
access-list       Access lists
accounting        Uses an accounting list with this name
banner            Banner info
bridge-ext        Bridge extension information
calendar          Date and time information
class-map         Displays class maps
cluster           Display cluster
dot1q-tunnel      dot1q-tunnel
dot1x             802.1x content
garp              GARP properties
gvrp              GVRP interface information
history           History information
interfaces        Interface information
ip                IP information
lacp              LACP statistics
line              TTY line information
lldp              LLDP
log               Login records
logging           Logging setting
mac               MAC access list
mac-address-table Shows the MAC address table
management        Show management information
map               Maps priority
memory            Memory utilization
mvr               Shows MVR global parameters
network-access    Shows the entries of the secure port.
ntp               Network Time Protocol configuration
policy-map        Displays policy maps
port              Port characteristics
privilege         Shows current privilege level
process           Device process
protocol-vlan     Protocol-VLAN information
public-key        Public key information
queue             Priority queue information
radius-server     RADIUS server information
reload            Shows the reload settings
running-config    Information on the running configuration
snmp              Simple Network Management Protocol statistics
sntp              Simple Network Time Protocol configuration
spanning-tree     Spanning-tree configuration
ssh               Secure shell server connections
startup-config    Startup system configuration
system            System information
tacacs-server     TACACS server settings
upnp              UPnP settings
users             Information about terminal lines
version           System hardware and software versions
vlan              Virtual LAN settings
voice             Shows the voice VLAN information
web-auth          Shows web authentication configuration
Console#show
```

4 Command Line Interface

The command “**show interfaces ?**” will display the following information:

```
Console#show interfaces ?
  counters      Interface counters information
  status        Interface status information
  switchport    Interface switchport information
Console#show interfaces
```

Partial Keyword Lookup

If you terminate a partial keyword with a question mark, alternatives that match the initial letters are provided. (Remember not to leave a space between the command and question mark.) For example “**s?**” shows all the keywords starting with “s.”

```
Console#show s?
snmp          snmp          spanning-tree  ssh          startup-config
system
Console#show s
```

Negating the Effect of Commands

For many configuration commands you can enter the prefix keyword “**no**” to cancel the effect of a command or reset the configuration to the default value. For example, the **logging** command will log system messages to a host server. To disable logging, specify the **no logging** command. This guide describes the negation effect for all applicable commands.

Using Command History

The CLI maintains a history of commands that have been entered. You can scroll back through the history of commands by pressing the up arrow key. Any command displayed in the history list can be executed again, or first modified and then executed.

Using the **show history** command displays a longer list of recently executed commands.

Understanding Command Modes

The command set is divided into Exec and Configuration classes. Exec commands generally display information on system status or clear statistical counters. Configuration commands, on the other hand, modify interface parameters or enable certain switching functions. These classes are further divided into different modes. Available commands depend on the selected mode. You can always enter a question mark “**?**” at the prompt to display a list of the commands available for the

current mode. The command classes and associated modes are displayed in the following table:

Table 4-1 Command Modes

Class	Mode	
Exec	Normal Privileged	
Configuration	Global*	Access Control List Class Map Interface Line Multiple Spanning Tree Policy Map Server Group VLAN Database

* You must be in Privileged Exec mode to access the Global configuration mode.
You must be in Global Configuration mode to access any of the other configuration modes.

Exec Commands

When you open a new console session on the switch with the user name and password “guest,” the system enters the Normal Exec command mode (or guest mode), displaying the “Console>” command prompt. Only a limited number of the commands are available in this mode. You can access all commands only from the Privileged Exec command mode (or administrator mode). To access Privilege Exec mode, open a new console session with the user name and password “admin.” The system will now display the “Console#” command prompt. You can also enter Privileged Exec mode from within Normal Exec mode, by entering the **enable** command, followed by the privileged level password “super” (page 4-38).

To enter Privileged Exec mode, enter the following user names and passwords:

```
Username: admin
Password: [admin login password]

      CLI session with the TL-SL5428 is opened.
      To end the CLI session, enter [Exit].

Console#
```

```
Username: guest
Password: [guest login password]

      CLI session with the TL-SL5428 is opened.
      To end the CLI session, enter [Exit].

Console>enable
Password: [privileged level password]
Console#
```

Configuration Commands

Configuration commands are privileged level commands used to modify switch settings. These commands modify the running configuration only and are not saved when the switch is rebooted. To store the running configuration in non-volatile storage, use the **copy running-config startup-config** command.

The configuration commands are organized into different modes:

- Global Configuration - These commands modify the system level configuration, and include commands such as **hostname** and **snmp-server community**.
- Access Control List Configuration - These commands are used for packet filtering.
- Interface Configuration - These commands modify the port configuration such as **speed-duplex** and **negotiation**.
- Line Configuration - These commands modify the console port and Telnet configuration, and include command such as **parity** and **databits**.
- VLAN Configuration - Includes the command to create VLAN groups.

To enter the Global Configuration mode, enter the command **configure** in Privileged Exec mode. The system prompt will change to “Console(config)#” which gives you access privilege to all Global Configuration commands.

```
Console#configure
Console(config)#
```

To enter the other modes, at the configuration prompt type one of the following commands. Use the **exit** or **end** command to return to the Privileged Exec mode.

Table 4-2 Configuration Modes

Mode	Command	Prompt	Page
Line	line {console vty}	Console(config-line)#	4-11
Access Control List	access-list ip standard access-list ip extended access-list mac	Console(config-std-acl) Console(config-ext-acl) Console(config-mac-acl)	4-138 4-140 4-145
Class Map	class map	Console(config-cmap)	4-198
Interface	interface {ethernet port port-channel id} vlan id}	Console(config-if)#	4-120
MSTP	spanning-tree mst-configuration	Console(config-mstp)#	4-154
Policy Map	policy map	Console(config-pmap)	4-200
Server Group	aaa group server {radius tacacs+}	Console(config-sg-radius)# Console(config-sg-tacacs+)	4-101
VLAN	vlan database	Console(config-vlan)	4-167

For example, you can use the following commands to enter interface configuration mode, and then return to Privileged Exec mode

```
Console(config)#interface ethernet 1/5
:
:
Console(config-if)#exit
Console(config)#
```

Command Line Processing

Commands are not case sensitive. You can abbreviate commands and parameters as long as they contain enough letters to differentiate them from any other currently available commands or parameters. You can use the Tab key to complete partial commands, or enter a partial command followed by the “?” character to display a list of possible matches. You can also use the following editing keystrokes for command-line processing:

Table 4-3 Command Line Processing

Keystroke	Function
Ctrl-A	Shifts cursor to start of command line.
Ctrl-B	Shifts cursor to the left one character.
Ctrl-C	Terminates the current task and displays the command prompt.
Ctrl-E	Shifts cursor to end of command line.
Ctrl-F	Shifts cursor to the right one character.
Ctrl-K	Deletes all characters from the cursor to the end of the line.
Ctrl-L	Repeats current command line on a new line.
Ctrl-N	Enters the next command line in the history buffer.
Ctrl-P	Enters the last command.
Ctrl-R	Repeats current command line on a new line.
Ctrl-U	Deletes from the cursor to the beginning of the line.
Ctrl-W	Deletes the last word typed.
Esc-B	Moves the cursor back one word.
Esc-D	Deletes from the cursor to the end of the word.
Esc-F	Moves the cursor forward one word.
Delete key or backspace key	Erases a mistake when entering a command.

Command Groups

The system commands can be broken down into the functional groups shown below.

Table 4-4 Command Groups

Command Group	Description	Page
Line	Sets communication parameters for the serial port and Telnet, including baud rate and console time-out	4-11
General	Basic commands for entering privileged access mode, restarting the system, or quitting the CLI	4-20
System Management	Controls system logs, system passwords, user name, browser management options, and a variety of other system information	4-26
Flash/File	Manages code image or switch configuration files	4-84
Authentication	Configures AAA security and other network access controls	4-90
Access Control List	Provides filtering for IP frames (based on address, protocol, or TCP/UDP port number) or non-IP frames (based on MAC address or Ethernet type)	4-138
SNMP	Activates authentication failure traps; configures community access strings, and trap managers; also configures IP address filtering	4-149
Interface	Configures the connection parameters for all Ethernet ports, aggregated links, and VLANs	4-166
Mirror Port	Mirrors data to another port for analysis without affecting the data passing through or the performance of the monitored port	4-177
Rate Limiting	Controls the maximum rate for traffic transmitted or received on a port	4-179
Link Aggregation	Statically groups multiple ports into a single logical trunk; configures Link Aggregation Control Protocol for port trunks	4-180
Address Table	Configures the address table for filtering specified addresses, displays current entries, clears the table, or sets the aging time	4-190
Spanning Tree	Configures Spanning Tree settings for the switch	4-217
VLANs	Configures VLAN settings, and defines port membership for VLAN groups; also enables or configures private VLANs and protocol VLANs	4-238
LLDP	Configures LLDP settings to enable information discovery about neighbor devices	4-193
Class of Service	Sets port priority for untagged frames, selects strict priority or weighted round robin, relative weight for each priority queue, also sets priority for TCP/UDP traffic types, and DSCP	4-264
Quality of Service	Configures Differentiated Services	4-197
Voice VLAN	Configures VoIP traffic detection and enables a Voice VLAN	4-280
Multicast Filtering	Configures IGMP multicast filtering, query parameters, specifies ports attached to a multicast router, and enables multicast VLAN registration	4-287
IP Interface	Configures IP address for the switch	4-309
DHCP Snooping	Configures DHCP snooping	4-317
IP Source Guard	Configures IP source guard security	4-313

Table 4-4 Command Groups (Continued)

Command Group	Description	Page
IP Cluster	Configures switch clustering	4-324
UPnP	Configures UPnP settings	4-324

The access mode shown in the following tables is indicated by these abbreviations:

ACL (Access Control List Configuration)	MST (Multiple Spanning Tree)
CM (Class Map Configuration)	NE (Normal Exec)
GC (Global Configuration)	PE (Privileged Exec)
IC (Interface Configuration)	PM (Policy Map Configuration)
LC (Line Configuration)	VC (VLAN Database Configuration)
SG (Server Group)	

Line Commands

You can access the onboard configuration program by attaching a VT100 compatible device to the server's serial port. These commands are used to set communication parameters for the serial port or Telnet (i.e., a virtual terminal).

Table 4-5 Line Commands

Command	Function	Mode	Page
line	Identifies a specific line for configuration and starts the line configuration mode	GC	4-12
login	Enables password checking at login	LC	4-12
password	Specifies a password on a line	LC	4-13
timeout login response	Sets the interval that the system waits for a user to log into the CLI	LC	4-14
exec-timeout	Sets the interval that the command interpreter waits until user input is detected	LC	4-14
password-thresh	Sets the password intrusion threshold, which limits the number of failed logon attempts	LC	4-15
silent-time*	Sets the amount of time the management console is inaccessible after the number of unsuccessful logon attempts exceeds the threshold set by the password-thresh command	LC	4-16
databits*	Sets the number of data bits per character that are interpreted and generated by hardware	LC	4-16
parity*	Defines the generation of a parity bit	LC	4-17
speed*	Sets the terminal baud rate	LC	4-18
stopbits*	Sets the number of the stop bits transmitted per byte	LC	4-18
disconnect	Terminates a line connection	PE	4-19
show line	Displays a terminal line's parameters	NE, PE	4-19

* These commands only apply to the serial port.

line

This command identifies a specific line for configuration, and to process subsequent line configuration commands.

Syntax

line {console | vty}

- **console** - Console terminal line.
- **vty** - Virtual terminal for remote console access (i.e., Telnet).

Default Setting

There is no default line.

Command Mode

Global Configuration

Command Usage

Telnet is considered a virtual terminal connection and will be shown as “Vty” in screen displays such as **show users**. However, the serial communication parameters (e.g., databits) do not affect Telnet connections.

Example

To enter console line mode, enter the following command:

```
Console(config)#line console
Console(config-line)#
```

Related Commands

show line (4-19)
show users (4-81)

login

This command enables password checking at login. Use the **no** form to disable password checking and allow connections without a password.

Syntax

login [local]
no login

local - Selects local password checking. Authentication is based on the user name specified with the **username** command.

Default Setting

login local

Command Mode

Line Configuration

Command Usage

- There are three authentication modes provided by the switch itself at login:

- **login** selects authentication by a single global password as specified by the **password** line configuration command. When using this method, the management interface starts in Normal Exec (NE) mode.
 - **login local** selects authentication via the user name and password specified by the **username** command (i.e., default setting). When using this method, the management interface starts in Normal Exec (NE) or Privileged Exec (PE) mode, depending on the user's privilege level (0 or 15 respectively).
 - **no login** selects no authentication. When using this method, the management interface starts in Normal Exec (NE) mode.
- This command controls login authentication via the switch itself. To configure user names and passwords for remote authentication servers, you must use the RADIUS or TACACS software installed on those servers.

Example

```
Console(config-line)#login local
Console(config-line)#
```

Related Commands

username (4-37)
password (4-13)

password

This command specifies the password for a line. Use the **no** form to remove the password.

Syntax

password {**0** | **7**} *password*
no password

- {**0** | **7**} - 0 means plain password, 7 means encrypted password
- *password* - Character string that specifies the line password.
(Maximum length: 8 characters plain text, 32 encrypted, case sensitive)

Default Setting

No password is specified.

Command Mode

Line Configuration

Command Usage

- When a connection is started on a line with password protection, the system prompts for the password. If you enter the correct password, the system shows a prompt. You can use the **password-thresh** command to set the number of times a user can enter an incorrect password before the system terminates the line connection and returns the terminal to the idle state.
- The encrypted password is required for compatibility with legacy password settings (i.e., plain text or encrypted) when reading the configuration file

4 Command Line Interface

during system bootup or when downloading the configuration file from a TFTP server. There is no need for you to manually configure encrypted passwords.

Example

```
Console(config-line)#password 0 secret
Console(config-line)#
```

Related Commands

- login (4-12)
- password-thresh (4-15)

timeout login response

This command sets the interval that the system waits for a user to log into the CLI. Use the **no** form to restore the default.

Syntax

timeout login response [*seconds*]
no timeout login response

seconds - Integer that specifies the timeout interval.
(Range: 0 - 300 seconds; 0: disabled)

Default Setting

- CLI: Disabled (0 seconds)
- Telnet: 600 seconds

Command Mode

Line Configuration

Command Usage

- If a login attempt is not detected within the timeout interval, the connection is terminated for the session.
- This command applies to both the local console and Telnet connections.
- The timeout for Telnet cannot be disabled.
- Using the command without specifying a timeout restores the default setting.

Example

To set the timeout to two minutes, enter this command:

```
Console(config-line)#timeout login response 120
Console(config-line)#
```

Related Commands

- silent-time (4-16)
- exec-timeout (4-14)

exec-timeout

This command sets the interval that the system waits until user input is detected. Use the **no** form to restore the default.

Syntax

exec-timeout [*seconds*]
no exec-timeout

seconds - Integer that specifies the number of seconds.
(Range: 0-65535 seconds; 0: no timeout)

Default Setting

CLI: No timeout
Telnet: 10 minutes

Command Mode

Line Configuration

Command Usage

- If user input is detected within the timeout interval, the session is kept open; otherwise the session is terminated.
- This command applies to both the local console and Telnet connections.
- The timeout for Telnet cannot be disabled.
- Using the command without specifying a timeout restores the default setting.

Example

To set the timeout to two minutes, enter this command:

```
Console(config-line)#exec-timeout 120  
Console(config-line)#
```

Related Commands

silent-time (4-16)
timeout login response (4-13)

password-thresh

This command sets the password intrusion threshold which limits the number of failed logon attempts. Use the **no** form to remove the threshold value.

Syntax

password-thresh [*threshold*]
no password-thresh

threshold - The number of allowed password attempts.
(Range: 1-120; 0: no threshold)

Default Setting

The default value is three attempts.

Command Mode

Line Configuration

Command Usage

- When the logon attempt threshold is reached, the system interface becomes silent for a specified amount of time before allowing the next logon attempt. (Use the **silent-time** command to set this interval.) When this threshold is reached for Telnet, the Telnet logon interface shuts down.
- This command applies to both the local console and Telnet connections.

Example

To set the password threshold to five attempts, enter this command:

```
Console(config-line)#password-thresh 5
Console(config-line)#
```

Related Commands

- silent-time (4-16)
- timeout login response (4-13)

silent-time

This command sets the amount of time the management console is inaccessible after the number of unsuccessful logon attempts exceeds the threshold set by the **password-thresh** command. Use the **no** form to remove the silent time value.

Syntax

silent-time [*seconds*]
no silent-time

seconds - The number of seconds to disable console response.
(Range: 0-65535; 0: no silent-time)

Default Setting

The default value is no silent-time.

Command Mode

Line Configuration

Example

To set the silent time to 60 seconds, enter this command:

```
Console(config-line)#silent-time 60
Console(config-line)#
```

Related Commands

- password-thresh (4-15)

databits

This command sets the number of data bits per character that are interpreted and generated by the console port. Use the **no** form to restore the default value.

Syntax

databits {7 | 8}
no databits

- 7 - Seven data bits per character.
- 8 - Eight data bits per character.

Default Setting

8 data bits per character

Command Mode

Line Configuration

Command Usage

The **databits** command can be used to mask the high bit on input from devices that generate 7 data bits with parity. If parity is being generated, specify 7 data bits per character. If no parity is required, specify 8 data bits per character.

Example

To specify 7 data bits, enter this command:

```
Console(config-line)#databits 7
Console(config-line)#
```

Related Commands

parity (4-17)

parity

This command defines the generation of a parity bit. Use the **no** form to restore the default setting.

Syntax

parity {none | even | odd}
no parity

- **none** - No parity
- **even** - Even parity
- **odd** - Odd parity

Default Setting

No parity

Command Mode

Line Configuration

Command Usage

Communication protocols provided by devices such as terminals and modems often require a specific parity bit setting.

4 Command Line Interface

Example

To specify no parity, enter this command:

```
Console(config-line)#parity none
Console(config-line)#
```

speed

This command sets the terminal line's baud rate. This command sets both the transmit (to terminal) and receive (from terminal) speeds. Use the **no** form to restore the default setting.

Syntax

speed *bps*

no speed

bps - Baud rate in bits per second.
(Options: 9600, 19200, 38400 bps)

Default Setting

9600

Command Mode

Line Configuration

Command Usage

Set the speed to match the baud rate of the device connected to the serial port. Some baud rates available on devices connected to the port might not be supported. The system indicates if the speed you selected is not supported.

Example

To specify 38400 bps, enter this command:

```
Console(config-line)#speed 38400
Console(config-line)#
```

stopbits

This command sets the number of the stop bits transmitted per byte. Use the **no** form to restore the default setting.

Syntax

stopbits {1 | 2}

- 1 - One stop bit
- 2 - Two stop bits

Default Setting

1 stop bit

Command Mode

Line Configuration

Example

To specify 2 stop bits, enter this command:

```
Console(config-line)#stopbits 2
Console(config-line)#
```

disconnect

This command terminates an SSH, Telnet, or console connection.

Syntax

disconnect *session-id*

session-id – The session identifier for an SSH, Telnet or console connection. (Range: 0-4)

Command Mode

Privileged Exec

Command Usage

Specifying session identifier “0” will disconnect the console connection.

Specifying any other identifiers for an active session will disconnect an SSH or Telnet connection.

Example

```
Console#disconnect 1
Console#
```

Related Commands

show ssh (4-52)
show users (4-81)

show line

This command displays the terminal line's parameters.

Syntax

show line [**console** | **vty**]

- **console** - Console terminal line.
- **vty** - Virtual terminal for remote console access (i.e., Telnet).

Default Setting

Shows all lines

Command Mode

Normal Exec, Privileged Exec

4 Command Line Interface

Example

To show all lines, enter this command:

```
Console#show line
Console configuration:
  Password threshold: 3 times
  Interactive timeout: Disabled
  Login timeout: Disabled
  Silent time: Disabled
  Baudrate: 9600
  Databits: 8
  Parity: none
  Stopbits: 1

VTY configuration:
  Password threshold: 3 times
  Interactive timeout: 600 sec
  Login timeout: 300 sec
console#
```

General Commands

Table 4-6 General Commands

Command	Function	Mode	Page
enable	Activates privileged mode	NE	4-20
disable	Returns to normal mode from privileged mode	PE	4-21
configure	Activates global configuration mode	PE	4-22
show history	Shows the command history buffer	NE, PE	4-22
reload	Restarts the system	PE	4-23
reload cancel	Cancels a delayed reset of the system	PE	4-23
show reload	Displays the time remaining until a delayed reset will take place	PE	4-24
end	Returns to Privileged Exec mode	any config. mode	4-24
exit	Returns to the previous configuration mode, or exits the CLI	any	4-25
quit	Exits a CLI session	NE, PE	4-25
help	Shows how to use help	any	NA
?	Shows options for command completion (context sensitive)	any	NA

enable

This command activates Privileged Exec mode. In privileged mode, additional commands are available, and certain commands display additional information. See “Understanding Command Modes” on page 4-6.

Syntax

```
enable [level]
```

level - Privilege level to log into the device.

The device has two predefined privilege levels: 0: Normal Exec, 15: Privileged Exec. Enter level 15 to access Privileged Exec mode.

Default Setting

Level 15

Command Mode

Normal Exec

Command Usage

- “super” is the default password required to change the command mode from Normal Exec to Privileged Exec. (To set this password, see the **enable password** command on page 4-38.)
- The “#” character is appended to the end of the prompt to indicate that the system is in privileged access mode.

Example

```
Console>enable
Password: [privileged level password]
Console#
```

Related Commands

disable (4-21)

enable password (4-38)

disable

This command returns to Normal Exec mode from privileged mode. In normal access mode, you can only display basic information on the switch's configuration or Ethernet statistics. To gain access to all commands, you must use the privileged mode. See “Understanding Command Modes” on page 4-6.

Default Setting

None

Command Mode

Privileged Exec

Command Usage

The “>” character is appended to the end of the prompt to indicate that the system is in normal access mode.

Example

```
Console#disable
Console>
```

Related Commands

enable (4-20)

configure

This command activates Global Configuration mode. You must enter this mode to modify any settings on the switch. You must also enter Global Configuration mode prior to enabling some of the other configuration modes, including Interface Configuration, Line Configuration, and VLAN Database Configuration. See “Understanding Command Modes” on page 4-6.

Default Setting

None

Command Mode

Privileged Exec

Example

```
Console#configure
Console(config)#
```

Related Commands

end (4-24)

show history

This command shows the contents of the command history buffer.

Default Setting

None

Command Mode

Normal Exec, Privileged Exec

Command Usage

The history buffer size is fixed at 10 Execution commands and 10 Configuration commands.

Example

In this example, the show history command lists the contents of the command history buffer:

```
Console#show history
Execution command history:
 2 config
 1 show history

Configuration command history:
 4 interface vlan 1
 3 exit
 2 interface vlan 1
 1 end

Console#
```

The **!** command repeats commands from the Execution command history buffer when you are in Normal Exec or Privileged Exec Mode, and commands from the Configuration command history buffer when you are in any of the configuration modes. In this example, the **!2** command repeats the second command in the Execution history buffer (**config**).

```
Console#!2
Console#config
Console(config)#
```

reload

This command restarts the system. You can reboot the system immediately, or you can configure the switch to reset after a specified amount of time.

Syntax

reload [**in hour** *hours* | **minute** *minutes*]

hours - Specifies the amount of hours to wait, combined with the minutes, before the switch resets. (Range: 0-576; Default: 0)

minutes - Specifies the amount of minutes to wait, combined with the hours, before the switch resets. (Range: 1-34560; Default: 0)

Note: When the system is restarted, it will always run the Power-On Self-Test. It will also retain all configuration information stored in non-volatile memory by the **copy running-config startup-config** command (See “copy” on page 4-84).

Default Setting

None

Command Mode

Privileged Exec

Command Usage

This command resets the entire system. The switch will wait the designated amount of time before resetting. If a delayed reset was already scheduled, then the newly configured reset will overwrite the original delay configuration. The configured delay time cannot exceed 24 days (576 hours, or 34560 minutes). If no time is specified, then the switch will reboot immediately.

Example

This example shows how to reset the switch:

```
Console#reload
System will be restarted, continue <y/n>? y
```

reload cancel

This command cancels a pending delayed reset.

Syntax

reload cancel

4 Command Line Interface

Default Setting

None

Command Mode

Privileged Exec

Example

This example shows how to cancel a configured delayed reset of the switch:

```
Console#reload cancel
Console#
```

show reload

This command displays the remaining time until a pending delayed reset will take place.

Syntax

show reload

Default Setting

None

Command Mode

Privileged Exec

Example

This example shows how to display the remaining time until a configured delayed reset of the switch will take place:

```
Console#show reload

The switch will be rebooted at Nov 23 22:52:14 2007.
Remaining Time : 0 days, 4 hours, 31 minutes, 46 seconds.

Console#
```

end

This command returns to Privileged Exec mode.

Default Setting

None

Command Mode

Global Configuration, Interface Configuration, Line Configuration, and VLAN Database Configuration.

Example

This example shows how to return to the Privileged Exec mode from the Interface Configuration mode:

```
Console(config-if)#end
Console#
```

exit

This command returns to the previous configuration mode or exit the configuration program.

Default Setting

None

Command Mode

Any

Example

This example shows how to return to the Privileged Exec mode from the Global Configuration mode, and then quit the CLI session:

```
Console(config)#exit
Console#exit

Press ENTER to start session
User Access Verification

Username:
```

quit

This command exits the configuration program.

Default Setting

None

Command Mode

Normal Exec, Privileged Exec

Command Usage

The **quit** and **exit** commands can both exit the configuration program.

Example

This example shows how to quit a CLI session:

```
Console#quit

Press ENTER to start session

User Access Verification

Username:
```

System Management Commands

These commands are used to control system logs, passwords, user names, browser configuration options, and display or configure a variety of other system information.

Table 4-7 System Management Commands

Command Group	Function	Page
Device Designation	Configures information that uniquely identifies this switch	4-26
Banner	Configures administrative contact and device identification and location information	4-27
User Access	Configures the basic user names and passwords for management access	4-37
IP Filter	Configures IP addresses that are allowed management access	4-39
Web Server	Enables management access via a web browser	4-41
Telnet Server	Enables management access via Telnet	4-44
Secure Shell	Provides secure replacement for Telnet	4-45
Event Logging	Controls logging of error messages	4-54
Time (System Clock)	Sets the system clock automatically via NTP/SNTP server or manually	4-64
System Status	Displays system configuration, active managers, and version information	4-77
Frame Size	Enables support for jumbo frames	4-83

Device Designation Commands

Table 4-8 Device Designation Commands

Command	Function	Mode	Page
prompt	Customizes the prompt used in PE and NE mode	GC	4-26
hostname	Specifies the host name for the switch	GC	4-27
snmp-server contact	Sets the system contact string	GC	4-152
snmp-server location	Sets the system location string	GC	4-152

prompt

This command customizes the CLI prompt. Use the **no** form to restore the default prompt.

Syntax

prompt *string*

no prompt

string - Any alphanumeric string to use for the CLI prompt. (Maximum length: 255 characters)

Default Setting

Console

Command Mode

Global Configuration

Example

```
Console(config)#prompt RD2
RD2(config)#
```

hostname

This command specifies or modifies the host name for this device. Use the **no** form to restore the default host name.

Syntax**hostname** *name***no hostname**

name - The name of this host. (Maximum length: 255 characters)

Default Setting

None

Command Mode

Global Configuration

Example

```
Console(config)#hostname RD#1
Console(config)#
```

Banner

These commands are used to configure and manage administrative information about the switch, its exact data center location, details of the electrical and network circuits that supply the switch, as well as network administrator and manager contact information. This information is only available via the CLI and is automatically displayed before login as soon as a console or telnet connection has been established.

Table 4-9 Banner Commands

Command	Function	Mode	Page
banner configure	Configures the banner information that is displayed before login	GC	4-28
banner configure company	Configures the Company information that is displayed by banner	GC	4-29
banner configure dc-power-info	Configures the DC Power information that is displayed by banner	GC	4-30
banner configure department	Configures the Department information that is displayed by banner	GC	4-30
banner configure equipment-info	Configures the Equipment information that is displayed by banner	GC	4-31

Table 4-9 Banner Commands

Command	Function	Mode	Page
banner configure equipment-location	Configures the Equipment Location information that is displayed by banner	GC	4-32
banner configure ip-lan	Configures the IP and LAN information that is displayed by banner	GC	4-32
banner configure lp-number	Configures the LP Number information that is displayed by banner	GC	4-33
banner configure manager-info	Configures the Manager contact information that is displayed by banner	GC	4-34
banner configure mux	Configures the MUX information that is displayed by banner	GC	4-34
banner configure note	Configures miscellaneous information that is displayed by banner under the Notes heading	GC	4-35
show banner	Displays all banner information	NE, PE	4-36

banner configure

This command allows the administrator to interactively specify administrative information for this device.

Syntax

banner configure

Default Setting

None

Command Mode

Global Configuration

Command Usage

The administrator can batch-input all details for the switch with one command. When the administrator finishes typing the company name and presses the enter key, the script prompts for the next piece of information, and so on, until all information has been entered. Pressing enter without inputting information at any prompt during the script's operation will leave the field empty. Spaces can be used during script mode because pressing the enter key signifies the end of data input. The delete and left-arrow keys terminate the script. The use of the backspace key during script mode is not supported. If, for example, a mistake is made in the company name, it can be corrected with the **banner configure company** command.

Example

```
Console(config)#banner configure
Company: TPL
Responsible department: R&D Dept
Name and telephone to Contact the management people
Manager1 name: Sr. Network Admin
  phone number: 123-555-1212
Manager2 name: Jr. Network Admin
  phone number: 123-555-1213
Manager3 name: Night-shift Net Admin / Janitor
  phone number: 123-555-1214
The physical location of the equipment.
City and street address: 12 Straight St. Motown, Zimbabwe
Information about this equipment:
Manufacturer: TPL Networks
ID: 123_unique_id_number
Floor: 2
Row: 7
Rack: 29
Shelf in this rack: 8
Information about DC power supply.
Floor: 2
Row: 7
Rack: 25
Electrical circuit: : ec-177743209-xb
Number of LP:12
Position of the equipment in the MUX:1/23
IP LAN:192.168.1.1
Note: This is a random note about this managed switch and can contain
miscellaneous information.
Console(config)#
```

banner configure company

This command allows the administrator to configure the company information displayed in the banner. Use the **no** form to remove the company name information from the banner display.

Syntax

banner configure company *name*

no banner configure company

name - The name of the company. (Maximum length: 32 characters)

Default Setting

None

Command Mode

Global Configuration

Command Usage

The user-entered data cannot contain spaces. The **banner configure company** command interprets spaces as data input boundaries. The use of underscores (`_`) or other unobtrusive non-letter characters is suggested for situations where whitespace is necessary for clarity.

Example

```
Console(config)#banner configure company TPL
Console(config)#
```

banner configure dc-power-info

This command allows the administrator to configure the DC power information displayed in the banner. Use the **no** form to remove the DC power information from the banner display.

Syntax

```
banner configure dc-power-info floor floor-id row row-id rack rack-id
electrical-circuit ec-id
no banner configure dc-power-info [floor | row | rack | electrical-circuit]
```

floor-id - The floor number. (Maximum length: 32 characters)

row-id - The row number. (Maximum length: 32 characters)

rack-id - The rack number. (Maximum length: 32 characters)

ec-id - The electrical circuit ID. (Maximum length: 32 characters)

Default Setting

None

Command Mode

Global Configuration

Command Usage

The user-entered data cannot contain spaces. The **banner configure dc-power-info** command interprets spaces as data input boundaries. The use of underscores (`_`) or other unobtrusive non-letter characters is suggested for situations where whitespace is necessary for clarity.

Example

```
Console(config)#banner configure floor 3 row 15 rack 24
  electrical-circuit 48v-id_3.15.24.2
Console(config)#
```

banner configure department

This command allows the administrator to configure the department information displayed in the banner. Use the **no** form to remove the department information from the banner display.

Syntax

banner configure department *dept-name*
no banner configure company

dept-name - The name of the department. (Maximum length: 32 characters)

Default Setting

None

Command Mode

Global Configuration

Command Usage

The user-entered data cannot contain spaces. The **banner configure department** command interprets spaces as data input boundaries. The use of underscores (`_`) or other unobtrusive non-letter characters is suggested for situations where whitespace is necessary for clarity.

Example

```
Console(config)#banner configure department R&D
Console(config)#
```

banner configure equipment-info

This command allows the administrator to configure the equipment information displayed in the banner. Use the **no** form to remove the equipment information from the banner display.

Syntax

banner configure equipment-info manufacturer-id *mfr-id* **floor** *floor-id* **row** *row-id* **rack** *rack-id* **shelf-rack** *sr-id* **manufacturer** *mfr-name*
no banner configure equipment-info [**floor** | **manufacturer** | **manufacturer-id** | **rack** | **row** | **shelf-rack**]

mfr-id - The name of the device model number. (Maximum length: 32 characters)

floor-id - The floor number. (Maximum length: 32 characters)

row-id - The row number. (Maximum length: 32 characters)

rack-id - The rack number. (Maximum length: 32 characters)

sr-id - The shelf number in the rack. (Maximum length: 32 characters)

mfr-name - The name of the device manufacturer. (Maximum length: 32 characters)

Default Setting

None

Command Mode

Global Configuration

Command Usage

The user-entered data cannot contain spaces. The **banner configure equipment-info** command interprets spaces as data input boundaries. The use of underscores (`_`) or other unobtrusive non-letter characters is suggested for situations where whitespace is necessary for clarity.

Example

```
Console(config)#banner configure equipment-info manufacturer-id TL-SL5428
  floor 3 row 10 rack 15 shelf-rack 12 manufacturer TPL_Networks
Console(config)#
```

banner configure equipment-location

This command allows the administrator to configure the equipment location information displayed in the banner. Use the **no** form to remove the equipment location information from the banner display.

Syntax

banner configure equipment-location *location*
no banner configure equipment-location

location - The address location of the device. (Maximum length: 32 characters)

Default Setting

None

Command Mode

Global Configuration

Command Usage

The user-entered data cannot contain spaces. The **banner configure equipment-location** command interprets spaces as data input boundaries. The use of underscores (`_`) or other unobtrusive non-letter characters is suggested for situations where whitespace is necessary for clarity.

Example

```
Console(config)#banner configure equipment-location
  710_Network_Path,_Indianapolis
Console(config)#
```

banner configure ip-lan

This command allows the administrator to configure the device IP address and subnet mask information displayed in the banner. Use the **no** form to remove the IP and subnet information from the banner display.

Syntax

banner configure ip-lan *ip-mask*
no banner configure ip-lan

ip-mask - The IP address and subnet mask of the device. (Maximum length: 32 characters)

Default Setting

None

Command Mode

Global Configuration

Command Usage

The user-entered data cannot contain spaces. The **banner configure ip-lan** command interprets spaces as data input boundaries. The use of underscores (`_`) or other unobtrusive non-letter characters is suggested for situations where whitespace is necessary for clarity.

Example

```
Console(config)#banner configure ip-lan 192.168.1.1/255.255.255.0
Console(config)#
```

banner configure lp-number

This command allows the administrator to configure the LP number information displayed in the banner. Use the **no** form to remove the LP number information from the banner display.

Syntax

banner configure lp-number *lp-num*
no banner configure lp-number

lp-num - The LP number. (Maximum length: 32 characters)

Default Setting

None

Command Mode

Global Configuration

Command Usage

The user-entered data cannot contain spaces. The **banner configure lp-number** command interprets spaces as data input boundaries. The use of underscores (`_`) or other unobtrusive non-letter characters is suggested for situations where whitespace is necessary for clarity.

Example

```
Console(config)#banner configure lp-number 12
Console(config)#
```

banner configure manager-info

This command allows the administrator to configure the manager contact information displayed in the banner. Use the **no** form to remove the manager contact information from the banner display.

Syntax

```
banner configure manager-info name mgr1-name phone-number mgr1-number [name2 mgr2-name phone-number mgr2-number | name3 mgr3-name phone-number mgr3-number]  
no banner configure manager-info [name1 | name2 | name3]
```

mgr1-name - The name of the first manager. (Maximum length: 32 characters)

mgr1-number - The phone number of the first manager. (Maximum length: 32 characters)

mgr2-name - The name of the second manager. (Maximum length: 32 characters)

mgr2-number - The phone number of the second manager. (Maximum length: 32 characters)

mgr3-name - The name of the third manager. (Maximum length: 32 characters)

mgr3-number - The phone number of the third manager. (Maximum length: 32 characters)

Default Setting

None

Command Mode

Global Configuration

Command Usage

The user-entered data cannot contain spaces. The **banner configure manager-info** command interprets spaces as data input boundaries. The use of underscores (`_`) or other unobtrusive non-letter characters is suggested for situations where whitespace is necessary for clarity.

Example

```
Console(config)#banner configure manager-info name Albert_Einstein  
phone-number 123-555-1212 name2 Lamar phone-number 123-555-1219  
Console(config)#
```

banner configure mux

This command allows the administrator to configure the mux information displayed in the banner. Use the **no** form to remove the mux information from the banner display.

Syntax

```
banner configure mux muxinfo
```

no banner configure mux

muxinfo - The circuit and PVC to which the switch is connected.
(Maximum length: 32 characters)

Default Setting

None

Command Mode

Global Configuration

Command Usage

The user-entered data cannot contain spaces. The **banner configure mux** command interprets spaces as data input boundaries. The use of underscores (`_`) or other unobtrusive non-letter characters is suggested for situations where whitespace is necessary for clarity.

Example

```
Console(config)#banner configure mux telco-8734212kx_PVC-1/23
Console(config)#
```

banner configure note

This command allows the administrator to configure the note information displayed in the banner. Use the **no** form to remove the note information from the banner display.

Syntax

banner configure note *note-info*
no banner configure note

note-info - Miscellaneous information that does not fit the other banner categories, or any other information of importance to users of the switch CLI. (Maximum length: 150 characters)

Default Setting

None

Command Mode

Global Configuration

Command Usage

The user-entered data cannot contain spaces. The **banner configure note** command interprets spaces as data input boundaries. The use of underscores (`_`) or other unobtrusive non-letter characters is suggested for situations where whitespace is necessary for clarity.

Example

```
Console(config)#banner configure note !!!!!ROUTINE_MAINTENANCE_firmware-
upgrade_0100-0500_GMT-0500_20071022!!!!!!_20min_network_impact_expected
Console(config)#
```

show banner

This command displays all banner information.

Syntax

show banner

Default Setting

None

Command Mode

Normal Exec, Privileged Exec

Example

```
Console#show banner
TPL
WARNING - MONITORED ACTIONS AND ACCESSES
R&D_Dept

Albert_Einstein - 123-555-1212
Steve - 123-555-9876
Lamar - 123-555-3322

Station's information:
710_Network_Path,Indianapolis

TL-SL5428
Floor / Row / Rack / Sub-Rack
7 / 10 / 15 / 6
DC power supply:
Power Source A: Floor / Row / Rack / Electrical circuit
3 / 15 / 24 / 48V-id_3.15.24.2

Number of LP: 4
Position MUX: telco-9734212kx_PVC-1/23
IP LAN: 216.241.132.3/255.255.255.0
Note:
!!!!!!ROUTINE_MAINTENANCE_firmware-upgrade_0100--0500_GMT-0500_20071022!!!!
!!_20min_network_impact_expected
Console#
```

User Access Commands

The basic commands required for management access are listed in this section. This switch also includes other options for password checking via the console or a Telnet connection (page 4-11), user authentication via a remote authentication server (page 4-90), and host access authentication for specific ports (page 4-111).

Table 4-10 User Access Commands

Command	Function	Mode	Page
username	Establishes a user name-based authentication system at login	GC	4-37
enable password	Sets a password to control access to the Privileged Exec level	GC	4-38

username

This command adds named users, requires authentication at login, specifies or changes a user's password (or specify that no password is required), or specifies or changes a user's access level. Use the **no** form to remove a user name.

Syntax

```
username name {access-level level | nopassword |
password {0 | 7} password}
no username name
```

- **name** - The name of the user.
(Maximum length: 8 characters, case sensitive. Maximum users: 16)
- **access-level level** - Specifies the user level.
The device has two predefined privilege levels:
0: Normal Exec, **15**: Privileged Exec.
- **nopassword** - No password is required for this user to log in.
- **{0 | 7}** - 0 means plain password, 7 means encrypted password.
- **password password** - The authentication password for the user.
(Maximum length: 8 characters plain text, 32 encrypted, case sensitive)

Default Setting

- The default access level is Normal Exec.
- The factory defaults for the user names and passwords are:

Table 4-11 Default Login Settings

username	access-level	password
guest	0	guest
admin	15	admin

Command Mode

Global Configuration

Command Usage

The encrypted password is required for compatibility with legacy password settings (i.e., plain text or encrypted) when reading the configuration file during system bootup or when downloading the configuration file from a TFTP server. There is no need for you to manually configure encrypted passwords.

Example

This example shows how to set the access level and password for a user.

```
Console(config)#username bob access-level 15
Console(config)#username bob password 0 smith
Console(config)#
```

enable password

After initially logging onto the system, you should set the Privileged Exec password. Remember to record it in a safe place. This command controls access to the Privileged Exec level from the Normal Exec level. Use the **no** form to reset the default password.

Syntax

enable password [level *level*] {0 | 7} *password*
no enable password [level *level*]

- **level** *level* - Level 15 for Privileged Exec. (Levels 0-14 are not used.)
- {0 | 7} - 0 means plain password, 7 means encrypted password.
- *password* - password for this privilege level.

(Maximum length: 8 characters plain text, 32 encrypted, case sensitive)

Default Setting

- The default is level 15.
- The default password is "super"

Command Mode

Global Configuration

Command Usage

- You cannot set a null password. You will have to enter a password to change the command mode from Normal Exec to Privileged Exec with the **enable** command (page 4-20).
- The encrypted password is required for compatibility with legacy password settings (i.e., plain text or encrypted) when reading the configuration file during system bootup or when downloading the configuration file from a TFTP server. There is no need for you to manually configure encrypted passwords.

Example

```
Console(config)#enable password level 15 0 admin
Console(config)#
```

Related Commands

enable (4-20)

authentication enable (4-92)

IP Filter Commands

Table 4-12 IP Filter Commands

Command	Function	Mode	Page
management	Configures IP addresses that are allowed management access	GC	4-39
show management	Displays the switch to be monitored or configured from a browser	PE	4-40

management

This command specifies the client IP addresses that are allowed management access to the switch through various protocols. Use the **no** form to restore the default setting.

Syntax

[no] management {all-client | http-client | snmp-client | telnet-client}
start-address [end-address]

- **all-client** - Adds IP address(es) to the SNMP, web and Telnet groups.
- **http-client** - Adds IP address(es) to the web group.
- **snmp-client** - Adds IP address(es) to the SNMP group.
- **telnet-client** - Adds IP address(es) to the Telnet group.
- *start-address* - A single IP address, or the starting address of a range.
- *end-address* - The end address of a range.

Default Setting

All addresses

Command Mode

Global Configuration

Command Usage

- If anyone tries to access a management interface on the switch from an invalid address, the switch will reject the connection, enter an event message in the system log, and send a trap message to the trap manager.
- IP address can be configured for SNMP, web and Telnet access respectively. Each of these groups can include up to five different sets of addresses, either individual addresses or address ranges.
- When entering addresses for the same group (i.e., SNMP, web or Telnet), the switch will not accept overlapping address ranges. When entering addresses for different groups, the switch will accept overlapping address ranges.
- You cannot delete an individual address from a specified range. You must delete the entire range, and reenter the addresses.

4 Command Line Interface

- You can delete an address range just by specifying the start address, or by specifying both the start address and end address.

Example

This example restricts management access to the indicated addresses.

```
Console(config)#management all-client 192.168.1.19
Console(config)#management all-client 192.168.1.25 192.168.1.30
Console(config)#
```

show management

This command displays the client IP addresses that are allowed management access to the switch through various protocols.

Syntax

show management {all-client | http-client | snmp-client | telnet-client}

- **all-client** - Adds IP address(es) to the SNMP, web and Telnet groups.
- **http-client** - Adds IP address(es) to the web group.
- **snmp-client** - Adds IP address(es) to the SNMP group.
- **telnet-client** - Adds IP address(es) to the Telnet group.

Command Mode

Privileged Exec

Example

```
Console#show management all-client
Management IP Filter
HTTP-Client:
  Start IP address      End IP address
-----
1. 192.168.1.19        192.168.1.19
2. 192.168.1.25        192.168.1.30

SNMP-Client:
  Start IP address      End IP address
-----
1. 192.168.1.19        192.168.1.19
2. 192.168.1.25        192.168.1.30

TELNET-Client:
  Start IP address      End IP address
-----
1. 192.168.1.19        192.168.1.19
2. 192.168.1.25        192.168.1.30

Console#
```

Web Server Commands

Table 4-13 Web Server Commands

Command	Function	Mode	Page
ip http port	Specifies the port to be used by the web browser interface	GC	4-41
ip http server	Allows the switch to be monitored or configured from a browser	GC	4-41
ip http secure-server	Enables HTTPS for encrypted communications	GC	4-42
ip http secure-port	Specifies the UDP port number for HTTPS	GC	4-43

ip http port

This command specifies the TCP port number used by the web browser interface. Use the **no** form to use the default port.

Syntax

```
ip http port port-number
no ip http port
```

port-number - The TCP port to be used by the browser interface.
(Range: 1-65535)

Default Setting

80

Command Mode

Global Configuration

Example

```
Console(config)#ip http port 769
Console(config)#
```

Related Commands

ip http server (4-41)

ip http server

This command allows this device to be monitored or configured from a browser. Use the **no** form to disable this function.

Syntax

```
[no] ip http server
```

Default Setting

Enabled

Command Mode

Global Configuration

Example

```
Console(config)#ip http server
Console(config)#
```

Related Commands

ip http port (4-41)

ip http secure-server

This command enables the secure hypertext transfer protocol (HTTPS) over the Secure Socket Layer (SSL), providing secure access (i.e., an encrypted connection) to the switch's web interface. Use the **no** form to disable this function.

Syntax

[no] ip http secure-server

Default Setting

Enabled

Command Mode

Global Configuration

Command Usage

- Both HTTP and HTTPS service can be enabled independently on the switch. However, you cannot configure the HTTP and HTTPS servers to use the same UDP port.
- If you enable HTTPS, you must indicate this in the URL that you specify in your browser: **https://device[:port_number]**
- When you start HTTPS, the connection is established in this way:
 - The client authenticates the server using the server's digital certificate.
 - The client and server negotiate a set of security protocols to use for the connection.
 - The client and server generate session keys for encrypting and decrypting data.
- The client and server establish a secure encrypted connection. A padlock icon should appear in the status bar for Internet Explorer 5.x and Netscape Navigator 6.2 or later versions.
- The following web browsers and operating systems currently support HTTPS:

Table 4-14 HTTPS System Support

Web Browser	Operating System
Internet Explorer 5.0 or later	Windows 98, Windows NT (with service pack 6a), Windows 2000, Windows XP
Netscape Navigator 6.2 or later	Windows 98, Windows NT (with service pack 6a), Windows 2000, Windows XP, Solaris 2.6

- To specify a secure-site certificate, see "Replacing the Default Secure-site Certificate" on page 3-70. Also refer to the **copy** command on page 4-84.

Example

```
Console(config)#ip http secure-server
Console(config)#
```

Related Commands

ip http secure-port (4-43)
copy tftp https-certificate (4-84)

ip http secure-port

This command specifies the UDP port number used for HTTPS connection to the switch's web interface. Use the **no** form to restore the default port.

Syntax

ip http secure-port *port_number*
no ip http secure-port

port_number – The UDP port used for HTTPS.
(Range: 1-65535)

Default Setting

443

Command Mode

Global Configuration

Command Usage

- You cannot configure the HTTP and HTTPS servers to use the same port.
- If you change the HTTPS port number, clients attempting to connect to the HTTPS server must specify the port number in the URL, in this format:

https://device:port_number

Example

```
Console(config)#ip http secure-port 1000
Console(config)#
```

Related Commands

ip http secure-server (4-42)

Telnet Server Commands

Table 4-15 Telnet Server Commands

Command	Function	Mode	Page
ip telnet port	Specifies the port to be used by the Telnet interface	GC	4-41
ip telnet server	Allows the switch to be monitored or configured from Telnet	GC	4-41

ip telnet port

This command specifies the TCP port number used by the Telnet interface. Use the **no** form to use the default port.

Syntax

ip telnet port *port-number*
no ip telnet port

port-number - The TCP port to be used by the browser interface.
(Range: 1-65535)

Default Setting

23

Command Mode

Global Configuration

Example

```
Console(config)#ip telnet port 123  
Console(config)#
```

Related Commands

ip telnet server (4-44)

ip telnet server

This command allows this device to be monitored or configured from Telnet. Use the **no** form to disable this function.

Syntax

[no] ip telnet server

Default Setting

Enabled

Command Mode

Global Configuration

Example

```
Console(config)#ip telnet server  
Console(config)#
```

Related Commands

ip telnet port (4-44)

Secure Shell Commands

The Berkley-standard includes remote access tools originally designed for Unix systems. Some of these tools have also been implemented for Microsoft Windows and other environments. These tools, including commands such as *rlogin* (remote login), *rsh* (remote shell), and *rcp* (remote copy), are not secure from hostile attacks.

The Secure Shell (SSH) includes server/client applications intended as a secure replacement for the older Berkley remote access tools. SSH can also provide remote management access to this switch as a secure replacement for Telnet. When a client contacts the switch via the SSH protocol, the switch uses a public-key that the client must match along with a local user name and password for access authentication. SSH also encrypts all data transfers passing between the switch and SSH-enabled management station clients, and ensures that data traveling over the network arrives unaltered.

This section describes the commands used to configure the SSH server. However, note that you also need to install a SSH client on the management station when using this protocol to configure the switch.

Note: The switch supports both SSH Version 1.5 and 2.0.

Table 4-16 SSH Commands

Command	Function	Mode	Page
ip ssh server	Enables the SSH server on the switch	GC	4-47
ip ssh timeout	Specifies the authentication timeout for the SSH server	GC	4-48
ip ssh authentication-retries	Specifies the number of retries allowed by a client	GC	4-48
ip ssh server-key size	Sets the SSH server key size	GC	4-49
copy tftp public-key	Copies the user's public key from a TFTP server to the switch	PE	4-84
delete public-key	Deletes the public key for the specified user	PE	4-49
ip ssh crypto host-key generate	Generates the host key	PE	4-50
ip ssh crypto zeroize	Clear the host key from RAM	PE	4-50
ip ssh save host-key	Saves the host key from RAM to flash memory	PE	4-51
disconnect	Terminates a line connection	PE	4-19
show ip ssh	Displays the status of the SSH server and the configured values for authentication timeout and retries	PE	4-51
show ssh	Displays the status of current SSH sessions	PE	4-52
show public-key	Shows the public key for the specified user or for the host	PE	4-53
show users	Shows SSH users, including privilege level and public key type	PE	4-81

The SSH server on this switch supports both password and public key authentication. If password authentication is specified by the SSH client, then the password can be authenticated either locally or via a RADIUS or TACACS+ remote authentication server, as specified by the **authentication login** command on page 4-91. If public key authentication is specified by the client, then you must configure authentication keys on both the client and the switch as described in the following section. Note that regardless of whether you use public key or password authentication, you still have to generate authentication keys on the switch and enable the SSH server.

To use the SSH server, complete these steps:

1. Generate a Host Key Pair – Use the **ip ssh crypto host-key generate** command to create a host public/private key pair.
2. Provide Host Public Key to Clients – Many SSH client programs automatically import the host public key during the initial connection setup with the switch. Otherwise, you need to manually create a known hosts file on the management station and place the host public key in it. An entry for a public key in the known hosts file would appear similar to the following example:

```
10.1.0.54 1024 35 15684995401867669259333946775054617325313674890836547254
15020245593199868544358361651999923329781766065830956 10825913212890233
76546801726272571413428762941301196195566782 59566410486957427888146206
51941746772984865468615717739390164779355942303577413098022737087794545
24083971752646358058176716709574804776117
```

3. Import Client's Public Key to the Switch – Use the **copy tftp public-key** command to copy a file containing the public key for all the SSH client's granted management access to the switch. (Note that these clients must be configured locally on the switch via the User Accounts page as described on page 3-51.) The clients are subsequently authenticated using these keys. The current firmware only accepts public key files based on standard UNIX format as shown in the following example for an RSA Version 1 key:

```
1024 35 1341081685609893921040944920155425347631641921872958921143173880
05553616163105177594083868631109291232226828519254374603100937187721199
69631781366277414168985132049117204830339254324101637997592371449011938
00609025394840848271781943722884025331159521348610229029789827213532671
31629432532818915045306393916643 steve@192.168.1.19
```

4. Set the Optional Parameters – Set other optional parameters, including the authentication timeout, the number of retries, and the server key size.
5. Enable SSH Service – Use the **ip ssh server** command to enable the SSH server on the switch.
6. Configure Challenge-Response Authentication – When an SSH client attempts to contact the switch, the SSH server uses the host key pair to negotiate a session key and encryption method. Only clients that have a private key

corresponding to the public keys stored on the switch can gain access. The following exchanges take place during this process:

- a. The client sends its public key to the switch.
- b. The switch compares the client's public key to those stored in memory.
- c. If a match is found, the switch uses the public key to encrypt a random sequence of bytes, and sends this string to the client.
- d. The client uses its private key to decrypt the bytes, and sends the decrypted bytes back to the switch.
- e. The switch compares the decrypted bytes to the original bytes it sent. If the two sets match, this means that the client's private key corresponds to an authorized public key, and the client is authenticated.

Note: To use SSH with only password authentication, the host public key must still be given to the client, either during initial connection or manually entered into the known host file. However, you do not need to configure the client's keys.

ip ssh server

This command enables the Secure Shell (SSH) server on this switch. Use the **no** form to disable this service.

Syntax

[no] ip ssh server

Default Setting

Disabled

Command Mode

Global Configuration

Command Usage

- The SSH server supports up to four client sessions. The maximum number of client sessions includes both current Telnet sessions and SSH sessions.
- The SSH server uses DSA or RSA for key exchange when the client first establishes a connection with the switch, and then negotiates with the client to select either DES (56-bit) or 3DES (168-bit) for data encryption.
- You must generate the host key before enabling the SSH server.

Example

```
Console#ip ssh crypto host-key generate dsa
Console#configure
Console(config)#ip ssh server
Console(config)#
```

Related Commands

ip ssh crypto host-key generate (4-50)
show ssh (4-52)

ip ssh timeout

This command configures the timeout for the SSH server. Use the **no** form to restore the default setting.

Syntax

```
ip ssh timeout seconds  
no ip ssh timeout
```

seconds – The timeout for client response during SSH negotiation.
(Range: 1-120)

Default Setting

10 seconds

Command Mode

Global Configuration

Command Usage

The **timeout** specifies the interval the switch will wait for a response from the client during the SSH negotiation phase. Once an SSH session has been established, the timeout for user input is controlled by the **exec-timeout** command for vty sessions.

Example

```
Console(config)#ip ssh timeout 60  
Console(config)#
```

Related Commands

exec-timeout (4-14)
show ip ssh (4-51)

ip ssh authentication-retries

This command configures the number of times the SSH server attempts to reauthenticate a user. Use the **no** form to restore the default setting.

Syntax

```
ip ssh authentication-retries count  
no ip ssh authentication-retries
```

count – The number of authentication attempts permitted after which the interface is reset. (Range: 1-5)

Default Setting

3

Command Mode

Global Configuration

Example

```
Console(config)#ip ssh authentication-retires 2
Console(config)#
```

Related Commands

show ip ssh (4-51)

ip ssh server-key size

This command sets the SSH server key size. Use the **no** form to restore the default setting.

Syntax

ip ssh server-key size *key-size*
no ip ssh server-key size

key-size – The size of server key. (Range: 512-896 bits)

Default Setting

768 bits

Command Mode

Global Configuration

Command Usage

- The server key is a private key that is never shared outside the switch.
- The host key is shared with the SSH client, and is fixed at 1024 bits.

Example

```
Console(config)#ip ssh server-key size 512
Console(config)#
```

delete public-key

This command deletes the specified user's public key.

Syntax

delete public-key *username* [**dsa** | **rsa**]

- *username* – Name of an SSH user. (Range: 1-8 characters)
- **dsa** – DSA public key type.
- **rsa** – RSA public key type.

Default Setting

Deletes both the DSA and RSA key.

Command Mode

Privileged Exec

Example

```
Console#delete public-key admin dsa
Console#
```

ip ssh crypto host-key generate

This command generates the host key pair (i.e., public and private).

Syntax

ip ssh crypto host-key generate [dsa | rsa]

- **dsa** – DSA (Version 2) key type.
- **rsa** – RSA (Version 1) key type.

Default Setting

Generates both the DSA and RSA key pairs.

Command Mode

Privileged Exec

Command Usage

- This command stores the host key pair in memory (i.e., RAM). Use the **ip ssh save host-key** command to save the host key pair to flash memory.
- Some SSH client programs automatically add the public key to the known hosts file as part of the configuration process. Otherwise, you must manually create a known hosts file and place the host public key in it.
- The SSH server uses this host key to negotiate a session key and encryption method with the client trying to connect to it.

Example

```
Console#ip ssh crypto host-key generate dsa
Console#
```

Related Commands

ip ssh crypto zeroize (4-50)
ip ssh save host-key (4-51)

ip ssh crypto zeroize

This command clears the host key from memory (i.e. RAM).

Syntax

ip ssh crypto zeroize [dsa | rsa]

- **dsa** – DSA key type.
- **rsa** – RSA key type.

Default Setting

Clears both the DSA and RSA key.

Command Mode

Privileged Exec

Command Usage

- This command clears the host key from volatile memory (RAM). Use the **no ip ssh save host-key** command to clear the host key from flash memory.
- The SSH server must be disabled before you can execute this command.

Example

```
Console#ip ssh crypto zeroize dsa
Console#
```

Related Commands

- ip ssh crypto host-key generate (4-50)
- ip ssh save host-key (4-51)
- no ip ssh server (4-47)

ip ssh save host-key

This command saves host key from RAM to flash memory.

Syntax

ip ssh save host-key [dsa | rsa]

- **dsa** – DSA key type.
- **rsa** – RSA key type.

Default Setting

Saves both the DSA and RSA key.

Command Mode

Privileged Exec

Example

```
Console#ip ssh save host-key dsa
Console#
```

Related Commands

- ip ssh crypto host-key generate (4-50)

show ip ssh

This command displays the connection settings used when authenticating client access to the SSH server.

Command Mode

Privileged Exec

Example

```

Console#show ip ssh
SSH Enabled - version 1.99
Negotiation timeout: 120 secs; Authentication retries: 3
Server key size: 768 bits
Console#
    
```

show ssh

This command displays the current SSH server connections.

Command Mode

Privileged Exec

Example

```

Console#show ssh
Connection Version State Username Encryption
0 2.0 Session-Started admin ctos aes128-cbc-hmac-md5
stoc aes128-cbc-hmac-md5
Console#
    
```

Table 4-17 show ssh - display description

Field	Description
Session	The session number. (Range: 0-3)
Version	The Secure Shell version number.
State	The authentication negotiation state. (Values: Negotiation-Started, Authentication-Started, Session-Started)
Username	The user name of the client.
Encryption	<p>The encryption method is automatically negotiated between the client and server. Options for SSHv1.5 include: DES, 3DES Options for SSHv2.0 can include different algorithms for the client-to-server (ctos) and server-to-client (stoc):</p> <pre> aes128-cbc-hmac-sha1 aes192-cbc-hmac-sha1 aes256-cbc-hmac-sha1 3des-cbc-hmac-sha1 blowfish-cbc-hmac-sha1 aes128-cbc-hmac-md5 aes192-cbc-hmac-md5 aes256-cbc-hmac-md5 3des-cbc-hmac-md5 blowfish-cbc-hmac-md5 </pre> <p><i>Terminology:</i> DES – Data Encryption Standard (56-bit key) 3DES – Triple-DES (Uses three iterations of DES, 112-bit key) aes – Advanced Encryption Standard (160 or 224-bit key) blowfish – Blowfish (32-448 bit key) cbc – cypher-block chaining sha1 – Secure Hash Algorithm 1 (160-bit hashes) md5 – Message Digest algorithm number 5 (128-bit hashes)</p>

show public-key

This command shows the public key for the specified user or for the host.

Syntax

show public-key [**user** [*username*]] **host**

username – Name of an SSH user. (Range: 1-8 characters)

Default Setting

Shows all public keys.

Command Mode

Privileged Exec

Command Usage

- If no parameters are entered, all keys are displayed. If the user keyword is entered, but no user name is specified, then the public keys for all users are displayed.
- When an RSA key is displayed, the first field indicates the size of the host key (e.g., 1024), the second field is the encoded public exponent (e.g., 35), and the last string is the encoded modulus. When a DSA key is displayed, the first field indicates that the encryption method used by SSH is based on the Digital Signature Standard (DSS), and the last string is the encoded modulus.

Example

```

Console#show public-key host
Host:
RSA:
1024 35
1568499540186766925933394677505461732531367489083654725415020245593199868
5443583616519999233297817660658309586108259132128902337654680172627257141
3428762941301196195566782595664104869574278881462065194174677298486546861
5717739390164779355942303577413098022737087794545240839717526463580581767
16709574804776117
DSA:
ssh-dss AAAB3NzaC1kc3MAAACBAPWKZTPbsRIB8ydEXcxM3dyV/yrDbKStIlnzD/Dg0h2Hxc
YV44sXZ2JXhamLK6P8bvuiyacWbUW/a4PATp1KMSdqSkeh3hKoA3vRRSy1N2XFfAKx15fwFfv
JlPdOkFgzLGMInvSNYQwiQXbkTBH0Z4mUZpE85PWxDZMacNBpJBrAAAAFQChb4vsdfQGNiJw
bvwrnLaQ77isiwAAAIEAsy5YWDC99ebYHNRj5kh47wY4i8czvH+/p9cncrfwFTMU01VFDly3IR
2G395Nly5Qd7ZDxfA9mCoFt/yyEfbobMJZi8oGCst.SNOxrZZVnMqWrTYfdrKX7YKBw/Kjw6Bm
iFq70+jAhf1Dg45loAc27s6TLdtnylwRq/ow2eTCD5nekAAACBAJ8rMccXTxHLFAczWS7EjOy
DbsloBfPusAb4oAsyjKXKVYNLQkTLZfcFRu41bS2KV5LAWecsigF/+DjKGWtPNIQqabKgYcW2
o/dVzX4Gg+yqdTlYmGA7fHGm8ARGeiG4ssFKy4Z6DmYPXFum1Yg0fhLwuHpoSKdxT3kk475S7
w0W
Console#

```

Event Logging Commands

Table 4-18 Event Logging Commands

Command	Function	Mode	Page
logging on	Controls logging of error messages	GC	4-54
logging history	Limits syslog messages saved to switch memory based on severity	GC	4-55
logging host	Adds a syslog server host IP address that will receive logging messages	GC	4-56
logging facility	Sets the facility type for remote logging of syslog messages	GC	4-56
logging trap	Limits syslog messages saved to a remote server based on severity	GC	4-57
clear logging	Clears messages from the logging buffer	PE	4-57
show logging	Displays the state of logging	PE	4-58
show log	Displays log messages	PE	4-59

logging on

This command controls logging of error messages, sending debug or error messages to switch memory. The **no** form disables the logging process.

Syntax

[no] logging on

Default Setting

None

Command Mode

Global Configuration

Command Usage

The logging process controls error messages saved to switch memory. You can use the **logging history** command to control the type of error messages that are stored.

Example

```
Console(config)#logging on
Console(config)#
```

Related Commands

logging history (4-55)
clear logging (4-57)

logging history

This command limits syslog messages saved to switch memory based on severity. The **no** form returns the logging of syslog messages to the default level.

Syntax

logging history {flash | ram} level

no logging history {flash | ram}

- **flash** - Event history stored in flash memory (i.e., permanent memory).
- **ram** - Event history stored in temporary RAM (i.e., memory flushed on power reset).
- **level** - One of the levels listed below. Messages sent include the selected level down to level 0. (Range: 0-7)

Table 4-19 Logging Levels

Level	Severity Name	Description
7	debugging	Debugging messages
6	informational	Informational messages only
5	notifications	Normal but significant condition, such as cold start
4	warnings	Warning conditions (e.g., return false, unexpected return)
3	errors	Error conditions (e.g., invalid input, default used)
2	critical	Critical conditions (e.g., memory allocation, or free memory error - resource exhausted)
1	alerts	Immediate action needed
0	emergencies	System unusable

* There are only Level 2, 5 and 6 error messages for the current firmware release.

Default Setting

Flash: errors (level 3 - 0)

RAM: warnings (level 6 - 0)

Command Mode

Global Configuration

Command Usage

The message level specified for flash memory must be a higher priority (i.e., numerically lower) than that specified for RAM.

Example

```
Console(config)#logging history ram 0
Console(config)#
```

logging host

This command adds a syslog server host IP address that will receive logging messages. Use the **no** form to remove a syslog server host.

Syntax

[no] logging host *host_ip_address*

host_ip_address - The IP address of a syslog server.

Default Setting

None

Command Mode

Global Configuration

Command Usage

- By using this command more than once you can build up a list of host IP addresses.
- The maximum number of host IP addresses allowed is five.

Example

```
Console(config)#logging host 10.1.0.3
Console(config)#
```

logging facility

This command sets the facility type for remote logging of syslog messages. Use the **no** form to return the type to the default.

Syntax

[no] logging facility *type*

type - A number that indicates the facility used by the syslog server to dispatch log messages to an appropriate service. (Range: 16-23)

Default Setting

23

Command Mode

Global Configuration

Command Usage

The command specifies the facility type tag sent in syslog messages. (See RFC 3164.) This type has no effect on the kind of messages reported by the switch. However, it may be used by the syslog server to sort messages or to store messages in the corresponding database.

Example

```
Console(config)#logging facility 19
Console(config)#
```

logging trap

This command enables the logging of system messages to a remote server, or limits the syslog messages saved to a remote server based on severity. Use this command without a specified level to enable remote logging. Use the **no** form to disable remote logging.

Syntax

logging trap [*level*]
no logging trap

level - One of the level arguments listed below. Messages sent include the selected level up through level 0. (Refer to the table on page 4-55.)

Default Setting

- Enabled
- Level 6 - 0

Command Mode

Global Configuration

Command Usage

- Using this command with a specified level enables remote logging and sets the minimum severity level to be saved.
- Using this command without a specified level also enables remote logging, but restores the minimum severity level to the default.

Example

```
Console(config)#logging trap 4
Console(config)#
```

clear logging

This command clears messages from the log buffer.

Syntax

clear logging [**flash** | **ram**]

- **flash** - Event history stored in flash memory (i.e., permanent memory).
- **ram** - Event history stored in temporary RAM (i.e., memory flushed on power reset).

Default Setting

Flash and RAM

Command Mode

Privileged Exec

Example

```
Console#clear logging
Console#
```

Related Commands

show logging (4-58)

show logging

This command displays the configuration settings for logging messages to local switch memory, to an SMTP event handler, or to a remote syslog server.

Syntax

show logging {flash | ram | sendmail | trap}

- **flash** - Displays settings for storing event messages in flash memory (i.e., permanent memory).
- **ram** - Displays settings for storing event messages in temporary RAM (i.e., memory flushed on power reset).
- **sendmail** - Displays settings for the SMTP event handler (page 4-63).
- **trap** - Displays settings for the trap function.

Default Setting

None

Command Mode

Privileged Exec

Example

The following example shows that system logging is enabled, the message level for flash memory is “errors” (i.e., default level 3 - 0), the message level for RAM is “informational” (i.e., default level 6 - 0).

```
Console#show logging flash
Syslog logging:           Enabled
History logging in FLASH: level errors
Console#show logging ram
Syslog logging:           Enabled
History logging in RAM: level informational
Console#
```

Table 4-20 show logging flash/ram - display description

Field	Description
Syslog logging	Shows if system logging has been enabled via the logging on command.
History logging in FLASH	The message level(s) reported based on the logging history command.
History logging in RAM	The message level(s) reported based on the logging history command.

The following example displays settings for the trap function.

```

Console#show logging trap
Syslog logging: Enable
REMOTELOG status: disable
REMOTELOG facility type: local use 7
REMOTELOG level type: Debugging messages
REMOTELOG server IP address: 1.2.3.4
REMOTELOG server IP address: 0.0.0.0
REMOTELOG server IP address: 0.0.0.0
REMOTELOG server IP address: 0.0.0.0
REMOTELOG server IP address: 0.0.0.0
Console#

```

Table 4-21 show logging trap - display description

Field	Description
Syslog logging	Shows if system logging has been enabled via the logging on command.
REMOTELOG status	Shows if remote logging has been enabled via the logging trap command.
REMOTELOG facility type	The facility type for remote logging of syslog messages as specified in the logging facility command.
REMOTELOG level type	The severity threshold for syslog messages sent to a remote server as specified in the logging trap command.
REMOTELOG server IP address	The address of syslog servers as specified in the logging host command.

Related Commands

show logging sendmail (4-63)

show log

This command displays the system and event messages stored in memory.

Syntax

show log {flash | ram} [login] [tail]

- **flash** - Event history stored in flash memory (i.e., permanent memory).
- **ram** - Event history stored in temporary RAM (i.e., memory flushed on power reset).
- **tail** - Shows event history starting from the most recent entry.
- **login** - Shows the login record only.

Default Setting

None

Command Mode

Privileged Exec

Command Usage

This command shows the system and event messages stored in memory, including the time stamp, message level (page 4-55), program module, function, and event number.

Example

The following example shows sample messages stored in RAM.

```
Console#show log ram
[5] 00:01:06 2001-01-01
    "STA root change notification."
    level: 6, module: 6, function: 1, and event no.: 1
[4] 00:01:00 2001-01-01
    "STA root change notification."
    level: 6, module: 6, function: 1, and event no.: 1
[3] 00:00:54 2001-01-01
    "STA root change notification."
    level: 6, module: 6, function: 1, and event no.: 1
[2] 00:00:50 2001-01-01
    "STA topology change notification."
    level: 6, module: 6, function: 1, and event no.: 1
[1] 00:00:48 2001-01-01
    "VLAN 1 link-up notification."
    level: 6, module: 6, function: 1, and event no.: 1
Console#
```

SMTP Alert Commands

These commands configure SMTP event handling, and forwarding of alert messages to the specified SMTP servers and email recipients.

Table 4-22 SMTP Alert Commands

Command	Function	Mode	Page
logging sendmail host	SMTP servers to receive alert messages	GC	4-60
logging sendmail level	Severity threshold used to trigger alert messages	GC	4-61
logging sendmail source-email	Email address used for "From" field of alert messages	GC	4-62
logging sendmail destination-email	Email recipients of alert messages	GC	4-62
logging sendmail	Enables SMTP event handling	GC	4-63
show logging sendmail	Displays SMTP event handler settings	NE, PE	4-63

logging sendmail host

This command specifies SMTP servers that will be sent alert messages. Use the **no** form to remove an SMTP server.

Syntax

[no] logging sendmail host *ip_address*

ip_address - IP address of an SMTP server that will be sent alert messages for event handling.

Default Setting

None

Command Mode

Global Configuration

Command Usage

- You can specify up to three SMTP servers for event handing. However, you must enter a separate command to specify each server.
- To send email alerts, the switch first opens a connection, sends all the email alerts waiting in the queue one by one, and finally closes the connection.
- To open a connection, the switch first selects the server that successfully sent mail during the last connection, or the first server configured by this command. If it fails to send mail, the switch selects the next server in the list and tries to send mail again. If it still fails, the system will repeat the process at a periodic interval. (A trap will be triggered if the switch cannot successfully open a connection.)

Example

```
Console(config)#logging sendmail host 192.168.1.200
Console(config)#
```

logging sendmail level

This command sets the severity threshold used to trigger alert messages.

Syntax

logging sendmail level *level*

level - One of the system message levels (page 4-55). Messages sent include the selected level down to level 0. (Range: 0-7; Default: 7)

Default Setting

Level 7

Command Mode

Global Configuration

Command Usage

The specified level indicates an event threshold. All events at this level or higher will be sent to the configured email recipients. (For example, using Level 7 will report all events from level 7 to level 0.)

Example

This example will send email alerts for system errors from level 4 through 0.

```
Console(config)#logging sendmail level 4
Console(config)#
```

logging sendmail source-email

This command sets the email address used for the “From” field in alert messages. Use the **no** form to delete the source email address.

Syntax

[no] logging sendmail source-email *email-address*

email-address - The source email address used in alert messages.
(Range: 0-41 characters)

Default Setting

None

Command Mode

Global Configuration

Command Usage

You may use an symbolic email address that identifies the switch, or the address of an administrator responsible for the switch.

Example

This example will set the source email john@acme.com.

```
Console(config)#logging sendmail source-email john@acme.com
Console(config)#
```

logging sendmail destination-email

This command specifies the email recipients of alert messages. Use the **no** form to remove a recipient.

Syntax

[no] logging sendmail destination-email *email-address*

email-address - The source email address used in alert messages.
(Range: 1-41 characters)

Default Setting

None

Command Mode

Global Configuration

Command Usage

You can specify up to five recipients for alert messages. However, you must enter a separate command to specify each recipient.

Example

```
Console(config)#logging sendmail destination-email ted@this-company.com
Console(config)#
```

logging sendmail

This command enables SMTP event handling. Use the **no** form to disable this function.

Syntax

```
[no] logging sendmail
```

Default Setting

Enabled

Command Mode

Global Configuration

Example

```
Console(config)#logging sendmail
Console(config)#
```

show logging sendmail

This command displays the settings for the SMTP event handler.

Command Mode

Normal Exec, Privileged Exec

Example

```
Console#show logging sendmail
SMTP servers
-----
 1. 192.168.1.200

SMTP minimum severity level: 4

SMTP destination email addresses
-----
 1. geoff@acme.com

SMTP source email address:   john@acme.com

SMTP status:                 Enabled
Console#
```

Time Commands

The system clock can be dynamically set by polling a set of specified time servers (NTP or SNTP). Maintaining an accurate time on the switch enables the system log to record meaningful dates and times for event entries. If the clock is not set, the switch will only record the time from the factory default set at the last bootstrap.

Table 4-23 Time Commands

Command	Function	Mode	Page
sntp client	Accepts time from specified time servers	GC	4-64
sntp server	Specifies one or more time servers	GC	4-65
sntp poll	Sets the interval at which the client polls for time	GC	4-66
show sntp	Shows current SNTP configuration settings	NE, PE	4-66
ntp client	Enables the NTP client for time updates from specified servers	GC	4-67
ntp server	Specifies NTP servers to poll for time updates	GC	4-68
ntp poll	Sets the interval at which the NTP client polls for time	GC	4-69
ntp authenticate	Enables authentication for NTP traffic	GC	4-69
ntp authentication-key	Configures authentication keys	GC	4-70
show ntp	Shows current NTP configuration settings	NE, PE	4-71
clock timezone-predefined	Sets the time zone for the switch's internal clock using predefined time zone configurations	GC	4-71
clock timezone	Manually sets the time zone for the switch's internal clock	GC	4-72
clock summertime (date)	Configures summer time (daylight savings time) for the switch's internal clock	GC	4-73
clock summertime (predefined)	Configures summer time (daylight savings time) for the switch's internal clock	GC	4-74
clock summertime (recurring)	Configures summer time (daylight savings time) for the switch's internal clock	GC	4-75
calendar set	Sets the system date and time	PE	4-76
show calendar	Displays the current date and time setting	NE, PE	4-76

sntp client

This command enables SNTP client requests for time synchronization from NTP or SNTP time servers specified with the **sntp servers** command. Use the **no** form to disable SNTP client requests.

Syntax

[no] sntp client

Default Setting

Disabled

Command Mode

Global Configuration

Command Usage

- The time acquired from time servers is used to record accurate dates and times for log events. Without SNTP, the switch only records the time starting from the factory default set at the last bootup (i.e., 00:00:00, Jan. 1, 2001).
- This command enables client time requests to time servers specified via the **sntp servers** command. It issues time synchronization requests based on the interval set via the **sntp poll** command.

Example

```
Console(config)#sntp server 10.1.0.19
Console(config)#sntp poll 60
Console(config)#sntp client
Console(config)#end
Console#show sntp
Current time: Dec 23 02:52:44 2002
Poll interval: 60
Current mode: unicast
SNTP status: Enabled
SNTP server: 10.1.0.19 0.0.0.0 0.0.0.0
Current server: 10.1.0.19
Console#
```

Related Commands

- sntp server (4-65)
- sntp poll (4-66)
- show sntp (4-66)

sntp server

This command sets the IP address of the servers to which SNTP time requests are issued. Use the this command with no arguments to clear all time servers from the current list.

Syntax

```
sntp server [ip1 [ip2 [ip3]]]
```

ip - IP address of a time server (NTP or SNTP).
(Range: 1-3 addresses)

Default Setting

None

Command Mode

Global Configuration

Command Usage

This command specifies time servers from which the switch will poll for time updates when set to SNTP client mode. The client will poll the time servers in the order specified until a response is received. It issues time synchronization requests based on the interval set via the **sntp poll** command.

Example

```
Console(config)#ntp server 10.1.0.19
```

Related Commands

- ntp client (4-64)
- ntp poll (4-66)
- show ntp (4-66)

ntp poll

This command sets the interval between sending time requests when the switch is set to SNTP client mode. Use the **no** form to restore to the default.

Syntax

```
ntp poll seconds  
no ntp poll
```

seconds - Interval between time requests. (Range: 16-16384 seconds)

Default Setting

16 seconds

Command Mode

Global Configuration

Example

```
Console(config)#ntp poll 60  
Console(config)#
```

Related Commands

- ntp client (4-64)

show ntp

This command displays the current time and configuration settings for the SNTP client, and indicates whether or not the local time has been properly updated.

Command Mode

Normal Exec, Privileged Exec

Command Usage

This command displays the current time, the poll interval used for sending time synchronization requests, and the current SNTP mode (i.e., unicast).

Example

```
Console#show sntp
Current time: Dec 23 05:13:28 2002
Poll interval: 16
Current mode: unicast
SNTP status : Enabled
SNTP server 137.92.140.80 0.0.0.0 0.0.0.0
Current server: 137.92.140.80
Console#
```

ntp client

This command enables NTP client requests for time synchronization from NTP time servers specified with the **ntp servers** command. Use the **no** form to disable NTP client requests.

Syntax

[no] ntp client

Default Setting

Disabled

Command Mode

Global Configuration

Command Usage

- The SNTP and NTP clients cannot be enabled at the same time. First disable the SNTP client before using this command.
- The time acquired from time servers is used to record accurate dates and times for log events. Without NTP, the switch only records the time starting from the factory default set at the last bootup (i.e., 00:00:00, Jan. 1, 2001).
- This command enables client time requests to time servers specified via the **ntp servers** command. It issues time synchronization requests based on the interval set via the **ntp poll** command.

Example

```
Console(config)#ntp client
Console(config)#
```

Related Commands

snmp client (4-64)
ntp poll (4-69)
ntp server (4-68)

ntp server

This command sets the IP addresses of the servers to which NTP time requests are issued. Use the **no** form of the command to clear a specific time server or all servers from the current list.

Syntax

ntp server *ip-address* [**version** *number*] [**key** *key-number*]

no ntp server [*ip-address*]

- *ip-address* - IP address of an NTP time server.
- *number* - The NTP version number supported by the server. (Range: 1-3)
- *key-number* - The number of an authentication key to use in communications with the server. (Range: 1-65535)

Default Setting

Version number: 3

Command Mode

Global Configuration

Command Usage

- This command specifies time servers that the switch will poll for time updates when set to NTP client mode. It issues time synchronization requests based on the interval set with the **ntp poll** command. The client will poll all the time servers configured, the responses received are filtered and compared to determine the most reliable and accurate time update for the switch.
- You can configure up to 50 NTP servers on the switch. Re-enter this command for each server you want to configure.
- NTP authentication is optional. If enabled with the **ntp authenticate** command, you must also configure at least one key number using the **ntp authentication-key** command.
- Use the **no** form of this command without an argument to clear all configured servers in the list.

Example

```
Console(config)#ntp server 192.168.3.20
Console(config)#ntp server 192.168.3.21
Console(config)#ntp server 192.168.4.22 version 2
Console(config)#ntp server 192.168.5.23 version 3 key 19
Console(config)#
```

Related Commands

ntp client (4-67)

ntp poll (4-69)

show ntp (4-71)

ntp poll

This command sets the interval between sending time requests when the switch is set to NTP client mode. Use the **no** form to restore to the default.

Syntax

```
ntp poll seconds  
no ntp poll
```

seconds - Interval between time requests. (Range: 16-16384 seconds)

Default Setting

16 seconds

Command Mode

Global Configuration

Example

```
Console(config)#ntp poll 60  
Console(config)#
```

Related Commands

ntp client (4-67)

ntp authenticate

This command enables authentication for NTP client-server communications. Use the **no** form to disable authentication.

Syntax

```
[no] ntp authenticate
```

Default Setting

Disabled

Command Mode

Global Configuration

Command Usage

You can enable NTP authentication to ensure that reliable updates are received from only authorized NTP servers. The authentication keys and their associated key number must be centrally managed and manually distributed to NTP servers and clients. The key numbers and key values must match on both the server and client.

Example

```
Console(config)#ntp authenticate
Console(config)#
```

Related Commands

ntp authentication-key (4-70)

ntp authentication-key

This command configures authentication keys and key numbers to use when NTP authentication is enabled. Use the **no** form of the command to clear a specific authentication key or all keys from the current list.

Syntax

```
ntp authentication-key number md5 key
no ntp authentication-key [number]
```

- *number* - The NTP authentication key ID number. (Range: 1-65535)
- **md5** - Specifies that authentication is provided by using the message digest algorithm 5.
- *key* - An MD5 authentication key string. The key string can be up to 32 case-sensitive printable ASCII characters (no spaces).

Default Setting

None

Command Mode

Global Configuration

Command Usage

- The key number specifies a key value in the NTP authentication key list. Up to 255 keys can be configured on the switch. Re-enter this command for each server you want to configure.
- Note that NTP authentication key numbers and values must match on both the server and client.
- NTP authentication is optional. When enabled with the **ntp authenticate** command, you must also configure at least one key number using this command.
- Use the **no** form of this command without an argument to clear all authentication keys in the list.

Example

```
Console(config)#ntp authentication-key 45 md5 thisiskey45
Console(config)#
```

Related Commands

ntp authenticate (4-69)

show ntp

This command displays the current time and configuration settings for the NTP client, and indicates whether or not the local time has been properly updated.

Command Mode

Normal Exec, Privileged Exec

Command Usage

This command displays the current time, the poll interval used for sending time synchronization requests, and the current NTP mode (i.e., unicast).

Example

```
Console#show ntp
Current time: Jan 1 02:58:58 2001
Poll interval: 16
Current mode: unicast
NTP status : Enabled          NTP Authenticate status : Enabled
Last Update NTP Server: 0.0.0.0      Port: 0
Last Update time: Dec 31 00:00:00 2000 UTC
NTP Server 192.168.3.20 version 3
NTP Server 192.168.3.21 version 3
NTP Server 192.168.3.22 version 2
NTP Server 192.168.4.50 version 3 key 30
NTP Server 192.168.5.35 version 3 key 19
NTP Authentication-Key 12 md5 156S46Q24142414222711K66N80 7
NTP Authentication-Key 19 md5 Q33016Q6338241J022S29Q731K7 7
NTP Authentication-Key 30 md5 D2V8777I51K1132K3552L26R614104 7
NTP Authentication-Key 45 md5 3U865531013K38F0R8 7
NTP Authentication-Key 125 md5 A48S2810327947M76 7
Console#
```

clock timezone-predefined

This command uses predefined time zone configurations to set the time zone for the switch's internal clock. Use the **no** form to restore the default.

Syntax

clock timezone-predefined *offset-city*

no clock timezone-predefined

- *offset* - Select the offset from GMT. (Range: GMT-0100 - GMT-1200; GMT-Greenwich-Mean-Time; GMT+0100 - GMT+1300)
- *city* - Select the city associated with the chosen GMT offset. After the offset has been entered, use the tab-complete function to display the available city options.

Default Setting

GMT-Greenwich-Mean-Time-Dublin,Edinburgh,Lisbon,London

Command Mode

Global Configuration

Command Usage

This command sets the local time zone relative to the Coordinated Universal Time (UTC, formerly Greenwich Mean Time or GMT), based on the earth's prime meridian, zero degrees longitude. To display a time corresponding to your local time, you must indicate the number of hours and minutes your time zone is east (before) or west (after) of UTC.

Example

```
Console(config)#clock timezone-predefined GMT-0930-Taiohae
Console(config)#
```

Related Commands

show sntp (4-66)

clock timezone

This command sets the time zone for the switch's internal clock.

Syntax

clock timezone *name* *hour* *hours* *minute* *minutes* {**before-utc** | **after-utc**}

- *name* - Name of timezone, usually an acronym. (Range: 1-29 characters)
- *hours* - Number of hours before/after UTC. (Range: 0-12 hours)
- *minutes* - Number of minutes before/after UTC. (Range: 0-59 minutes)
- **before-utc** - Sets the local time zone before (east) of UTC.
- **after-utc** - Sets the local time zone after (west) of UTC.

Default Setting

None

Command Mode

Global Configuration

Command Usage

This command sets the local time zone relative to the Coordinated Universal Time (UTC, formerly Greenwich Mean Time or GMT), based on the earth's prime meridian, zero degrees longitude. To display a time corresponding to your local time, you must indicate the number of hours and minutes your time zone is east (before) or west (after) of UTC.

Example

```
Console(config)#clock timezone Japan hours 8 minute 0 after-UTC
Console(config)#
```

Related Commands

show sntp (4-66)

clock summer-time (date)

This command allows the user to manually configure the start, end, and offset times of summer-time (daylight savings time) for the switch on a one-time basis. Use the **no** form to disable summer-time.

Syntax

clock summer-time *name date b-month b-day b-year b-hour b-minute
e-month e-day e-year e-hour e-minute offset*

no clock summer-time

- *name* - Name of the time zone while summer-time is in effect, usually an acronym. (Range: 1-30 characters)
- *b-month* - The month when summer-time will begin. (Options: **january** | **february** | **march** | **april** | **may** | **june** | **july** | **august** | **september** | **october** | **november** | **december**)
- *b-day* - The day summer-time will begin. (Options: **sunday** | **monday** | **tuesday** | **wednesday** | **thursday** | **friday** | **saturday**)
- *b-year* - The year summer-time will begin.
- *b-hour* - The hour summer-time will begin. (Range: 0-23 hours)
- *b-minute* - The minute summer-time will begin. (Range: 0-59 minutes)
- *e-month* - The month when summer-time will end. (Options: **january** | **february** | **march** | **april** | **may** | **june** | **july** | **august** | **september** | **october** | **november** | **december**)
- *e-day* - The day summer-time will end. (Options: **sunday** | **monday** | **tuesday** | **wednesday** | **thursday** | **friday** | **saturday**)
- *e-year* - The year summer-time will end.
- *e-hour* - The hour summer-time will end. (Range: 0-23 hours)
- *e-minute* - The minute summer-time will end. (Range: 0-59 minutes)
- *offset* - Summer-time offset from the regular time zone, in minutes. (Range: 0-99 minutes)

Default Setting

Disabled

Command Mode

Global Configuration

Command Usage

This command sets the summer-time time zone relative to the currently configured time zone. To display a time corresponding to your local time when summer-time is in effect, you must indicate the number of minutes your summer-time time zone deviates from your regular time zone.

Example

```
Console(config)#clock summer-time DEST date april 1 2007 23 23 april 23
2007 23 23 60
Console(config)#
```

Related Commands

show sntp (4-66)

clock summer-time (predefined)

This command configures the summer time (daylight savings time) status and settings for the switch using predefined configurations for several major regions of the world. Use the **no** form to disable summer time.

Syntax

```
clock summer-time name predefined [australia | europe | new-zealand |
usa]
no clock summer-time
```

- *name* - Name of the timezone while summer time is in effect, usually an acronym. (Range: 1-30 characters)

Default Setting

Disabled

Command Mode

Global Configuration

Command Usage

This command sets the summer-time time relative to the configured time zone. To display the time corresponding to your local time when summer-time is in effect, select the predefined summer-time time zone appropriate for your location, or manually configure summer-time if these predefined configurations do not apply to your location (see “clock summer-time (date)” on page 4-73 or “clock summer-time (recurring)” on page 4-75).

Table 4-24 Predefined Summer-Time Parameters

Region	Start Time, Day, Week, & Month	End Time, Day, Week, & Month	Rel. Offset
Australia	00:00:00, Sunday, Week 5 of October	23:59:59, Sunday, Week 5 of March	60 min
Europe	00:00:00, Sunday, Week 5 of March	23:59:59, Sunday, Week 5 of October	60 min
New Zealand	00:00:00, Sunday, Week 1 of October	23:59:59, Sunday, Week 3 of March	60 min
USA	02:00:00, Sunday, Week 2 of March	02:00:00, Sunday, Week 1 of November	60 min

Example

```
Console(config)#clock summer-time MESZ predefined europe
Console(config)#
```

Related Commands

show sntp (4-66)

clock summer-time (recurring)

This command allows the user to manually configure the start, end, and offset times of summer-time (daylight savings time) for the switch on a recurring basis. Use the **no** form to disable summer-time.

Syntax

clock summer-time *name recurring b-week b-day b-month b-hour b-minute e-week e-day e-month e-hour e-minute offset*

no clock summer-time

- *name* - Name of the timezone while summer time is in effect, usually an acronym. (Range: 1-30 characters)
- *b-week* - The week of the month when summer-time will begin. (Range: 1-5)
- *b-day* - The day of the week when summer-time will begin. (Options: **sunday** | **monday** | **tuesday** | **wednesday** | **thursday** | **friday** | **saturday**)
- *b-month* - The month when summer-time will begin. (Options: **january** | **february** | **march** | **april** | **may** | **june** | **july** | **august** | **september** | **october** | **november** | **december**)
- *b-hour* - The hour when summer-time will begin. (Range: 0-23 hours)
- *b-minute* - The minute when summer-time will begin. (Range: 0-59 minutes)
- *e-week* - The week of the month when summer-time will end. (Range: 1-5)
- *e-day* - The day of the week summer-time will end. (Options: **sunday** | **monday** | **tuesday** | **wednesday** | **thursday** | **friday** | **saturday**)
- *e-month* - The month when summer-time will end. (Options: **january** | **february** | **march** | **april** | **may** | **june** | **july** | **august** | **september** | **october** | **november** | **december**)
- *e-hour* - The hour when summer-time will end. (Range: 0-23 hours)
- *e-minute* - The minute when summer-time will end. (Range: 0-59 minutes)
- *offset* - Summer-time offset from the regular time zone, in minutes. (Range: 0-99 minutes)

Default Setting

Disabled

Command Mode

Global Configuration

Command Usage

This command sets the summer-time time zone relative to the currently configured time zone. To display a time corresponding to your local time when summer-time is in effect, you must indicate the number of minutes your summer-time time zone deviates from your regular time zone.

4 Command Line Interface

Example

```
Console(config)#clock summer-time MESZ recurring 1 friday june 23 59 3
saturday september 2 55 60
Console(config)#
```

Related Commands

show sntp (4-66)

calendar set

This command sets the system clock. It may be used if there is no time server on your network, or if you have not configured the switch to receive signals from a time server.

Syntax

calendar set *hour min sec {day month year | month day year}*

- *hour* - Hour in 24-hour format. (Range: 0-23)
- *min* - Minute. (Range: 0-59)
- *sec* - Second. (Range: 0-59)
- *day* - Day of month. (Range: 1-31)
- *month* - **january | february | march | april | may | june | july | august | september | october | november | december**
- *year* - Year (4-digit). (Range: 2001-2100)

Default Setting

None

Command Mode

Privileged Exec

Example

```
Console#calendar set 15 12 34 1 April 2004
Console#
```

show calendar

This command displays the system clock.

Default Setting

None

Command Mode

Normal Exec, Privileged Exec

Example

```
Console#show calendar
15:12:43 April 1 2004
Console#
```

System Status Commands

Table 4-25 System Status Commands

Command	Function	Mode	Page
show startup-config	Displays the contents of the configuration file (stored in flash memory) that is used to start up the system	PE	4-77
show running-config	Displays the configuration data currently in use	PE	4-78
show system	Displays system information	NE, PE	4-81
show users	Shows all active console and Telnet sessions, including user name, idle time, and IP address of Telnet clients	NE, PE	4-81
show version	Displays version information for the system	NE, PE	4-82

show startup-config

This command displays the configuration file stored in non-volatile memory that is used to start up the system.

Default Setting

None

Command Mode

Privileged Exec

Command Usage

- Use this command in conjunction with the **show running-config** command to compare the information in running memory to the information stored in non-volatile memory.
- This command displays settings for key command modes. Each mode group is separated by “!” symbols, and includes the configuration mode command, and corresponding commands. This command displays the following information:
 - SNMP community strings
 - Users (names and access levels)
 - VLAN database (VLAN ID, name and state)
 - VLAN configuration settings for each interface
 - IP address configured for the switch
 - Spanning tree settings
 - Any configured settings for the console port and Telnet

Example

```
Console#show startup-config
building startup-config, please wait.....
!
!
username admin access-level 15
username admin password 0 admin
!
username guest access-level 0
username guest password 0 guest
!
enable password level 15 0 super
!
snmp-server community public ro
snmp-server community private rw
!
logging history ram 6
logging history flash 3
!
vlan database
  vlan 1 name DefaultVlan media ethernet state active
!
interface ethernet 1/1
  switchport allowed vlan add 1 untagged
  switchport native vlan 1
:
:
interface vlan 1
  ip address dhcp
!
line console
!
line vty
!
end
Console#
```

Related Commands

show running-config (4-78)

show running-config

This command displays the configuration information currently in use.

Default Setting

None

Command Mode

Privileged Exec

Command Usage

- Use this command in conjunction with the **show startup-config** command to compare the information in running memory to the information stored in non-volatile memory.
- This command displays settings for key command modes. Each mode group

is separated by “!” symbols, and includes the configuration mode command, and corresponding commands. This command displays the following information:

- MAC address for each switch in the stack
- SNTP server settings
- Local time zone
- SNMP community strings
- Users (names, access levels, and encrypted passwords)
- Event log settings
- VLAN database (VLAN ID, name and state)
- VLAN configuration settings for each interface
- IP address configured for the switch
- Layer 4 precedence settings
- Any configured settings for the console port and Telnet

Example

```
Console#show running-config
building startup-config, please wait.....
!
phymap 00-12-cf-ce-2a-20 00-00-00-00-00-00 00-00-00-00-00-00
00-00-00-00-00-00 00-00-00-00-00-00 00-00-00-00-00-00 00-00-00-00-00-00
00-00-00-00-00-00
!
SNTP server 0.0.0.0 0.0.0.0 0.0.0.0
!
clock timezone hours 0 minute 0 after-UTC
!
!
SNMP-server community private rw
SNMP-server community public ro
!
!
username admin access-level 15
username admin password 7 21232f297a57a5a743894a0e4a801fc3
username guest access-level 0
username guest password 7 084e0343a0486ff05530df6c705c8bb4
enable password level 15 7 1b3231655cebb7a1f783eddf27d254ca
!
!
logging history ram 6
logging history flash 3
!
!
vlan database
vlan 1 name DefaultVlan media ethernet state active
!
!
interface ethernet 1/1
switchport allowed vlan add 1 untagged
switchport native vlan 1
.
.
interface VLAN 1
IP address DHCP
!
no map IP DSCP
!
!
line console
!
line vty
!
end

Console#
```

Related Commands

show startup-config (4-77)

show system

This command displays system information.

Default Setting

None

Command Mode

Normal Exec, Privileged Exec

Command Usage

- For a description of the items shown by this command, refer to “Displaying System Information” on page 3-12.
- The POST results should all display “PASS.” If any POST test indicates “FAIL,” contact your distributor for assistance.

Example

```
Console#show system
System Description: TL-SL5428
System OID String: 1.3.6.1.4.1.11863.1.1.59
System Information
  System Up Time:          0 days, 0 hours, 1 minutes, and 32.18 seconds
  System Name:             [NONE]
  System Location:        [NONE]
  System Contact:         [NONE]
  MAC Address (Unit1):    00-00-35-28-10-03
  Web Server:             Enabled
  Web Server Port:       80
  Web Secure Server:     Enabled
  Web Secure Server Port: 443
  Telnet Server:         Enable
  Telnet Server Port:    23
  Jumbo Frame:          Disabled

  POST Result:
  DUMMY Test 1 ..... PASS
  UART Loopback Test ..... PASS
  DRAM Test ..... PASS
  Timer Test ..... PASS
  Switch Int Loopback Test ..... PASS

Done All Pass.
Console#
```

show users

Shows all active console and Telnet sessions, including user name, idle time, and IP address of Telnet client.

Default Setting

None

Command Mode

Normal Exec, Privileged Exec

Command Usage

The session used to execute this command is indicated by a “*” symbol next to the Line (i.e., session) index number.

Example

```
Console#show users
Username accounts:
  Username Privilege Public-Key
  -----
      admin          15      None
      guest           0      None
      steve           15      RSA

Online users:
  Line      Username Idle time (h:m:s) Remote IP addr.
  -----
  0 console  admin      0:14:14
* 1 VTY 0    admin      0:00:00   192.168.1.19
  2 SSH 1    steve      0:00:06   192.168.1.19

Web online users:
  Line      Remote IP addr Username Idle time (h:m:s).
  -----
  1 HTTP    192.168.1.19  admin      0:00:00

Console#
```

show version

This command displays hardware and software version information for the system.

Default Setting

None

Command Mode

Normal Exec, Privileged Exec

Command Usage

See “Displaying Switch Hardware/Software Versions” on page 3-13 for detailed information on the items displayed by this command.

Example

```

Console#show version
Unit1
  Serial number:          S416000937
  Service tag:
  Hardware version:      R01
  Module A type:         1000BaseT
  Module B type:         1000BaseT
  Number of ports:       28
  Main power status:     up
  Redundant power status :not present

Agent (master)
  Unit ID:                1
  Loader version:         2.2.1.4
  Boot ROM version:       2.2.1.8
  Operation code version: 2.2.7.1

Console#

```

Frame Size Commands**Table 4-26 Frame Size Commands**

Command	Function	Mode	Page
jumbo frame	Enables support for jumbo frames	GC	4-83

jumbo frame

This command enables support for jumbo frames. Use the **no** form to disable it.

Syntax

[no] jumbo frame

Default Setting

Disabled

Command Mode

Global Configuration

Command Usage

- This switch provides more efficient throughput for large sequential data transfers by supporting jumbo frames up to 9216 bytes. Compared to standard Ethernet frames that run only up to 1.5 KB, using jumbo frames significantly reduces the per-packet overhead required to process protocol encapsulation fields.
- To use jumbo frames, both the source and destination end nodes (such as a computer or server) must support this feature. Also, when the connection is operating at full duplex, all switches in the network between the two end nodes must be able to accept the extended frame size. And for half-duplex connections, all devices in the collision domain would need to support jumbo frames.

4 Command Line Interface

- Enabling jumbo frames will limit the maximum threshold for broadcast storm control to 64 packets per second. (See the **switchport broadcast** command on page 4-172.)
- The current setting for jumbo frames can be displayed with the show system command (page 4-81).

Example

```
Console(config)#jumbo frame
Console(config)#
```

Flash/File Commands

These commands are used to manage the system code or configuration files.

Table 4-27 Flash/File Commands

Command	Function	Mode	Page
copy	Copies a code image or a switch configuration to or from flash memory or a TFTP server	PE	4-84
delete	Deletes a file or code image	PE	4-87
dir	Displays a list of files in flash memory	PE	4-88
whichboot	Displays the files booted	PE	4-89
boot system	Specifies the file or image used to start up the system	GC	4-89

copy

This command moves (upload/download) a code image or configuration file between the switch's flash memory and a TFTP server. When you save the system code or configuration settings to a file on a TFTP server, that file can later be downloaded to the switch to restore system operation. The success of the file transfer depends on the accessibility of the TFTP server and the quality of the network connection.

Syntax

```
copy file {file | running-config | startup-config | tftp | unit}
copy running-config {file | startup-config | tftp}
copy startup-config {file | running-config | tftp}
copy tftp {file | running-config | startup-config | https-certificate |
public-key}
copy unit file
```

- **file** - Keyword that allows you to copy to/from a file.
- **running-config** - Keyword that allows you to copy to/from the current running configuration.
- **startup-config** - The configuration used for system initialization.
- **tftp** - Keyword that allows you to copy to/from a TFTP server.

- **https-certificate** - Copies an HTTPS certificate from an TFTP server to the switch.
- **public-key** - Keyword that allows you to copy a SSH key from a TFTP server. (“Secure Shell Commands” on page 4-45)
- **unit** - Keyword that allows you to copy to/from a unit.

Default Setting

None

Command Mode

Privileged Exec

Command Usage

- The system prompts for data required to complete the copy command.
- The destination file name should not contain slashes (\ or /), the leading letter of the file name should not be a period (.), and the maximum length for file names on the TFTP server is 127 characters or 31 characters for files on the switch. (Valid characters: A-Z, a-z, 0-9, “.”, “-”, “_”)
- Due to the size limit of the flash memory, the switch supports only two operation code files.
- The maximum number of user-defined configuration files depends on available memory.
- You can use “Factory_Default_Config.cfg” as the source to copy from the factory default configuration file, but you cannot use it as the destination.
- To replace the startup configuration, you must use **startup-config** as the destination.
- Use the **copy file unit** command to copy a local file to another switch in the stack. Use the **copy unit file** command to copy a file from another switch in the stack.
- The Boot ROM and Loader cannot be uploaded or downloaded from the TFTP server. You must follow the instructions in the release notes for new firmware, or contact your distributor for help.
- For information on specifying an https-certificate, see “Replacing the Default Secure-site Certificate” on page 3-70. For information on configuring the switch to use HTTPS for a secure connection, see “ip http secure-server” on page 4-42.

Example

The following example shows how to upload the configuration settings to a file on the TFTP server:

```
Console#copy file tftp
Choose file type:
 1. config:  2. opcode: <1-2>: 1
Source file name: startup
TFTP server ip address: 10.1.0.99
Destination file name: startup.01
TFTP completed.
Success.

Console#
```

The following example shows how to copy the running configuration to a startup file.

```
Console#copy running-config file
destination file name: startup
Write to FLASH Programming.
\Write to FLASH finish.
Success.

Console#
```

The following example shows how to download a configuration file:

```
Console#copy tftp startup-config
TFTP server ip address: 10.1.0.99
Source configuration file name: startup.01
Startup configuration file name [startup]:
Write to FLASH Programming.

\Write to FLASH finish.
Success.

Console#
```

This example shows how to copy a secure-site certificate from an TFTP server. It then reboots the switch to activate the certificate:

```
Console#copy tftp https-certificate
TFTP server ip address: 10.1.0.19
Source certificate file name: SS-certificate
Source private file name: SS-private
Private password: *****

Success.
Console#reload
System will be restarted, continue <y/n>? y
```

This example shows how to copy a public-key used by SSH from a TFTP server. Note that public key authentication via SSH is only supported for users configured locally on the switch:

```
Console#copy tftp public-key
TFTP server IP address: 192.168.1.19
Choose public key type:
 1. RSA:  2. DSA: <1-2>: 1
Source file name: steve.pub
Username: steve
TFTP Download
Success.
Write to FLASH Programming.
Success.

Console#
```

delete

This command deletes a file or image.

Syntax

delete [*unit*:] *filename*

filename - Name of the configuration file or image name.

unit - Stack unit. (Range: 1)

Default Setting

None

Command Mode

Privileged Exec

Command Usage

- If the file type is used for system startup, then this file cannot be deleted.
- "Factory_Default_Config.cfg" cannot be deleted.
- A colon (:) is required after the specified unit number.

Example

This example shows how to delete the test2.cfg configuration file from flash memory for unit 1.

```
Console#delete 1:test2.cfg
Console#
```

Related Commands

dir (4-88)

delete public-key (4-49)

dir

This command displays a list of files in flash memory.

Syntax

dir [*unit*:] {{**boot-rom**: | **config**: | **opcode**:} [*filename*]}

The type of file or image to display includes:

- **boot-rom** - Boot ROM (or diagnostic) image file.
- **config** - Switch configuration file.
- **opcode** - Run-time operation code image file.
- *filename* - Name of the configuration file or code image.
- *unit* - Stack unit. (Range: 1)

Default Setting

None

Command Mode

Privileged Exec

Command Usage

- If you enter the command **dir** without any parameters, the system displays all files.
- A colon (:) is required after the specified unit number.
- File information is shown below:

Table 4-28 File Directory Information

Column Heading	Description
file name	The name of the file.
file type	File types: Boot-Rom, Operation Code, and Config file.
startup	Shows if this file is used when the system is started.
size	The length of the file in bytes.

Example

The following example shows how to display all file information:

```
Console#dir 1:
      file name                file type      startup size (byte)
-----
      D2218                    Boot-Rom image Y           214124
      V2271                    Operation Code Y          1761944
      Factory_Default_Config.cfg Config File    Y             5197
-----
                                          Total free space: 5242880
Console#
```

whichboot

This command displays which files were booted when the system powered up.

Syntax

whichboot [*unit*]

unit - Stack unit. (Range: 1)

Default Setting

None

Command Mode

Privileged Exec

Example

This example shows the information displayed by the **whichboot** command. See the table under the **dir** command for a description of the file information displayed by this command.

```

Console#whichboot
      file name                file type      startup size (byte)
-----
Unit1:
      TL-SL5428_V1.0.0.8.bix   Boot-Rom image Y           214124
      TL-SL5428_V1.3.0.2.bix   Operation Code Y          1761944
      Startup1.cfg             Config File    Y             5197
Console#

```

boot system

This command specifies the image used to start up the system.

Syntax

boot system [*unit*:] {**boot-rom** | **config** | **opcode**}: *filename*

The type of file or image to set as a default includes:

- **boot-rom*** - Boot ROM.
- **config*** - Configuration file.
- **opcode*** - Run-time operation code.
- *filename* - Name of the configuration file or code image.
- *unit** - Specifies the unit number. (Range: 1)

* The colon (:) is required.

Default Setting

None

Command Mode

Global Configuration

Command Usage

- A colon (:) is required after the specified unit number and file type.
- If the file contains an error, it cannot be set as the default file.

Example

```
Console(config)#boot system config: startup  
Console(config)#
```

Related Commands

dir (4-88)

whichboot (4-89)

Authentication Commands

You can configure this switch to authenticate users logging into the system for management access using local or RADIUS authentication methods. You can also enable port-based authentication for network client access using IEEE 802.1X.

Table 4-29 Authentication Commands

Command Group	Function	Page
Authentication Sequence	Defines logon authentication method and precedence	4-90
RADIUS Client	Configures settings for authentication via a RADIUS server	4-93
TACACS+ Client	Configures settings for authentication via a TACACS+ server	4-97
AAA	Configures authentication, authorization, and accounting for network access	4-101
Port Security	Configures secure addresses for a port	4-110
Port Authentication	Configures host authentication on specific ports using 802.1X	4-111
Network Access	Configures MAC authentication and dynamic VLAN assignment	4-120
Web Authentication	Configures Web authentication	4-129

Authentication Sequence

Table 4-30 Authentication Sequence

Command	Function	Mode	Page
authentication login	Defines logon authentication method and precedence	GC	4-91
authentication enable	Defines the authentication method and precedence for command mode change	GC	4-92

authentication login

This command defines the login authentication method and precedence. Use the **no** form to restore the default.

Syntax

```
authentication login {[local] [radius] [tacacs]}  
no authentication login
```

- **local** - Use local password.
- **radius** - Use RADIUS server password.
- **tacacs** - Use TACACS server password.

Default Setting

Local

Command Mode

Global Configuration

Command Usage

- RADIUS uses UDP while TACACS+ uses TCP. UDP only offers best effort delivery, while TCP offers a connection-oriented transport. Also, note that RADIUS encrypts only the password in the access-request packet from the client to the server, while TACACS+ encrypts the entire body of the packet.
- RADIUS and TACACS+ logon authentication assigns a specific privilege level for each user name and password pair. The user name, password, and privilege level must be configured on the authentication server.
- You can specify three authentication methods in a single command to indicate the authentication sequence. For example, if you enter “**authentication login radius tacacs local**,” the user name and password on the RADIUS server is verified first. If the RADIUS server is not available, then authentication is attempted on the TACACS+ server. If the TACACS+ server is not available, the local user name and password is checked.

Example

```
Console(config)#authentication login radius  
Console(config)#
```

Related Commands

username - for setting the local user names and passwords (4-37)

authentication enable

This command defines the authentication method and precedence to use when changing from Exec command mode to Privileged Exec command mode with the **enable** command (see page 4-20). Use the **no** form to restore the default.

Syntax

authentication enable {[local] [radius] [tacacs]}

no authentication enable

- **local** - Use local password only.
- **radius** - Use RADIUS server password only.
- **tacacs** - Use TACACS server password.

Default Setting

Local

Command Mode

Global Configuration

Command Usage

- RADIUS uses UDP while TACACS+ uses TCP. UDP only offers best effort delivery, while TCP offers a connection-oriented transport. Also, note that RADIUS encrypts only the password in the access-request packet from the client to the server, while TACACS+ encrypts the entire body of the packet.
- RADIUS and TACACS+ logon authentication assigns a specific privilege level for each user name and password pair. The user name, password, and privilege level must be configured on the authentication server.
- You can specify three authentication methods in a single command to indicate the authentication sequence. For example, if you enter "**authentication enable radius tacacs local**," the user name and password on the RADIUS server is verified first. If the RADIUS server is not available, then authentication is attempted on the TACACS+ server. If the TACACS+ server is not available, the local user name and password is checked.

Example

```
Console(config)#authentication enable radius
Console(config)#
```

Related Commands

enable password - sets the password for changing command modes (4-38)

RADIUS Client

Remote Authentication Dial-in User Service (RADIUS) is a logon authentication protocol that uses software running on a central server to control access to RADIUS-aware devices on the network. An authentication server contains a database of multiple user name/password pairs with associated privilege levels for each user or group that require management access to a switch.

Table 4-31 RADIUS Client Commands

Command	Function	Mode	Page
radius-server host	Specifies the RADIUS server	GC	4-94
radius-server acct-port	Sets the RADIUS server network port	GC	4-94
radius-server auth-port	Sets the RADIUS server network port	GC	4-95
radius-server key	Sets the RADIUS encryption key	GC	4-95
radius-server retransmit	Sets the number of retries	GC	4-96
radius-server timeout	Sets the interval between sending authentication requests	GC	4-96
show radius-server	Shows the current RADIUS settings	PE	4-96

radius-server host

This command specifies primary and backup RADIUS servers and authentication parameters that apply to each server. Use the **no** form to restore the default values.

Syntax

```
[no] radius-server index host {host_ip_address | host_alias}  
[auth-port auth_port] [timeout timeout] [retransmit retransmit] [key key]
```

- *index* - Allows you to specify up to five servers. These servers are queried in sequence until a server responds or the retransmit period expires.
- *host_ip_address* - IP address of server.
- *host_alias* - Symbolic name of server. (Maximum length: 20 characters)
- *port_number* - RADIUS server UDP port used for authentication messages. (Range: 1-65535)
- *timeout* - Number of seconds the switch waits for a reply before resending a request. (Range: 1-65535)
- *retransmit* - Number of times the switch will try to authenticate logon access via the RADIUS server. (Range: 1-30)
- *key* - Encryption key used to authenticate logon access for client. Do not use blank spaces in the string. (Maximum length: 20 characters)

Default Setting

- **auth-port** - 1812
- **timeout** - 5 seconds
- **retransmit** - 2

Command Mode

Global Configuration

Example

```
Console(config)#radius-server 1 host 192.168.1.20 auth-port 181 timeout  
10 retransmit 5 key green  
Console(config)#
```

radius-server acct-port

This command sets the RADIUS server network port for accounting messages. Use the **no** form to restore the default.

Syntax

```
radius-server acct-port port_number  
no radius-server acct-port
```

port_number - RADIUS server UDP port used for accounting messages.
(Range: 1-65535)

Default Setting

1813

Command Mode

Global Configuration

Example

```
Console(config)#radius-server acct-port 181
Console(config)#
```

radius-server auth-port

This command sets the RADIUS server network port for authentication messages. Use the **no** form to restore the default.

Syntax**radius-server auth-port** *port_number***no radius-server auth-port**

port_number - RADIUS server UDP port used for authentication messages. (Range: 1-65535)

Default Setting

181

Command Mode

Global Configuration

Example

```
Console(config)#radius-server port 181
Console(config)#
```

radius-server key

This command sets the RADIUS encryption key. Use the **no** form to restore the default.

Syntax**radius-server key** *key_string***no radius-server key**

key_string - Encryption key used to authenticate logon access for client. Do not use blank spaces in the string. (Maximum length: 20 characters)

Default Setting

None

Command Mode

Global Configuration

Example

```
Console(config)#radius-server key green
Console(config)#
```

radius-server retransmit

This command sets the number of retries. Use the **no** form to restore the default.

Syntax

```
radius-server retransmit number_of_retries  
no radius-server retransmit
```

number_of_retries - Number of times the switch will try to authenticate logon access via the RADIUS server. (Range: 1-30)

Default Setting

2

Command Mode

Global Configuration

Example

```
Console(config)#radius-server retransmit 5  
Console(config)#
```

radius-server timeout

This command sets the interval between transmitting authentication requests to the RADIUS server. Use the **no** form to restore the default.

Syntax

```
radius-server timeout number_of_seconds  
no radius-server timeout
```

number_of_seconds - Number of seconds the switch waits for a reply before resending a request. (Range: 1-65535)

Default Setting

5

Command Mode

Global Configuration

Example

```
Console(config)#radius-server timeout 10  
Console(config)#
```

show radius-server

This command displays the current settings for the RADIUS server.

Default Setting

None

Command Mode

Privileged Exec

Example

```

Console#show radius-server

Remote RADIUS server configuration:

  Global settings
  Communication key with RADIUS server:
  Server port number:                1812
  Retransmit times:                  2
  Request timeout:                    5

Sever 1:
  Server IP address: 192.168.1.1
  Communication key with RADIUS server: *****
  Server port number: 1812
  Retransmit times: 2
  Request timeout: 5

Console#

```

TACACS+ Client

Terminal Access Controller Access Control System (TACACS+) is a logon authentication protocol that uses software running on a central server to control access to TACACS-aware devices on the network. An authentication server contains a database of multiple user name/password pairs with associated privilege levels for each user or group that require management access to a switch.

Table 4-32 TACACS Commands

Command	Function	Mode	Page
tacacs-server host	Specifies the TACACS+ server	GC	4-97
tacacs-server port	Specifies the TACACS+ server network port	GC	4-98
tacacs-server key	Sets the TACACS+ encryption key	GC	4-98
tacacs-server retransmit	Sets the number of retries	GC	4-99
tacacs-server timeout	Sets the interval before resending an authentication request	GC	4-99
show tacacs-server	Shows the current TACACS+ settings	GC	4-100

tacacs-server host

This command specifies the TACACS+ server. Use the **no** form to restore the default.

Syntax

```
[no] tacacs-server index host [host_ip_address] [port port_number]
[timeout timeout] [retransmit retransmit] [key key]
```

- *index* - Specifies the index number of the server. (Range: 1)
- *host_ip_address* - IP address of the server.
- *port_number* - The TACACS+ server TCP port used for authentication messages. (Range: 1-65535)

4 Command Line Interface

- *timeout* - Number of seconds the switch waits for a reply before resending a request. (Range: 1-540 seconds)
- *retransmit* - Number of times the switch will resend an authentication request to the TACACS+ server. (Range: 1-30)
- *key* - Encryption key used to authenticate logon access for client. Do not use blank spaces in the string. (Maximum length: 20 characters)

Default Setting

- **port** - 49
- **timeout** - 5 seconds
- **retransmit** - 2

Command Mode

Global Configuration

Example

```
Console(config)#tacacs-server host 192.168.1.25
Console(config)#
```

tacacs-server port

This command specifies the TACACS+ server network port. Use the **no** form to restore the default.

Syntax

tacacs-server port *port_number*

no tacacs-server port

port_number - TACACS+ server TCP port used for authentication messages. (Range: 1-65535)

Default Setting

49

Command Mode

Global Configuration

Example

```
Console(config)#tacacs-server port 181
Console(config)#
```

tacacs-server key

This command sets the TACACS+ encryption key. Use the **no** form to restore the default.

Syntax

```
tacacs-server key key_string  
no tacacs-server key
```

key_string - Encryption key used to authenticate logon access for the client. Do not use blank spaces in the string.
(Maximum length: 20 characters)

Default Setting

None

Command Mode

Global Configuration

Example

```
Console(config)#tacacs-server key green  
Console(config)#
```

tacacs-server retransmit

This command sets the number of retries. Use the **no** form to restore the default.

Syntax

```
tacacs-server retransmit number_of_retries  
no tacacs-server retransmit
```

number_of_retries - Number of times the switch will try to authenticate logon access via the TACACS+ server. (Range: 1-30)

Default Setting

2

Command Mode

Global Configuration

Example

```
Console(config)#tacacs-server retransmit 5  
Console(config)#
```

tacacs-server timeout

This command sets the interval between transmitting authentication requests to the TACACS+ server. Use the **no** form to restore the default.

Syntax

```
tacacs-server timeout number_of_seconds  
no tacacs-server timeout
```

number_of_seconds - Number of seconds the switch waits for a reply before resending a request. (Range: 1-540)

4 Command Line Interface

Default Setting

5 seconds

Command Mode

Global Configuration

Example

```
Console(config)#tacacs-server timeout 10
Console(config)#
```

show tacacs-server

This command displays the current settings for the TACACS+ server.

Default Setting

None

Command Mode

Privileged Exec

Example

```
Console#show tacacs-server

Remote TACACS+ server configuration:

Global Settings:
Communication Key with TACACS+ Server:
Server Port Number:                49
Retransmit Times :                 2
Request Times :                    5

Server 1:
Server IP address:                  1.2.3.4
Communication key with TACACS+ server: *****
Server port number:                49
Retransmit Times :                 2
Request Times :                    5

Tacacs server group:
Group Name          Member Index
-----
tacacs+            1
Console#
```

AAA Commands

The Authentication, authorization, and accounting (AAA) feature provides the main framework for configuring access control on the switch. The AAA functions require the use of configured RADIUS or TACACS+ servers in the network.

Table 4-33 AAA Commands

Command	Function	Mode	Page
aaa group server	Groups security servers in to defined lists	GC	4-101
server	Configures the IP address of a server in a group list	SG	4-102
aaa accounting dot1x	Enables accounting of 802.1X services	GC	4-102
aaa accounting exec	Enables accounting of Exec services	GC	4-103
aaa accounting commands	Enables accounting of Exec mode commands	GC	4-104
aaa accounting update	Enables periodoc updates to be sent to the accounting server	GC	4-105
accounting dot1x	Applies an accounting method to an interface for 802.1X service requests	IC	4-106
accounting exec	Applies an accounting method to local console, Telnet or SSH connections	Line	4-106
accounting commands	Applies an accounting method to CLI commands entered by a user	Line	4-107
aaa authorization exec	Enables authorization of Exec sessions	GC	4-107
authorization exec	Applies an authorization method to local console, Telnet or SSH connections	Line	4-108
show accounting	Displays all accounting information	PE	4-109

aaa group server

Use this command to name a group of security server hosts. To remove a server group from the configuration list, enter the **no** form of this command.

Syntax

[no] aaa group server {radius | tacacs+} group-name

- **radius** - Defines a RADIUS server group.
- **tacacs+** - Defines a TACACS+ server group.
- **group-name** - A text string that names a security server group.
(Range: 1-7 characters)

Default Setting

None

Command Mode

Global Configuration

Example

```
Console(config)#aaa group server radius tps
Console(config-sg-radius)#
```

server

This command adds a security server to an AAA server group. Use the **no** form to remove the associated server from the group.

Syntax

[no] server {*index* | *ip-address*}

- *index* - Specifies the server index. (Range: RADIUS 1-5, TACACS+ 1)
- *ip-address* - Specifies the host IP address of a server.

Default Setting

None

Command Mode

Server Group Configuration

Command Usage

- When specifying the index for a RADIUS server, that server index must already be defined by the **radius-server host** command (see page 4-94).
- When specifying the index for a TACACS+ server, that server index must already be defined by the **tacacs-server host** command (see page 4-97).

Example

```
Console(config)#aaa group server radius tps
Console(config-sg-radius)#server 10.2.68.120
Console(config-sg-radius)#
```

aaa accounting dot1x

This command enables the accounting of requested 802.1X services for network access. Use the **no** form to disable the accounting service.

Syntax

aaa accounting dot1x {**default** | *method-name*} **start-stop** group {**radius** | **tacacs+** | *server-group*}

no aaa accounting dot1x {**default** | *method-name*}

- **default** - Specifies the default accounting method for service requests.
- *method-name* - Specifies an accounting method for service requests. (Range: 1-255 characters)
- **start-stop** - Records accounting from starting point and stopping point.
- **group** - Specifies the server group to use.

- **radius** - Specifies all RADIUS hosts configure with the **radius-server host** command described on page 4-94.
- **tacacs+** - Specifies all TACACS+ hosts configure with the **tacacs-server host** command described on page 4-97.
- **server-group** - Specifies the name of a server group configured with the **aaa group server** command described on 4-101. (Range: 1-255 characters)

Default Setting

Accounting is not enabled
No servers are specified

Command Mode

Global Configuration

Command Usage

Note that the **default** and *method-name* fields are only used to describe the accounting method(s) configured on the specified RADIUS or TACACS+ servers, and do not actually send any information to the servers about the methods to use.

Example

```
Console(config)#aaa accounting dot1x default start-stop group radius
Console(config)#
```

aaa accounting exec

This command enables the accounting of requested Exec services for network access. Use the **no** form to disable the accounting service.

Syntax

aaa accounting exec {**default** | *method-name*} **start-stop group** {**radius** | **tacacs+** | *server-group*}

no aaa accounting exec {**default** | *method-name*}

- **default** - Specifies the default accounting method for service requests.
- *method-name* - Specifies an accounting method for service requests. (Range: 1-255 characters)
- **start-stop** - Records accounting from starting point and stopping point.
- **group** - Specifies the server group to use.

- **radius** - Specifies all RADIUS hosts configure with the **radius-server host** command described on page 4-94.
- **tacacs+** - Specifies all TACACS+ hosts configure with the **tacacs-server host** command described on page 4-97.
- **server-group** - Specifies the name of a server group configured with the **aaa group server** command described on 4-101. (Range: 1-255 characters)

Default Setting

Accounting is not enabled
No servers are specified

Command Mode

Global Configuration

Command Usage

- This command runs accounting for Exec service requests for the local console and Telnet connections.
- Note that the **default** and *method-name* fields are only used to describe the accounting method(s) configured on the specified RADIUS or TACACS+ servers, and do not actually send any information to the servers about the methods to use.

Example

```
Console(config)#aaa accounting exec default start-stop group tacacs+
Console(config)#
```

aaa accounting commands

This command enables the accounting of Exec mode commands. Use the **no** form to disable the accounting service.

Syntax

aaa accounting commands *level* {**default** | *method-name*} **start-stop group** {**tacacs+** | *server-group*}

no aaa accounting commands *level* {**default** | *method-name*}

- *level* - The privilege level for executing commands. (Range: 0-15)
- **default** - Specifies the default accounting method for service requests.
- *method-name* - Specifies an accounting method for service requests. (Range: 1-255 characters)
- **start-stop** - Records accounting from starting point and stopping point.
- **group** - Specifies the server group to use.

- **tacacs+** - Specifies all TACACS+ hosts configure with the **tacacs-server host** command described on page 4-97.
- **server-group** - Specifies the name of a server group configured with the **aaa group server** command described on 4-101. (Range: 1-255 characters)

Default Setting

Accounting is not enabled
No servers are specified

Command Mode

Global Configuration

Command Usage

- The accounting of Exec mode commands is only supported by TACACS+ servers.
- Note that the **default** and *method-name* fields are only used to describe the accounting method(s) configured on the specified TACACS+ server, and do not actually send any information to the server about the methods to use.

Example

```
Console(config)#aaa accounting commands 15 default start-stop group  
tacacs+  
Console(config)#
```

aaa accounting update

This command enables the sending of periodic updates to the accounting server. Use the **no** form to disable accounting updates.

Syntax

aaa accounting update [*periodic interval*]
no aaa accounting update

interval - Sends an interim accounting record to the server at this interval.
(Range: 1-2147483647 minutes)

Default Setting

1 minute

Command Mode

Global Configuration

Command Usage

- When accounting updates are enabled, the switch issues periodic interim accounting records for all users on the system.
- Using the command without specifying an interim interval enables updates, but does not change the current interval setting.

4 Command Line Interface

Example

```
Console(config)#aaa accounting update periodic 30
Console(config)#
```

accounting dot1x

This command applies an accounting method for 802.1X service requests on an interface. Use the **no** form to disable accounting on the interface.

Syntax

```
accounting dot1x {default | list-name}
no accounting dot1x
```

- **default** - Specifies the default method list created with the **aaa accounting dot1x** command (page 4-102).
- *list-name* - Specifies a method list created with the **aaa accounting dot1x** command.

Default Setting

None

Command Mode

Interface Configuration

Example

```
Console(config)#interface ethernet 1/2
Console(config-if)#accounting dot1x tps
Console(config-if)#
```

accounting exec

This command applies an accounting method to local console or Telnet connections. Use the **no** form to disable accounting on the line.

Syntax

```
accounting exec {default | list-name}
no accounting exec
```

- **default** - Specifies the default method list created with the **aaa accounting exec** command (page 4-103).
- *list-name* - Specifies a method list created with the **aaa accounting exec** command.

Default Setting

None

Command Mode

Line Configuration

Example

```
Console(config)#line console
Console(config-line)#accounting exec tps
Console(config-line)#exit
Console(config)#line vty
Console(config-line)#accounting exec default
Console(config-line)#
```

accounting commands

This command applies an accounting method to entered CLI commands. Use the **no** form to disable accounting for entered commands.

Syntax

accounting commands *level* {**default** | *list-name*}

no accounting commands *level*

- *level* - The privilege level for executing commands. (Range: 0-15)
- **default** - Specifies the default method list created with the **aaa accounting commands** command (page 4-104).
- *list-name* - Specifies a method list created with the **aaa accounting commands** command.

Default Setting

None

Command Mode

Line Configuration

Example

```
Console(config)#line console
Console(config-line)#accounting commands 15 default
Console(config-line)#
```

aaa authorization exec

This command enables the authorization for Exec access. Use the **no** form to disable the authorization service.

Syntax

aaa authorization exec {**default** | *method-name*} **group** {**tacacs+**
| *server-group*}

no aaa authorization exec {**default** | *method-name*}

- **default** - Specifies the default authorization method for Exec access.
- *method-name* - Specifies an authorization method for Exec access. (Range: 1-255 characters)
- **group** - Specifies the server group to use.

4 Command Line Interface

- **tacacs+** - Specifies all TACACS+ hosts configure with the **tacacs-server host** command described on page 4-97.
- **server-group** - Specifies the name of a server group configured with the **aaa group server** command described on 4-101. (Range: 1-255 characters)

Default Setting

Authorization is not enabled
No servers are specified

Command Mode

Global Configuration

Command Usage

- This command performs authorization to determine if a user is allowed to run an Exec shell.
- AAA authentication must be enabled before authorization is enabled.
- If this command is issued without a specified named method, the default method list is applied to all interfaces or lines (where this authorization type applies), except those that have a named method explicitly defined.

Example

```
Console(config)#aaa authorization exec default group tacacs+  
Console(config)#
```

authorization exec

This command applies an authorization method to local console or Telnet connections. Use the **no** form to disable authorization on the line.

Syntax

authorization exec {**default** | *list-name*}
no authorization exec

- **default** - Specifies the default method list created with the **aaa authorization exec** command (page 4-107).
- *list-name* - Specifies a method list created with the **aaa authorization exec** command.

Default Setting

None

Command Mode

Line Configuration

Example

```
Console(config)#line console
Console(config-line)#authorization exec tps
Console(config-line)#exit
Console(config)#line vty
Console(config-line)#authorization exec default
Console(config-line)#
```

show accounting

This command displays the current accounting settings per function and per port.

Syntax

show accounting [**commands** [*level*]] | [[**dot1x** [**statistics** [*username user-name* | **interface** *interface*]] | **exec** [**statistics**] | **statistics** [*username user-name* | *interface*]]

- **commands** - Displays command accounting information.
- *level* - Displays command accounting information for a specifiable command level.
- **dot1x** - Displays dot1x accounting information.
- **exec** - Displays Exec accounting records.
- **statistics** - Displays accounting records.
- *user-name* - Displays accounting records for a specifiable username.
- *interface*
 - ethernet** *unit/port*
 - *unit* - Stack unit. (Range: 1)
 - *port* - Port number. (Range: 1-28)

Default Setting

None

Command Mode

Privileged Exec

Example

```
Console#show accounting
Accounting type: dot1x
  Method list: default
  Group list: radius
  Interface:

  Method list: tps
  Group list: radius
  Interface: eth 1/2

Accounting type: Exec
  Method list: default
  Group list: radius
  Interface: vty

Console#
```

Port Security Commands

These commands can be used to enable port security on a port. When using port security, the switch stops learning new MAC addresses on the specified port when it has reached a configured maximum number. Only incoming traffic with source addresses already stored in the dynamic or static address table for this port will be authorized to access the network. The port will drop any incoming frames with a source MAC address that is unknown or has been previously learned from another port. If a device with an unauthorized MAC address attempts to use the switch port, the intrusion will be detected and the switch can automatically take action by disabling the port and sending a trap message.

Table 4-34 Port Security Commands

Command	Function	Mode	Page
port security	Configures a secure port	IC	4-110
mac-address-table static	Maps a static address to a port in a VLAN	GC	4-190
show mac-address-table	Displays entries in the bridge-forwarding database	PE	4-191

port security

This command enables or configures port security. Use the **no** form without any keywords to disable port security. Use the **no** form with the appropriate keyword to restore the default settings for a response to security violation or for the maximum number of allowed addresses.

Syntax

```
port security [action {shutdown | trap | trap-and-shutdown}
| max-mac-count address-count]
no port security [action | max-mac-count]
```

- **action** - Response to take when port security is violated.
 - **shutdown** - Disable port only.
 - **trap** - Issue SNMP trap message only.
 - **trap-and-shutdown** - Issue SNMP trap message and disable port.
- **max-mac-count**
 - *address-count* - The maximum number of MAC addresses that can be learned on a port. (Range: 0-1024)

Default Setting

- Status: Disabled
- Action: None
- Maximum Addresses: 0

Command Mode

Interface Configuration (Ethernet)

Command Usage

- If you enable port security, the switch stops learning new MAC addresses on the specified port when it has reached a configured maximum number. Only incoming traffic with source addresses already stored in the dynamic or static address table will be accepted.
- First use the **port security max-mac-count** command to set the number of addresses, and then use the port security command to enable security on the port.
- Use the **no port security max-mac-count** command to disable port security and reset the maximum number of addresses to the default.
- You can also manually add secure addresses with the **mac-address-table static** command.
- A secure port has the following restrictions:
 - Cannot use port monitoring.
 - Cannot be a multi-VLAN port.
 - Cannot be connected to a network interconnection device.
 - Cannot be a trunk port.
- If a port is disabled due to a security violation, it must be manually re-enabled using the **no shutdown** command.

Example

The following example enables port security for port 5, and sets the response to a security violation to issue a trap message:

```
Console(config)#interface ethernet 1/5
Console(config-if)#port security action trap
```

Related Commands

- shutdown (4-171)
- mac-address-table static (4-190)
- show mac-address-table (4-191)

802.1X Port Authentication

The switch supports IEEE 802.1X (dot1x) port-based access control that prevents unauthorized access to the network by requiring users to first submit credentials for authentication. Client authentication is controlled centrally by a RADIUS server using EAP (Extensible Authentication Protocol).

Table 4-35 802.1X Port Authentication

Command	Function	Mode	Page
dot1x system-auth-control	Enables dot1x globally on the switch.	GC	4-112
dot1x default	Resets all dot1x parameters to their default values	GC	4-112
dot1x max-req	Sets the maximum number of times that the switch retransmits an EAP request/identity packet to the client before it times out the authentication session	IC	4-113
dot1x port-control	Sets dot1x mode for a port interface	IC	4-113

Table 4-35 802.1X Port Authentication (Continued)

Command	Function	Mode	Page
dot1x operation-mode	Allows single or multiple hosts on an dot1x port	IC	4-114
dot1x re-authenticate	Forces re-authentication on specific ports	PE	4-114
dot1x re-authentication	Enables re-authentication for all ports	IC	4-115
dot1x timeout quiet-period	Sets the time that a switch port waits after the Max Request Count has been exceeded before attempting to acquire a new client	IC	4-115
dot1x timeout re-authperiod	Sets the time period after which a connected client must be re-authenticated	IC	4-116
dot1x timeout tx-period	Sets the time period during an authentication session that the switch waits before re-transmitting an EAP packet	IC	4-116
dot1x intrusion-action	Sets the port response to intrusion when authentication fails	IC	4-117
show dot1x	Shows all dot1x related information	PE	4-117

dot1x system-auth-control

This command enables 802.1X port authentication globally on the switch. Use the **no** form to restore the default.

Syntax

[no] dotx system-auth-control

Default Setting

Disabled

Command Mode

Global Configuration

Example

```
Console(config)#dot1x system-auth-control
Console(config)#
```

dot1x default

This command sets all configurable dot1x global and port settings to their default values.

Command Mode

Global Configuration

Example

```
Console(config)#dot1x default
Console(config)#
```

dot1x max-req

This command sets the maximum number of times the switch port will retransmit an EAP request/identity packet to the client before it times out the authentication session. Use the **no** form to restore the default.

Syntax

```
dot1x max-req count  
no dot1x max-req
```

count – The maximum number of requests (Range: 1-10)

Default

2

Command Mode

Interface Configuration

Example

```
Console(config)#interface eth 1/2  
Console(config-if)#dot1x max-req 2  
Console(config-if)#
```

dot1x port-control

This command sets the dot1x mode on a port interface. Use the **no** form to restore the default.

Syntax

```
dot1x port-control {auto | force-authorized | force-unauthorized}  
no dot1x port-control
```

- **auto** – Requires a dot1x-aware connected client to be authorized by the RADIUS server. Clients that are not dot1x-aware will be denied access.
- **force-authorized** – Configures the port to grant access to all clients, either dot1x-aware or otherwise.
- **force-unauthorized** – Configures the port to deny access to all clients, either dot1x-aware or otherwise.

Default

force-authorized

Command Mode

Interface Configuration

Example

```
Console(config)#interface eth 1/2  
Console(config-if)#dot1x port-control auto  
Console(config-if)#
```

dot1x operation-mode

This command allows single or multiple hosts (clients) to connect to an 802.1X-authorized port. Use the **no** form with no keywords to restore the default to single host. Use the **no** form with the **multi-host max-count** keywords to restore the default maximum count.

Syntax

```
dot1x operation-mode {single-host | multi-host [max-count count]}  
no dot1x operation-mode [multi-host max-count]
```

- **single-host** – Allows only a single host to connect to this port.
- **multi-host** – Allows multiple host to connect to this port.
- **max-count** – Keyword for the maximum number of hosts.
 - *count* – The maximum number of hosts that can connect to a port. (Range: 1-1024; Default: 5)

Default

Single-host

Command Mode

Interface Configuration

Command Usage

- The “max-count” parameter specified by this command is only effective if the dot1x mode is set to “auto” by the dot1x port-control command (page 4-113).
- In “multi-host” mode, only one host connected to a port needs to pass authentication for all other hosts to be granted network access. Similarly, a port can become unauthorized for all hosts if one attached host fails re-authentication or sends an EAPOL logoff message.

Example

```
Console(config)#interface eth 1/2  
Console(config-if)#dot1x operation-mode multi-host max-count 10  
Console(config-if)#
```

dot1x re-authenticate

This command forces re-authentication on all ports or a specific interface.

Syntax

```
dot1x re-authenticate [interface]
```

interface

- **ethernet unit/port**
 - *unit* - Stack unit. (Range: 1)
 - *port* - Port number. (Range: 1-28/52)

Command Mode

Privileged Exec

Example

```
Console#dot1x re-authenticate
Console#
```

dot1x re-authentication

This command enables periodic re-authentication globally for all ports. Use the **no** form to disable re-authentication.

Syntax

[no] dot1x re-authentication

Command Mode

Interface Configuration

Example

```
Console(config)#interface eth 1/2
Console(config-if)#dot1x re-authentication
Console(config-if)#
```

dot1x timeout quiet-period

This command sets the time that a switch port waits after the Max Request Count has been exceeded before attempting to acquire a new client. Use the **no** form to reset the default.

Syntax

dot1x timeout quiet-period *seconds*
no dot1x timeout quiet-period

seconds - The number of seconds. (Range: 1-65535)

Default

60 seconds

Command Mode

Interface Configuration

Example

```
Console(config)#interface eth 1/2
Console(config-if)#dot1x timeout quiet-period 350
Console(config-if)#
```

dot1x timeout re-authperiod

This command sets the time period after which a connected client must be re-authenticated.

Syntax

dot1x timeout re-authperiod *seconds*
no dot1x timeout re-authperiod

seconds - The number of seconds. (Range: 1-65535)

Default

3600 seconds

Command Mode

Interface Configuration

Example

```
Console(config)#interface eth 1/2
Console(config-if)#dot1x timeout re-authperiod 300
Console(config-if)#
```

dot1x timeout tx-period

This command sets the time that an interface on the switch waits during an authentication session before re-transmitting an EAP packet. Use the **no** form to reset to the default value.

Syntax

dot1x timeout tx-period *seconds*
no dot1x timeout tx-period

seconds - The number of seconds. (Range: 1-65535)

Default

30 seconds

Command Mode

Interface Configuration

Example

```
Console(config)#interface eth 1/2
Console(config-if)#dot1x timeout tx-period 300
Console(config-if)#
```

dot1x intrusion-action

This command sets the port's response to a failed authentication, either to block all traffic, or to assign all traffic for the port to a guest VLAN. Use the **no** form to reset the default.

Syntax

```
dot1x intrusion-action {block-traffic | guest-vlan}
no dot1x intrusion-action
```

Default

block-traffic

Command Mode

Interface Configuration

Command Usage

For guest VLAN assignment to be successful, the VLAN must be configured and set as active ("vlan database" on page 4-242) and assigned as the guest VLAN for the port ("network-access guest-vlan" on page 4-124).

Example

```
Console(config)#interface eth 1/2
Console(config-if)#dot1x intrusion-action guest-vlan
Console(config-if)#
```

show dot1x

This command shows general port authentication related settings on the switch or a specific interface.

Syntax

```
show dot1x [statistics] [interface interface]
```

- **statistics** - Displays dot1x status for each port.
- *interface*
 - **ethernet *unit/port***
 - *unit* - Stack unit. (Range: 1)
 - *port* - Port number. (Range: 1-28/52)

Command Mode

Privileged Exec

Command Usage

This command displays the following information:

- *Global 802.1X Parameters* – Shows whether or not 802.1X port authentication is globally enabled on the switch.
- *802.1X Port Summary* – Displays the port access control parameters for each interface, including the following items:

- Status – Administrative state for port access control.
- Operation Mode – Dot1x port control operation mode (page 4-114).
- Mode – Dot1x port control mode (page 4-113).
- Authorized – Authorization status (yes or n/a - not authorized).
- **802.1X Port Details** – Displays the port access control parameters for each interface, including the following items:
 - reauth-enabled – Periodic re-authentication (page 4-115).
 - reauth-period – Time after which a connected client must be re-authenticated (page 4-116).
 - quiet-period – Time a port waits after Max Request Count is exceeded before attempting to acquire a new client (page 4-115).
 - tx-period – Time a port waits during authentication session before re-transmitting EAP packet (page 4-116).
 - supplicant-timeout – Supplicant timeout.
 - server-timeout – Server timeout.
 - reauth-max – Maximum number of reauthentication attempts.
 - max-req – Maximum number of times a port will retransmit an EAP request/identity packet to the client before it times out the authentication session (page 4-113).
 - Status – Authorization status (authorized or not).
 - Operation Mode – Shows if single or multiple hosts (clients) can connect to an 802.1X-authorized port.
 - Max Count – The maximum number of hosts allowed to access this port (page 4-114).
 - Port-control – Shows the dot1x mode on a port as auto, force-authorized, or force-unauthorized (page 4-113).
 - Supplicant – MAC address of authorized client.
 - Current Identifier – The integer (0-255) used by the Authenticator to identify the current authentication session.
 - Intrusion action – Shows whether the switch will block all non-EAP traffic or assign traffic on the port to a guest VLAN if authentication fails.
- **Authenticator State Machine**
 - State – Current state (including initialize, disconnected, connecting, authenticating, authenticated, aborting, held, force_authorized, force_unauthorized).
 - Reauth Count – Number of times connecting state is re-entered.
- **Backend State Machine**
 - State – Current state (including request, response, success, fail, timeout, idle, initialize).
 - Request Count – Number of EAP Request packets sent to the Supplicant without receiving a response.

- Identifier(Server) – Identifier carried in the most recent EAP Success, Failure or Request packet received from the Authentication Server.
- *Reauthentication State Machine*
 - State – Current state (including initialize, reauthenticate).

Example

```

Console#show dot1x
Global 802.1X Parameters
  system-auth-control: enable

802.1X Port Summary

Port Name   Status           Operation Mode   Mode               Authorized
1/1         disabled        Single-Host     ForceAuthorized    n/a
1/2         enabled         Single-Host     auto                yes
:
:
1/28        disabled        Single-Host     ForceAuthorized    n/a

802.1X Port Details

802.1X is disabled on port 1/1

802.1X is enabled on port 1/2
  reauth-enabled: Enable
  reauth-period: 1800
  quiet-period: 30
  tx-period: 40
  supplicant-timeout: 30
  server-timeout: 10
  reauth-max: 2
  max-req: 5
Status           Authorized
Operation mode   Single-Host
Max count        5
Port-control     Auto
Supplicant       00-12-cf-49-5e-dc
Current Identifier 3
Intrusion action Guest VLAN

Authenticator State Machine
State            Authenticated
Reauth Count     0

Backend State Machine
State            Idle
Request Count    0
Identifier(Server) 2

Reauthentication State Machine
State            Initialize
:
:
802.1X is disabled on port 1/28
Console#

```

Network Access – MAC Address Authentication

The Network Access feature controls host access to the network by authenticating its MAC address on the connected switch port. Traffic received from a specific MAC address is forwarded by the switch only if the source MAC address is successfully authenticated by a central RADIUS server. While authentication for a MAC address is in progress, all traffic is blocked until authentication is completed. On successful authentication, the RADIUS server may optionally assign VLAN settings for the switch port.

Table 4-36 Network Access

Command	Function	Mode	Page
network-access mode	Enables MAC authentication on an interface	IC	4-120
network-access max-mac-count	Sets a maximum for authenticated MAC addresses on an interface	IC	4-121
mac-authentication intrusion-action	Determines the port response when a connected host fails MAC authentication.	IC	4-122
mac-authentication max-mac-count	Sets a maximum for mac-authentication authenticated MAC addresses on an interface	IC	4-122
network-access dynamic-qos	Enables dynamic quality of service feature	IC	4-123
network-access dynamic-vlan	Enables dynamic VLAN assignment from a RADIUS server	IC	4-123
network-access guest-vlan	Specifies the guest VLAN	IC	4-124
network-access link-detection	Enables the link detection feature	IC	4-124
network-access link-detection link-down	Configures the link detection feature to detect and act upon link down events	IC	4-124
network-access link-detection link-up	Configures the link detection feature to detect and act upon link up events	IC	4-124
network-access link-detection link-up-down	Configures the link detection feature to detect and act upon both link-up and link-down events	IC	4-124
mac-authentication reauth-time	Sets the time period after which a connected MAC address must be re-authenticated	GC	4-126
clear network-access	Clears authenticated MAC addresses from the address table	PE	4-127
show network-access	Displays the MAC authentication settings for port interfaces	PE	4-127
show network-access mac-address-table	Displays information for entries in the secure MAC address table	PE	4-128

network-access mode

Use this command to enable network access authentication on a port interface. Use the **no** form of this command to disable network access authentication.

Syntax

[no] network-access mode mac-authentication

Default Setting

Disabled

Command Mode

Interface Configuration

Command Usage

- When enabled on a port interface, the authentication process sends a Password Authentication Protocol (PAP) request to a configured RADIUS server. The username and password are both equal to the MAC address being authenticated.
- On the RADIUS server, PAP username and passwords must be configured in the MAC address format XX-XX-XX-XX-XX-XX (all in upper case).
- The RADIUS server may optionally return a VLAN identifier list. VLAN identifier list is carried in the “Tunnel-Private-Group-ID” attribute. The VLAN list can contain multiple VLAN identifiers in the format “1u,2t,” where “u” indicates untagged VLAN and “t” tagged VLAN. The “Tunnel-Type” attribute should be set to “VLAN,” and the “Tunnel-Medium-Type” attribute set to “802.”
- Authenticated MAC addresses are stored as dynamic entries in the switch secure MAC address table and are removed when the aging time expires. The maximum number of secure MAC addresses supported for the switch system is 1024.
- Configured static MAC addresses are added to the secure address table when seen on a switch port. Static addresses are treated as authenticated without sending a request to a RADIUS server.
- MAC authentication, 802.1X, and port security cannot be configured together on the same port. Only one security mechanism can be applied.
- MAC authentication cannot be configured on trunk ports.
- When a port interface status changes to down, all MAC addresses are cleared from the secure MAC address table. Static VLAN assignments are not restored.

Example

```
Console(config-if)#network-access mode mac-authentication
Console(config-if)#
```

network-access max-mac-count

Use this command to set the maximum number of MAC addresses that can be authenticated on a port interface via all forms of authentication. Use the **no** form of this command to restore the default.

Syntax

```
network-access max-mac-count count
no network-access max-mac-count
```

4 Command Line Interface

count - The maximum number of authenticated MAC addresses allowed.
(Range: 1 to 2048; 0 for unlimited)

Default Setting

2048

Command Mode

Interface Configuration

Command Usage

The maximum number of MAC addresses per port is 2048, and the maximum number of secure MAC addresses supported for the switch system is 1024. When the limit is reached, all new MAC addresses are treated as authentication failed.

Example

```
Console(config-if)#network-access max-mac-count 5
Console(config-if)#
```

mac-authentication intrusion-action

Use this command to configure the port response to a host MAC authentication failure. Use the no form of this command to restore the default.

Syntax

mac-authentication intrusion-action [block traffic | pass traffic]
no mac-authentication intrusion-action

Default Setting

Block Traffic

Command Mode

Interface Config

Example

```
Console(config-if)#mac-authentication intrusion-action block-traffic
Console(config-if)#
```

mac-authentication max-mac-count

Use this command to set the maximum number of MAC addresses that can be authenticated on a port via 802.1X authentication or MAC authentication. Use the no form of this command to restore the default.

Syntax

mac-authentication max-mac-count *count*
no mac-authentication max-mac-count

count - The maximum number of 802.1X and MAC-authenticated MAC addresses allowed. (Range: 1-1024)

Default Setting

1024

Command Mode

Interface Config

Example

```
Console(config-if)#mac-authentication max-mac-count 32
Console(config-if)#
```

network-access dynamic-qos

Use this command to enable the dynamic QoS feature for an authenticated port. Use the **no** form to restore the default.

Syntax

[no] **network-access dynamic-qos**

Default Setting

Disabled

Command Mode

Interface Configuration

Example

The following example enables the dynamic QoS feature on port 1.

```
Console(config)#interface ethernet 1/1
Console(config-if)#network-access dynamic-qos
Console(config-if)#
```

network-access dynamic-vlan

Use this command to enable dynamic VLAN assignment for an authenticated port. Use the **no** form to disable dynamic VLAN assignment.

Syntax

[no] **network-access dynamic-vlan**

Default Setting

Enabled

Command Mode

Interface Configuration

Command Usage

- When enabled, the VLAN identifiers returned by the RADIUS server will be applied to the port, providing the VLANs have already been created on the switch. GVRP is not used to create the VLANs.

4 Command Line Interface

- The VLAN settings specified by the first authenticated MAC address are implemented for a port. Other authenticated MAC addresses on the port must have same VLAN configuration, or they are treated as authentication failure.
- If dynamic VLAN assignment is enabled on a port and the RADIUS server returns no VLAN configuration, the authentication is still treated as a success.
- When the dynamic VLAN assignment status is changed on a port, all authenticated addresses are cleared from the secure MAC address table.

Example

The following example enables dynamic VLAN assignment on port 1.

```
Console(config)#interface ethernet 1/1
Console(config-if)#network-access dynamic-vlan
Console(config-if)#
```

network-access guest-vlan

Use this command to assign all traffic on a port to a guest VLAN when network access (MAC authentication) or 802.1x authentication is rejected. Use the **no** form of this command to disable guest VLAN assignment.

Syntax

```
network-access guest-vlan vlan-id
no network-access guest-vlan
```

Default Setting

Disabled

Command Mode

Interface Configuration

Command Usage

- The VLAN to be used as the guest VLAN must be defined and set as active (“vlan database” on page 4-242).
- When used with 802.1x authentication, the intrusion-action configuration must be set for ‘guest-vlan’ to be effective (“dot1x intrusion-action” on page 4-117).

Example

```
Console(config)#interface ethernet 1/1
Console(config-if)#network-access guest-vlan 25
Console(config-if)#
```

network-access link-detection

Use this command to enable the link detection feature. Use the **no** form of this command to restore the default.

Syntax

```
[no] network-access link-detection
```

Default Setting

Disabled

Command Mode

Interface Configuration

Example

```
Console(config)#interface ethernet 1/1
Console(config-if)#network-access link-detection
Console(config-if)#
```

network-access link-detection link-down

Use this command to configure the link detection feature to detect and link down events. When a link down event is detected, the feature can shut down the port, send an SNMP trap, or both. Use the no form of this command to disable this feature.

Syntax

```
network-access link-detection link-down action [shutdown | trap |
trap-and-shutdown]
no network-access link-detection
```

Default Setting

Disabled

Command Mode

Interface Configuration

Example

```
Console(config)#interface ethernet 1/1
Console(config-if)#network-access link-detection link-down action trap
Console(config-if)#
```

network-access link-detection link-up

Use this command to configure the link detection feature to detect link up events. When a link up event is detected, the feature can shut down the port, send an SNMP trap, or both. Use the no form of this command to disable this feature.

Syntax

```
network-access link-detection link-up action [shutdown | trap |
trap-and-shutdown]
no network-access link-detection
```

Default Setting

Disabled

4 Command Line Interface

Command Mode

Interface Configuration

Example

```
Console(config)#interface ethernet 1/1
Console(config-if)#network-access link-detection link-up action trap
Console(config-if)#
```

network-access link-detection link-up-down

Use this command to configure the link detection feature to detect link-up and link-down events. When either a link-up or link-down event is detected, the feature can shut down the port, send an SNMP trap, or both. Use the **no** form of this command to disable this feature.

Syntax

```
network-access link-detection link-up-down action [shutdown | trap |
trap-and-shutdown]
no network-access link-detection
```

Default Setting

Disabled

Command Mode

Interface Configuration

Example

```
Console(config)#interface ethernet 1/1
Console(config-if)#network-access link-detection link-up-down action trap
Console(config-if)#
```

mac-authentication reauth-time

Use this command to set the time period after which a connected MAC address must be re-authenticated. Use the **no** form of this command to restore the default value.

Syntax

```
mac-authentication reauth-time seconds
no mac-authentication reauth-time
```

seconds - The reauthentication time period.
(Range: 120-1000000 seconds)

Default Setting

1800

Command Mode

Global Configuration

Command Usage

- The reauthentication time is a global setting and applies to all ports.
- When the reauthentication time expires for a secure MAC address it is reauthenticated with the RADIUS server. During the reauthentication process traffic through the port remains unaffected.

Example

```
Console(config)#mac-authentication reauth-time 300
Console(config)#
```

clear network-access

Use this command to clear entries from the secure MAC addresses table.

Syntax

clear network-access mac-address-table [**static** | **dynamic**]
[**address** *mac-address*] [**interface** *interface*]

- **static** - Specifies static address entries.
- **dynamic** - Specifies dynamic address entries.
- *mac-address* - Specifies a MAC address entry. (Format: xx-xx-xx-xx-xx-xx)
- *interface* - Specifies a port interface.
 - **ethernet** *unit/port*
 - *unit* - This is unit 1.
 - *port* - Port number. (Range: 1-28/52)

Default Setting

None

Command Mode

Privileged Exec

Example

```
Console#clear network-access mac-address-table interface ethernet 1/1
Console#
```

show network-access

Use this command to display the MAC authentication settings for port interfaces.

Syntax

show network-access [**interface** *interface*]

- *interface* - Specifies a port interface.
- **ethernet** *unit/port*
 - *unit* - This is unit 1.
 - *port* - Port number. (Range: 1-28/52)

4 Command Line Interface

Default Setting

Displays the settings for all interfaces.

Command Mode

Privileged Exec

Example

```
Console#show network-access interface ethernet 1/1
Global secure port information
Reauthentication Time           : 1800
-----
Port : 1/1
MAC Authentication              : Disabled
MAC Authentication Intrusion action : Block traffic
MAC Authentication Maximum MAC Counts : 1024
Maximum MAC Counts             : 2048
Dynamic VLAN Assignment        : Enabled
Guest VLAN                     : Disabled
Console#
```

show network-access mac-address-table

Use this command to display secure MAC address table entries.

Syntax

```
show network-access mac-address-table [static | dynamic]
[address mac-address [mask]] [interface interface] [sort {address |
interface}]
```

- **static** - Specifies static address entries.
- **dynamic** - Specifies dynamic address entries.
- *mac-address* - Specifies a MAC address entry. (Format: xx-xx-xx-xx-xx-xx)
- *mask* - Specifies a MAC address bit mask for filtering displayed addresses.
- *interface* - Specifies a port interface.
 - **ethernet** *unit/port*
 - *unit* - This is unit 1.
 - *port* - Port number. (Range: 1-28/52)
- **sort** - Sorts displayed entries by either MAC address or interface.

Default Setting

Displays all filters.

Command Mode

Privileged Exec

Command Usage

When using a bit mask to filter displayed MAC addresses, a 1 means "care" and a 0 means "don't care". For example, a MAC of 00-00-01-02-03-04 and mask FF-FF-FF-00-00-00 would result in all MACs in the range 00-00-01-00-00-00 to 00-00-01-FF-FF-FF to be displayed. All other MACs would be filtered out.

Example

```

Console#show network-access mac-address-table
-----
Port  MAC-Address          RADIUS-Server  Attribute  Time
-----
1/1   00-00-01-02-03-04    172.155.120.17 Static     00d06h32m50s
1/1   00-00-01-02-03-05    172.155.120.17 Dynamic    00d06h33m20s
1/1   00-00-01-02-03-06    172.155.120.17 Static     00d06h35m10s
1/3   00-00-01-02-03-07    172.155.120.17 Dynamic    00d06h34m20s
Console#

```

Web Authentication

Web authentication allows stations to authenticate and access the network in situations where 802.1X or Network Access authentication are infeasible or impractical. The web authentication feature allows unauthenticated hosts to request and receive a DHCP assigned IP address and perform DNS queries. All other traffic, except for http protocol traffic, is blocked. The switch intercepts http protocol traffic and redirects it to a switch-generated webpage that facilitates username and password authentication via RADIUS. Once authentication is successful, the web browser is forwarded on to the originally requested web page. Successful authentication is valid for all hosts connected to the port.

- Notes:**
1. MAC authentication, web authentication, 802.1X, and port security cannot be configured together on the same port. Only one security mechanism can be applied.
 2. RADIUS authentication must be activated and configured properly for the web authentication feature to work properly. (See "Configuring Local/Remote Logon Authentication" on page 3-48)
 3. Web authentication cannot be configured on trunk ports.

Table 4-37 Web Authentication

Command	Function	Mode	Page
web-auth login-attempts	Defines the limit for failed web authentication login attempts	GC	4-130
web-auth login-fail-page-url	Defines the external URL to which a host is directed after a failed web authentication attempt	GC	4-130
web-auth login-page-url	Defines the external URL to which a host is directed to complete web authentication	GC	4-131
web-auth login-success-page-url	Defines the external URL to which a host is directed after a successful web authentication	GC	4-131

Table 4-37 Web Authentication (Continued)

Command	Function	Mode	Page
web-auth quiet-period	Defines the amount of time to wait after the limit for failed login attempts is exceeded.	GC	4-132
web-auth session-timeout	Defines the amount of time a session remains valid	GC	4-132
web-auth system-auth-control	Enables web authentication globally for the switch	GC	4-133
web-auth	Enables web authentication for an interface	IC	4-133
show web-auth	Displays global web authentication parameters	PE	4-134
show web-auth interface	Displays interface-specific web authentication parameters and statistics	PE	4-134
web-auth re-authenticate (Port)	Ends all web authentication sessions on the port and forces the users to re-authenticate	PE	4-135
web-auth re-authenticate (IP)	Ends the web authentication session associated with the designated IP and forces the user to re-authenticate	PE	4-135
show web-auth summary	Displays a summary of web authentication port parameters and statistics	PE	4-135

web-auth login-attempts

This command defines the limit for failed web authentication login attempts. After the limit is reached, the switch refuses further login attempts until the quiet time expires. Use the **no** form to restore the default.

Syntax

```
web-auth login-attempts count
no web-auth login-attempts
```

count - The limit of allowed failed login attempts. (Range: 1-3)

Default Setting

3 login attempts

Command Mode

Global Configuration

Example

```
Console(config)#web-auth login-attempts 2
Console(config)#
```

web-auth login-fail-page-url

This command defines the external URL to which a host is directed after a failed web authentication attempt. Use the **no** form to restore the default.

Syntax

```
web-auth login-fail-page-url fail-url
no web-auth login-fail-page-url
```

fail-url - The URL to which a host is directed after a failed web authentication attempt.

Default Setting

None

Command Mode

Global Configuration

Command Usage

This command is not supported in the current release of the firmware.

Example

```
Console(config)#web-auth login-fail-page-url http://www.example.com/fail/
Console(config)#
```

web-auth login-page-url

This command defines the external authentication page URL to which a host is directed to complete web authentication. Use the **no** form to restore the default.

Syntax

```
web-auth login-page-url login-url
no web-auth login-page-url
```

login-url - The URL to which a host is forwarded to complete web authentication.

Default Setting

Switch-generated login page

Command Mode

Global Configuration

Command Usage

This command is not supported in the current release of the firmware.

Example

```
Console(config)#web-auth login-page-url http://www.example.com/login/
Console(config)#
```

web-auth login-success-page-url

This command defines the external URL to which a host is directed after a successful web authentication attempt. Use the **no** form to restore the default.

Syntax

```
web-auth login-success-page-url success-url
no web-auth login-success-page-url
```

4 Command Line Interface

success-url - The URL to which a host is directed after a successful web authentication login.

Default Setting

None

Command Mode

Global Configuration

Command Usage

This command is not supported in the current release of the firmware.

Example

```
Console(config)#web-auth login-success-page-url http://www.example.com/
  success/
Console(config)#
```

web-auth quiet-period

This command defines the amount of time a host must wait after exceeding the failed login attempts limit, before it may attempt web authentication again. Use the **no** form to restore the default.

Syntax

web-auth quiet-period *time*
no web-auth quiet period

time - The amount of time the host must wait before attempting authentication again. (Range: 1-180 seconds)

Default Setting

60 seconds

Command Mode

Global Configuration

Example

```
Console(config)#web-auth quiet-period 120
Console(config)#
```

web-auth session-timeout

This command defines the amount of time a web-authentication session remains valid. When the session-timeout time has been reached, the host is logged off and must re-authenticate itself the next time data transmission takes place. Use the **no** form to restore the default.

Syntax

web-auth session-timeout *timeout*
no web-auth session timeout

timeout - The amount of time that an authenticated session remains valid.
(Range: 300-3600 seconds)

Default Setting

3600 seconds

Command Mode

Global Configuration

Example

```
Console(config)#web-auth session-timeout 1800
Console(config)#
```

web-auth system-auth-control

This command globally enables web authentication for the switch. Use the no form to restore the default.

Syntax

[no] web-auth system-auth-control

Default Setting

Disabled

Command Mode

Global Configuration

Command Usage

Both **web-auth system-auth-control** for the switch and **web-auth** for an interface must be enabled for the web authentication feature to be active.

Example

```
Console(config)#web-auth system-auth-control
Console(config)#
```

web-auth

This command enables web authentication for an interface. Use the no form to restore the default.

Syntax

[no] web-auth

Default Setting

Disabled

Command Mode

Interface Configuration

4 Command Line Interface

Command Usage

Both **web-auth system-auth-control** for the switch and **web-auth** for an interface must be enabled for the web authentication feature to be active.

Example

```
Console(config-if)#web-auth
Console(config-if)#
```

show web-auth

This command displays global web authentication parameters.

Syntax

show web-auth

Default Setting

None

Command Mode

Privileged Exec

Example

```
Console#sh web-auth

Global Web-Auth Parameters

  System Auth Control      : Enabled
  Login Page URL          :
  Login Fail Page URL     :
  Login Success Page URL  :
  Session Timeout         : 3600
  Quiet Period            : 60
  Max Login Attempts      : 3
Console#
```

show web-auth interface

This command displays interface-specific web authentication parameters and statistics.

Syntax

show web-auth interface *interface*

- *interface* - Specifies a port interface.
- **ethernet** *unit/port*
 - *unit* - This is unit 1.
 - *port* - Port number. (Range: 1-28/52)

Default Setting

None

Command Mode

Privileged Exec

Example

```
Console#show web-auth interface eth 1/2
Web Auth Status      : Enabled

Host Summary

IP address           Web-Auth-State Remaining-Session-Time
-----
Console#
```

web-auth re-authenticate (Port)

This command ends all web authentication sessions connected to the port and forces the users to re-authenticate.

Syntax

web-auth re-authenticate interface *interface*

- *interface* - Specifies a port interface.
 - **ethernet** *unit/port*
 - *unit* - This is unit 1.
 - *port* - Port number. (Range: 1-28/52)

Default Setting

None

Command Mode

Privileged Exec

Example

```
Console#web-auth re-authenticate interface ethernet 1/2
Failed to reauth .
Console#
```

web-auth re-authenticate (IP)

This command ends the web authentication session associated with the designated IP address and forces the user to re-authenticate.

Syntax

web-auth re-authenticate interface *interface ip*

- *interface* - Specifies a port interface.
 - **ethernet** *unit/port*
 - *unit* - This is unit 1.
 - *port* - Port number. (Range: 1-28/52)
- *ip* - IPv4 formatted IP address

4 Command Line Interface

Default Setting

None

Command Mode

Privileged Exec

Example

```
Console#web-auth re-authenticate interface ethernet 1/2 192.168.1.5
Failed to reauth port.
Console#
```

show web-auth summary

This command displays a summary of web authentication port parameters and statistics.

Syntax

show web-auth summary

Default Setting

None

Command Mode

Privileged Exec

Example

```
Console#show web-auth summary

Global Web-Auth Parameters

  System Auth Control      : Enabled
Port      Status          Authenticated Host Count
-----
1/ 1      Disabled            0
1/ 2      Enabled             0
1/ 3      Disabled            0
1/ 4      Disabled            0
1/ 5      Disabled            0
1/ 6      Disabled            0
1/ 7      Disabled            0
1/ 8      Disabled            0
1/ 9      Disabled            0
1/10      Disabled            0
1/11      Disabled            0
1/12      Disabled            0
1/13      Disabled            0
1/14      Disabled            0
1/15      Disabled            0
1/16      Disabled            0
1/17      Disabled            0
1/18      Disabled            0
1/19      Disabled            0
1/20      Disabled            0
1/21      Disabled            0
1/22      Disabled            0
1/23      Disabled            0
1/24      Disabled            0
1/25      Disabled            0
1/26      Disabled            0
1/27      Disabled            0
1/28      Disabled            0
Console#
```

Access Control List Commands

Access Control Lists (ACL) provide packet filtering for IP frames (based on address, protocol, or Layer 4 protocol port number) or any frames (based on MAC address or Ethernet type). To filter packets, first create an access list, add the required rules and then bind the list to a specific port.

Access Control Lists

An ACL is a sequential list of permit or deny conditions that apply to IP addresses, MAC addresses, or other more specific criteria. This switch tests ingress or egress packets against the conditions in an ACL one by one. A packet will be accepted as soon as it matches a permit rule, or dropped as soon as it matches a deny rule. If no rules match for a list of all permit rules, the packet is dropped; and if no rules match for a list of all deny rules, the packet is accepted.

There are three filtering modes:

- Standard IP ACL mode (STD-ACL) filters packets based on the source IP address.
- Extended IP ACL mode (EXT-ACL) filters packets based on source or destination IP address, as well as protocol type and protocol port number.

The following restrictions apply to ACLs:

- Each ACL can have up to 100 rules.
- However, due to resource restrictions, the average number of rules bound the ports should not exceed 20.
- This switch supports ACLs for ingress filtering only. You can only bind one IP ACL to any port for ingress filtering. In other words, only one ACL can be bound to an interface - Ingress IP ACL.

The order in which active ACLs are checked is as follows:

1. User-defined rules in the Ingress IP ACL for ingress ports.
2. Explicit default rule (permit any any) in the ingress IP ACL for ingress ports.
3. If no explicit rule is matched, the implicit default is permit all.

Table 4-38 Access Control Lists

Command Groups	Function	Page
IP ACLs	Configures ACLs based on IP addresses, TCP/UDP port number, and protocol type	4-139
MAC ACLs	Configures ACLs based on hardware addresses, packet format, and Ethernet type	4-143
ACL Information	Displays ACLs and associated rules; shows ACLs assigned to each port	4-148

IP ACLs

Table 4-39 IP ACLs

Command	Function	Mode	Page
access-list ip	Creates an IP ACL and enters configuration mode	GC	4-139
permit, deny	Filters packets matching a specified source IP address	STD-ACL	4-140
permit, deny	Filters packets meeting the specified criteria, including source and destination IP address, TCP/UDP port number, and protocol type	EXT-ACL	4-140
show ip access-list	Displays the rules for configured IP ACLs	PE	4-142
ip access-group	Adds a port to an IP ACL	IC	4-142
show ip access-group	Shows port assignments for IP ACLs	PE	4-142

access-list ip

This command adds an IP access list and enters configuration mode for standard or extended IP ACLs. Use the **no** form to remove the specified ACL.

Syntax

[no] **access-list ip** {**standard** | **extended**} *acl_name*

- **standard** – Specifies an ACL that filters packets based on the source IP address.
- **extended** – Specifies an ACL that filters packets based on the source or destination IP address, and other more specific criteria.
- *acl_name* – Name of the ACL. (Maximum length: 16 characters, no spaces)

Default Setting

None

Command Mode

Global Configuration

Command Usage

- When you create a new ACL or enter configuration mode for an existing ACL, use the **permit** or **deny** command to add new rules to the bottom of the list. To create an ACL, you must add at least one rule to the list.
- To remove a rule, use the **no permit** or **no deny** command followed by the exact text of a previously configured rule.
- An ACL can contain up to 100 rules.

Example

```
Console(config)#access-list ip standard david
Console(config-std-acl)#
```

Related Commands

permit, deny 4-140
ip access-group (4-142)
show ip access-list (4-142)

permit, deny (Standard ACL)

This command adds a rule to a Standard IP ACL. The rule sets a filter condition for packets emanating from the specified source. Use the **no** form to remove a rule.

Syntax

[no] {permit | deny} {any | source bitmask | host source}

- **any** – Any source IP address.
- **source** – Source IP address.
- **bitmask** – Decimal number representing the address bits to match.
- **host** – Keyword followed by a specific IP address.

Default Setting

None

Command Mode

Standard ACL

Command Usage

- New rules are appended to the end of the list.
- Address bitmasks are similar to a subnet mask, containing four integers from 0 to 255, each separated by a period. The binary mask uses 1 bits to indicate “match” and 0 bits to indicate “ignore.” The bitmask is bitwise ANDed with the specified source IP address, and then compared with the address for each IP packet entering the port(s) to which this ACL has been assigned.

Example

This example configures one permit rule for the specific address 10.1.1.21 and another rule for the address range 168.92.16.x – 168.92.31.x using a bitmask.

```
Console(config-std-acl)#permit host 10.1.1.21
Console(config-std-acl)#permit 168.92.16.0 255.255.240.0
```

Related Commands

access-list ip (4-139)

permit, deny (Extended ACL)

This command adds a rule to an Extended IP ACL. The rule sets a filter condition for packets with specific source or destination IP addresses, protocol types, or source or destination protocol ports. Use the **no** form to remove a rule.

Syntax

```
[no] {permit | deny} [protocol-number | udp]
    {any | source address-bitmask | host source}
    {any | destination address-bitmask | host destination}
    [source-port sport [end]] [destination-port dport [end]]
```

```
[no] {permit | deny} tcp
    {any | source address-bitmask | host source}
    {any | destination address-bitmask | host destination}
    [source-port sport [end]] [destination-port dport [end]]
```

- *protocol-number* – A specific protocol number. (Range: 0-255)
- *source* – Source IP address.
- *destination* – Destination IP address.
- *address-bitmask* – Decimal number representing the address bits to match.
- **host** – Keyword followed by a specific IP address.
- *sport* – Protocol¹⁷ source port number. (Range: 0-65535)
- *dport* – Protocol¹⁷ destination port number. (Range: 0-65535)
- *end* – Upper bound of the protocol port range. (Range: 0-65535)

Default Setting

None

Command Mode

Extended ACL

Command Usage

- All new rules are appended to the end of the list.
- Address bitmasks are similar to a subnet mask, containing four integers from 0 to 255, each separated by a period. The binary mask uses 1 bits to indicate “match” and 0 bits to indicate “ignore.” The bitmask is bitwise ANDed with the specified source IP address, and then compared with the address for each IP packet entering the port(s) to which this ACL has been assigned.

Example

This example accepts any incoming packets if the source address is within subnet 10.7.1.x. For example, if the rule is matched; i.e., the rule (10.7.1.0 & 255.255.255.0) equals the masked address (10.7.1.2 & 255.255.255.0), the packet passes through.

```
Console(config-ext-acl)#permit 10.7.1.1 255.255.255.0 any
Console(config-ext-acl)#
```

17. Includes TCP, UDP or other protocol types.

4 Command Line Interface

This allows TCP packets from class C addresses 192.168.1.0 to any destination address when set for destination TCP port 80 (i.e., HTTP).

```
Console(config-ext-acl)#permit 192.168.1.0 255.255.255.0 any
destination-port 80
Console(config-ext-acl)#
```

Related Commands

access-list ip (4-139)

show ip access-list

This command displays the rules for configured IP ACLs.

Syntax

```
show ip access-list {standard | extended} [acl_name]
```

- **standard** – Specifies a standard IP ACL.
- **extended** – Specifies an extended IP ACL.
- **acl_name** – Name of the ACL. (Maximum length: 16 characters, no spaces)

Command Mode

Privileged Exec

Example

```
Console#show ip access-list standard
IP standard access-list david:
  permit host 10.1.1.21
  permit 168.92.0.0 255.255.255.0
Console#
```

Related Commands

permit, deny 4-140
ip access-group (4-142)

ip access-group

This command binds a port to an IP ACL. Use the **no** form to remove the port.

Syntax

```
[no] ip access-group acl_name in
```

- **acl_name** – Name of the ACL. (Maximum length: 16 characters, no spaces)
- **in** – Indicates that this list applies to ingress packets.

Default Setting

None

Command Mode

Interface Configuration (Ethernet)

Command Usage

- A port can only be bound to one ACL.
- If a port is already bound to an ACL and you bind it to a different ACL, the switch will replace the old binding with the new one.
- You must configure a mask for an ACL rule before you can bind it to a port.

Example

```
Console(config)#int eth 1/25
Console(config-if)#ip access-group david in
Console(config-if)#
```

Related Commands

show ip access-list (4-142)

show ip access-group

This command shows the ports assigned to IP ACLs.

Command Mode

Privileged Exec

Example

```
Console#show ip access-group
Interface ethernet 1/25
  IP access-list david in
Console#
```

Related Commands

ip access-group (4-142)

MAC ACLs

The commands in this section configure ACLs based on hardware addresses, packet format, and Ethernet type. To configure MAC ACLs, first create an access list containing the required permit or deny rules, and then bind the access list to one or more ports

Table 4-40 MAC ACL Commands

Command	Function	Mode	Page
access-list mac	Creates a MAC ACL and enters configuration mode	GC	4-144
permit, deny	Filters packets matching a specified source and destination address, packet format, and Ethernet type	MAC-ACL	4-145
show mac access-list	Displays the rules for configured MAC ACLs	PE	4-146

Table 4-40 MAC ACL Commands

Command	Function	Mode	Page
mac access-group	Adds a port to a MAC ACL	IC	4-147
show mac access-group	Shows port assignments for MAC ACLs	PE	4-147

access-list mac

This command adds a MAC access list and enters MAC ACL configuration mode. Use the **no** form to remove the specified ACL.

Syntax

[no] access-list mac *acl_name*

acl_name – Name of the ACL. (Maximum length: 16 characters)

Default Setting

None

Command Mode

Global Configuration

Command Usage

- When you create a new ACL or enter configuration mode for an existing ACL, use the **permit** or **deny** command to add new rules to the bottom of the list. To create an ACL, you must add at least one rule to the list.
- To remove a rule, use the **no permit** or **no deny** command followed by the exact text of a previously configured rule.
- An ACL can contain up to 32 rules.

Example

```
Console(config)#access-list mac jerry
Console(config-mac-acl)#
```

Related Commands

permit, deny (4-145)
mac access-group (4-147)
show mac access-list (4-146)

permit, deny (MAC ACL)

This command adds a rule to a MAC ACL. The rule filters packets matching a specified MAC source or destination address (i.e., physical layer address), or Ethernet protocol type. Use the **no** form to remove a rule.

Syntax

```
[no] {permit | deny}
      {any | host source | source address-bitmask}
      {any | host destination | destination address-bitmask}
      [vid vid vid-bitmask] [ethertype protocol [protocol-bitmask]]
```

Note:- The default is for Ethernet II packets.

```
[no] {permit | deny} tagged-eth2
      {any | host source | source address-bitmask}
      {any | host destination | destination address-bitmask}
      [vid vid vid-bitmask] [ethertype protocol [protocol-bitmask]]
```

```
[no] {permit | deny} untagged-eth2
      {any | host source | source address-bitmask}
      {any | host destination | destination address-bitmask}
      [ethertype protocol [protocol-bitmask]]
```

```
[no] {permit | deny} tagged-802.3
      {any | host source | source address-bitmask}
      {any | host destination | destination address-bitmask}
      [vid vid vid-bitmask]
```

```
[no] {permit | deny} untagged-802.3
      {any | host source | source address-bitmask}
      {any | host destination | destination address-bitmask}
```

- **tagged-eth2** – Tagged Ethernet II packets.
- **untagged-eth2** – Untagged Ethernet II packets.
- **tagged-802.3** – Tagged Ethernet 802.3 packets.
- **untagged-802.3** – Untagged Ethernet 802.3 packets.
- **any** – Any MAC source or destination address.
- **host** – A specific MAC address.
- **source** – Source MAC address.
- **destination** – Destination MAC address range with bitmask.
- **address-bitmask¹⁸** – Bitmask for MAC address (in hexadecimal format).
- **vid** – VLAN ID. (Range: 1-4094)
- **vid-bitmask** – VLAN bitmask. (Range: 1-4095)
- **protocol** – A specific Ethernet protocol number. (Range: 600-fff hex.)
- **protocol-bitmask** – Protocol bitmask. (Range: 600-fff hex.)

18. For all bitmasks, “1” means care and “0” means ignore.

4 Command Line Interface

Default Setting

None

Command Mode

MAC ACL

Command Usage

- New rules are added to the end of the list.
- The **ethertype** option can only be used to filter Ethernet II formatted packets.
- A detailed listing of Ethernet protocol types can be found in RFC 1060. A few of the more common types include the following:
 - 0800 - IP
 - 0806 - ARP
 - 8137 - IPX

Example

This rule permits packets from any source MAC address to the destination address 00-e0-29-94-34-de where the Ethernet type is 0800.

```
Console(config-mac-acl)#permit any host 00-e0-29-94-34-de ethertype 0800
Console(config-mac-acl)#
```

Related Commands

access-list mac (4-144)

show mac access-list

This command displays the rules for configured MAC ACLs.

Syntax

show mac access-list [*acl_name*]

acl_name – Name of the ACL. (Maximum length: 16 characters)

Command Mode

Privileged Exec

Example

```
Console#show mac access-list
MAC access-list jerry:
  permit any 00-e0-29-94-34-de ethertype 0800
Console#
```

Related Commands

permit, deny 4-145
mac access-group (4-147)

mac access-group

This command binds a port to a MAC ACL. Use the **no** form to remove the port.

Syntax

mac access-group *acl_name* **in**

- *acl_name* – Name of the ACL. (Maximum length: 16 characters)
- **in** – Indicates that this list applies to ingress packets.

Default Setting

None

Command Mode

Interface Configuration (Ethernet)

Command Usage

- A port can only be bound to one ACL.
- If a port is already bound to an ACL and you bind it to a different ACL, the switch will replace the old binding with the new one.

Example

```
Console(config)#interface ethernet 1/2
Console(config-if)#mac access-group jerry in
Console(config-if)#
```

Related Commands

show mac access-list (4-146)

show mac access-group

This command shows the ports assigned to MAC ACLs.

Command Mode

Privileged Exec

Example

```
Console#show mac access-group
Interface ethernet 1/5
  MAC access-list M5 in
Console#
```

Related Commands

mac access-group (4-147)

ACL Information

Table 4-41 ACL Information

Command	Function	Mode	Page
show access-list	Show all ACLs and associated rules	PE	4-148
show access-group	Shows the ACLs assigned to each port	PE	4-148

show access-list

This command shows all ACLs and associated rules, as well as all the user-defined masks.

Command Mode

Privileged Exec

Command Usage

Once the ACL is bound to an interface (i.e., the ACL is active), the order in which the rules are displayed is determined by the associated mask.

Example

```
Console#show access-list
IP standard access-list david:
  permit host 10.1.1.21
  permit 168.92.16.0 255.255.240.0
IP extended access-list bob:
  permit 10.7.1.1 255.255.255.0 any
  permit 192.168.1.0 255.255.255.0 any destination-port 80 80
IP access-list jerry:
  permit any host 00-30-29-94-34-de ethertype 800 800
IP extended access-list A6:
  permit any any
Console#
```

show access-group

This command shows the port assignments of ACLs.

Command Mode

Privileged Executive

Example

```
Console#show access-group
Interface ethernet 1/1
  IP access-list jerry in
:
:
Interface ethernet 1/28
  IP access-list jerry in
Console#
```

SNMP Commands

Controls access to this switch from management stations using the Simple Network Management Protocol (SNMP), as well as the error types sent to trap managers.

SNMP Version 3 also provides security features that cover message integrity, authentication, and encryption; as well as controlling user access to specific areas of the MIB tree. To use SNMPv3, first set an SNMP engine ID (or accept the default), specify read and write access views for the MIB tree, configure SNMP user groups with the required security model (i.e., SNMP v1, v2c or v3) and security level (i.e., authentication and privacy), and then assign SNMP users to these groups, along with their specific authentication and privacy passwords.

Table 4-42 SNMP Commands

Command	Function	Mode	Page
snmp-server	Enables the SNMP agent	GC	4-150
show snmp	Displays the status of SNMP communications	NE, PE	4-150
snmp-server community	Sets up the community access string to permit access to SNMP commands	GC	4-151
snmp-server contact	Sets the system contact string	GC	4-152
snmp-server location	Sets the system location string	GC	4-152
snmp-server host	Specifies the recipient of an SNMP notification operation	GC	4-153
snmp-server enable traps	Enables the device to send SNMP traps (i.e., SNMP notifications)	GC	4-155
snmp-server engine-id	Sets the SNMP engine ID	GC	4-156
show snmp engine-id	Shows the SNMP engine ID	PE	4-157
snmp-server view	Adds an SNMP view	GC	4-158
show snmp view	Shows the SNMP views	PE	4-159
snmp-server group	Adds an SNMP group, mapping users to views	GC	4-159
show snmp group	Shows the SNMP groups	PE	4-160
snmp-server user	Adds a user to an SNMP group	GC	4-162
show snmp user	Shows the SNMP users	PE	4-164

snmp-server

This command enables the SNMPv3 engine and services for all management clients (i.e., versions 1, 2c, 3). Use the **no** form to disable the server.

Syntax

[no] snmp-server

Default Setting

Enabled

Command Mode

Global Configuration

Example

```
Console(config)#snmp-server  
Console(config)#
```

show snmp

This command can be used to check the status of SNMP communications.

Default Setting

None

Command Mode

Normal Exec, Privileged Exec

Command Usage

This command provides information on the community access strings, counter information for SNMP input and output protocol data units, and whether or not SNMP logging has been enabled with the **snmp-server enable traps** command.

Example

```
Console#show snmp

SNMP Agent: enabled

SNMP traps:
  Authentication: enable
  Link-up-down: enable

SNMP communities:
  1. private, and the privilege is read-write
  2. public, and the privilege is read-only

0 SNMP packets input
  0 Bad SNMP version errors
  0 Unknown community name
  0 Illegal operation for community name supplied
  0 Encoding errors
  0 Number of requested variables
  0 Number of altered variables
  0 Get-request PDUs
  0 Get-next PDUs
  0 Set-request PDUs
0 SNMP packets output
  0 Too big errors
  0 No such name errors
  0 Bad values errors
  0 General errors
  0 Response PDUs
  0 Trap PDUs

SNMP logging: disabled
Console#
```

snmp-server community

This command defines the SNMP v1 and v2c community access string. Use the **no** form to remove the specified community string.

Syntax

```
snmp-server community string [ro|rw]
no snmp-server community string
```

- **string** - Community string that acts like a password and permits access to the SNMP protocol. (Maximum length: 32 characters, case sensitive; Maximum number of strings: 5)
- **ro** - Specifies read-only access. Authorized management stations are only able to retrieve MIB objects.
- **rw** - Specifies read/write access. Authorized management stations are able to both retrieve and modify MIB objects.

Default Setting

- **public** - Read-only access. Authorized management stations are only able to retrieve MIB objects.

4 Command Line Interface

- private - Read/write access. Authorized management stations are able to both retrieve and modify MIB objects.

Command Mode

Global Configuration

Example

```
Console(config)#snmp-server community alpha rw
Console(config)#
```

snmp-server contact

This command sets the system contact string. Use the **no** form to remove the system contact information.

Syntax

snmp-server contact *string*

no snmp-server contact

string - String that describes the system contact information.
(Maximum length: 255 characters)

Default Setting

None

Command Mode

Global Configuration

Example

```
Console(config)#snmp-server contact Paul
Console(config)#
```

Related Commands

snmp-server location (4-152)

snmp-server location

This command sets the system location string. Use the **no** form to remove the location string.

Syntax

snmp-server location *text*

no snmp-server location

text - String that describes the system location.
(Maximum length: 255 characters)

Default Setting

None

Command Mode

Global Configuration

Example

```
Console(config)#snmp-server location WC-19
Console(config)#
```

Related Commands

snmp-server contact (4-152)

snmp-server host

This command specifies the recipient of a Simple Network Management Protocol notification operation. Use the **no** form to remove the specified host.

Syntax

```
snmp-server host host-addr [inform [retry retries | timeout seconds]]
  community-string [version {1 | 2c | 3 [auth | noauth | priv] [udp-port port]}]
no snmp-server host host-addr
```

- *host-addr* - Internet address of the host (the targeted recipient). (Maximum host addresses: 5 trap destination IP address entries)
- **inform** - Notifications are sent as inform messages. Note that this option is only available for version 2c and 3 hosts. (Default: traps are used)
 - *retries* - The maximum number of times to resend an inform message if the recipient does not acknowledge receipt. (Range: 0-255; Default: 3)
 - *seconds* - The number of seconds to wait for an acknowledgment before resending an inform message. (Range: 0-2147483647 centiseconds; Default: 1500 centiseconds)
- *community-string* - Password-like community string sent with the notification operation to SNMP V1 and V2c hosts. Although you can set this string using the **snmp-server host** command by itself, we recommend that you define this string using the **snmp-server community** command prior to using the **snmp-server host** command. (Maximum length: 32 characters)
- **version** - Specifies whether to send notifications as SNMP Version 1, 2c or 3 traps. (Range: 1, 2c, 3; Default: 1)
 - **auth** | **noauth** | **priv** - This group uses SNMPv3 with authentication, no authentication, or with authentication and privacy. See “Simple Network Management Protocol” on page 3-38 for further information about these authentication and encryption options.
- *port* - Host UDP port to use. (Range: 1-65535; Default: 162)

Default Setting

- Host Address: None
- Notification Type: Traps

- SNMP Version: 1
- UDP Port: 162

Command Mode

Global Configuration

Command Usage

- If you do not enter an **snmp-server host** command, no notifications are sent. In order to configure the switch to send SNMP notifications, you must enter at least one **snmp-server host** command. In order to enable multiple hosts, you must issue a separate **snmp-server host** command for each host.
- The **snmp-server host** command is used in conjunction with the **snmp-server enable traps** command. Use the **snmp-server enable traps** command to enable the sending of traps or informs and to specify which SNMP notifications are sent globally. For a host to receive notifications, at least one **snmp-server enable traps** command and the **snmp-server host** command for that host must be enabled.
- Some notification types cannot be controlled with the **snmp-server enable traps** command. For example, some notification types are always enabled.
- Notifications are issued by the switch as trap messages by default. The recipient of a trap message does not send a response to the switch. Traps are therefore not as reliable as inform messages, which include a request for acknowledgement of receipt. Informs can be used to ensure that critical information is received by the host. However, note that informs consume more system resources because they must be kept in memory until a response is received. Informs also add to network traffic. You should consider these effects when deciding whether to issue notifications as traps or informs.

To send an inform to a SNMPv2c host, complete these steps:

1. Enable the SNMP agent (page 4-150).
2. Allow the switch to send SNMP traps; i.e., notifications (page 4-155).
3. Specify the target host that will receive inform messages with the **snmp-server host** command as described in this section.
4. Create a view with the required notification messages (page 4-158).
5. Create a group that includes the required notify view (page 4-159).

To send an inform to a SNMPv3 host, complete these steps:

1. Enable the SNMP agent (page 4-150).
 2. Allow the switch to send SNMP traps; i.e., notifications (page 4-155).
 3. Specify the target host that will receive inform messages with the **snmp-server host** command as described in this section.
 4. Create a view with the required notification messages (page 4-158).
 5. Create a group that includes the required notify view (page 4-159).
 6. Specify a remote engine ID where the user resides (page 4-156).
 7. Then configure a remote user (page 4-162).
- The switch can send SNMP Version 1, 2c or 3 notifications to a host IP address, depending on the SNMP version that the management station

supports. If the **snmp-server host** command does not specify the SNMP version, the default is to send SNMP version 1 notifications.

- If you specify an SNMP Version 3 host, then the community string is interpreted as an SNMP user name. If you use the V3 “auth” or “priv” options, the user name must first be defined with the **snmp-server user** command. Otherwise, the authentication password and/or privacy password will not exist, and the switch will not authorize SNMP access for the host. However, if you specify a V3 host with the “noauth” option, an SNMP user account will be generated, and the switch will authorize SNMP access for the host.

Example

```
Console(config)#snmp-server host 10.1.19.23 batman
Console(config)#
```

Related Commands

snmp-server enable traps (4-155)

snmp-server enable traps

This command enables this device to send Simple Network Management Protocol traps or informs (i.e., SNMP notifications). Use the **no** form to disable SNMP notifications.

Syntax

[no] snmp-server enable traps [authentication | link-up-down]

- **authentication** - Keyword to issue authentication failure notifications.
- **link-up-down** - Keyword to issue link-up or link-down notifications.

Default Setting

Issue authentication and link-up-down traps.

Command Mode

Global Configuration

Command Usage

- If you do not enter an **snmp-server enable traps** command, no notifications controlled by this command are sent. In order to configure this device to send SNMP notifications, you must enter at least one **snmp-server enable traps** command. If you enter the command with no keywords, both authentication and link-up-down notifications are enabled. If you enter the command with a keyword, only the notification type related to that keyword is enabled.
- The **snmp-server enable traps** command is used in conjunction with the **snmp-server host** command. Use the **snmp-server host** command to specify which host or hosts receive SNMP notifications. In order to send notifications, you must configure at least one **snmp-server host** command.
- The authentication, link-up, and link-down traps are legacy notifications, and therefore when used for SNMP Version 3 hosts, they must be enabled in

conjunction with the corresponding entries in the Notify View assigned by the **snmp-server group** command (page 4-159).

Example

```
Console(config)#snmp-server enable traps link-up-down
Console(config)#
```

Related Commands

snmp-server host (4-153)

snmp-server engine-id

This command configures an identification string for the SNMPv3 engine. Use the **no** form to restore the default.

Syntax

```
snmp-server engine-id {local | remote {ip-address}} engineid-string
no snmp-server engine-id {local | remote {ip-address}}
```

- **local** - Specifies the SNMP engine on this switch.
- **remote** - Specifies an SNMP engine on a remote device.
- *ip-address* - The Internet address of the remote device.
- *engineid-string* - String identifying the engine ID.
(Range: 9-64 hexadecimal characters representing 5-32 octets)

Default Setting

A unique engine ID is automatically generated by the switch based on its MAC address.

Command Mode

Global Configuration

Command Usage

- An SNMP engine is an independent SNMP agent that resides either on this switch or on a remote device. This engine protects against message replay, delay, and redirection. The engine ID is also used in combination with user passwords to generate the security keys for authenticating and encrypting SNMPv3 packets.
- A remote engine ID is required when using SNMPv3 informs. (See **snmp-server host** on page 4-153.) The remote engine ID is used to compute the security digest for authenticating and encrypting packets sent to a user on the remote host. SNMP passwords are localized using the engine ID of the authoritative agent. For informs, the authoritative SNMP agent is the remote agent. You therefore need to configure the remote agent's SNMP engine ID before you can send proxy requests or informs to it.
- Trailing zeroes need not be entered to uniquely specify a engine ID. In other words, the value "123456789" is equivalent to "1234567890" because a trailing zero will be added to fill in the last octet if an odd number of hexadecimal characters is specified.

- A local engine ID is automatically generated that is unique to the switch. This is referred to as the default engine ID. If the local engine ID is deleted or changed, all SNMP users will be cleared. You will need to reconfigure all existing users (page 4-162).

Example

```
Console(config)#snmp-server engine-id local 123456789
Console(config)#snmp-server engineID remote 987654321 192.168.1.19
Console(config)#
```

Related Commands

snmp-server host (4-153)

show snmp engine-id

This command shows the SNMP engine ID.

Command Mode

Privileged Exec

Example

This example shows the default engine ID.

```
Console#show snmp engine-id
Local SNMP engineID: 8000002a8000000000e8666672
Local SNMP engineBoots: 1

Remote SNMP engineID                               IP address
80000000030004e2b316c54321                         192.168.1.19
Console#
```

Table 4-43 show snmp engine-id - display description

Field	Description
Local SNMP engineID	String identifying the engine ID.
Local SNMP engineBoots	The number of times that the engine has (re-)initialized since the snmp EngineID was last configured.
Remote SNMP engineID	String identifying an engine ID on a remote device.
IP address	IP address of the device containing the corresponding remote SNMP engine.

snmp-server view

This command adds an SNMP view which controls user access to the MIB. Use the **no** form to remove an SNMP view.

Syntax

snmp-server view *view-name oid-tree {included | excluded}*

no snmp-server view *view-name*

- *view-name* - Name of an SNMP view. (Range: 1-64 characters)
- *oid-tree* - Object identifier of a branch within the MIB tree. Wild cards can be used to mask a specific portion of the OID string. (Refer to the examples.)
- **included** - Defines an included view.
- **excluded** - Defines an excluded view.

Default Setting

defaultview (includes access to the entire MIB tree)

Command Mode

Global Configuration

Command Usage

- Views are used in the **snmp-server group** command to restrict user access to specified portions of the MIB tree.
- The predefined view “defaultview” includes access to the entire MIB tree.

Examples

This view includes MIB-2.

```
Console(config)#snmp-server view mib-2 1.3.6.1.2.1 included
Console(config)#
```

This view includes the MIB-2 interfaces table, ifDescr. The wild card is used to select all the index values in this table.

```
Console(config)#snmp-server view ifEntry.2 1.3.6.1.2.1.2.2.1.*.2 included
Console(config)#
```

This view includes the MIB-2 interfaces table, and the mask selects all index entries.

```
Console(config)#snmp-server view ifEntry.a 1.3.6.1.2.1.2.2.1.1.* included
Console(config)#
```

show snmp view

This command shows information on the SNMP views.

Command Mode

Privileged Exec

Example

```

Console#show snmp view
View Name: mib-2
Subtree OID: 1.2.2.3.6.2.1
View Type: included
Storage Type: permanent
Row Status: active

View Name: defaultview
Subtree OID: 1
View Type: included
Storage Type: volatile
Row Status: active

Console#

```

Table 4-44 show snmp view - display description

Field	Description
View Name	Name of an SNMP view.
Subtree OID	A branch in the MIB tree.
View Type	Indicates if the view is included or excluded.
Storage Type	The storage type for this entry.
Row Status	The row status of this entry.

snmp-server group

This command adds an SNMP group, mapping SNMP users to SNMP views. Use the **no** form to remove an SNMP group.

Syntax

```

snmp-server group groupname {v1 | v2c | v3 {auth | noauth | priv}}
[read readview] [write writeview] [notify notifyview]
no snmp-server group groupname

```

- *groupname* - Name of an SNMP group. (Range: 1-32 characters)
- **v1** | **v2c** | **v3** - Use SNMP version 1, 2c or 3.
- **auth** | **noauth** | **priv** - This group uses SNMPv3 with authentication, no authentication, or with authentication and privacy. See “Simple Network Management Protocol” on page 3-38 for further information about these authentication and encryption options.
- *readview* - Defines the view for read access. (1-64 characters)
- *writeview* - Defines the view for write access. (1-64 characters)
- *notifyview* - Defines the view for notifications. (1-64 characters)

Default Setting

- Default groups: public¹⁹ (read only), private²⁰ (read/write)
- *readview* - Every object belonging to the Internet OID space (1.3.6.1).
- *writeview* - Nothing is defined.
- *notifyview* - Nothing is defined.

Command Mode

Global Configuration

Command Usage

- A group sets the access policy for the assigned users.
- When authentication is selected, the MD5 or SHA algorithm is used as specified in the **snmp-server user** command.
- When privacy is selected, the DES 56-bit algorithm is used for data encryption.
- Note that the authentication, link-up and link-down messages are legacy traps and must therefore be enabled in conjunction with the **snmp-server enable traps** command (page 4-155).

Example

```
Console(config)#snmp-server group r&d v3 auth write daily
Console(config)#
```

show snmp group

Four default groups are provided – SNMPv1 read-only access and read/write access, and SNMPv2c read-only access and read/write access.

Command Mode

Privileged Exec

Example

```
Console#show snmp group
Group Name: r&d
Security Model: v3
Read View: defaultview
Write View: daily
Notify View: none
Storage Type: permanent
Row Status: active

Group Name: public
Security Model: v1
Read View: defaultview
Write View: none
Notify View: none
Storage Type: volatile
Row Status: active
```

19. No view is defined.

20. Maps to the defaultview.

```
Group Name: public
Security Model: v2c
Read View: defaultview
Write View: none
Notify View: none
Storage Type: volatile
Row Status: active

Group Name: private
Security Model: v1
Read View: defaultview
Write View: defaultview
Notify View: none
Storage Type: volatile
Row Status: active

Group Name: private
Security Model: v2c
Read View: defaultview
Write View: defaultview
Notify View: none
Storage Type: volatile
Row Status: active

Console#
```

Table 4-45 show snmp group - display description

Field	Description
groupname	Name of an SNMP group.
security model	The SNMP version.
readview	The associated read view.
writeview	The associated write view.
notifyview	The associated notify view.
storage-type	The storage type for this entry.
Row Status	The row status of this entry.

snmp-server user

This command adds a user to an SNMP group, restricting the user to a specific SNMP Read, Write, or Notify View. Use the **no** form to remove a user from an SNMP group.

Syntax

```
snmp-server user username groupname [remote ip-address] {v1 | v2c | v3
[encrypted] [auth {md5 | sha} auth-password [priv des56 priv-password]}
no snmp-server user username {v1 | v2c | v3 | remote}
```

- *username* - Name of user connecting to the SNMP agent.
(Range: 1-32 characters)
- *groupname* - Name of an SNMP group to which the user is assigned.
(Range: 1-32 characters)
- **remote** - Specifies an SNMP engine on a remote device.
- *ip-address* - The Internet address of the remote device.
- **v1** | **v2c** | **v3** - Use SNMP version 1, 2c or 3.
- **encrypted** - Accepts the password as encrypted input.
- **auth** - Uses SNMPv3 with authentication.
- **md5** | **sha** - Uses MD5 or SHA authentication.
- *auth-password* - Authentication password. Enter as plain text if the **encrypted** option is not used. Otherwise, enter an encrypted password. (A minimum of eight characters is required.)
- **priv des56** - Uses SNMPv3 with privacy with DES56 encryption.
- *priv-password* - Privacy password. Enter as plain text if the **encrypted** option is not used. Otherwise, enter an encrypted password.

Default Setting

None

Command Mode

Global Configuration

Command Usage

- The SNMP engine ID is used to compute the authentication/privacy digests from the password. You should therefore configure the engine ID with the **snmp-server engine-id** command before using this configuration command.
- Before you configure a remote user, use the **snmp-server engine-id** command (page 4-156) to specify the engine ID for the remote device where the user resides. Then use the **snmp-server user** command to specify the user and the IP address for the remote device where the user resides. The remote agent's SNMP engine ID is used to compute authentication/privacy digests from the user's password. If the remote engine ID is not first configured, the **snmp-server user** command specifying a remote user will fail.
- SNMP passwords are localized using the engine ID of the authoritative agent. For informs, the authoritative SNMP agent is the remote agent. You therefore need to configure the remote agent's SNMP engine ID before you can send proxy requests or informs to it.

Example

```
Console(config)#snmp-server user steve group r&d v3 auth md5 greenpeace
priv des56 einstien
Console(config)#snmp-server user mark group r&d remote 192.168.1.19 v3
auth md5 greenpeace priv des56 einstien
Console(config)#
```

show snmp user

This command shows information on SNMP users.

Command Mode

Privileged Exec

Example

```
Console#show snmp user
EngineId: 800000ca030030f1df9ca00000
User Name: steve
Authentication Protocol: md5
Privacy Protocol: des56
Storage Type: nonvolatile
Row Status: active

SNMP remote user
EngineId: 80000000030004e2b316c54321
User Name: mark
Authentication Protocol: mdt
Privacy Protocol: des56
Storage Type: nonvolatile
Row Status: active

Console#
```

Table 4-46 show snmp user - display description

Field	Description
EngineId	String identifying the engine ID.
User Name	Name of user connecting to the SNMP agent.
Authentication Protocol	The authentication protocol used with SNMPv3.
Privacy Protocol	The privacy protocol used with SNMPv3.
Storage Type	The storage type for this entry.
Row Status	The row status of this entry.
SNMP remote user	A user associated with an SNMP engine on a remote device.

Interface Commands

These commands are used to display or set communication parameters for an Ethernet port, aggregated link, or VLAN.

Table 4-1 Interface Commands

Command	Function	Mode	Page
interface	Configures an interface type and enters interface configuration mode	GC	4-166
description	Adds a description to an interface configuration	IC	4-167
speed-duplex	Configures the speed and duplex operation of a given interface when autonegotiation is disabled	IC	4-167
negotiation	Enables autonegotiation of a given interface	IC	4-168
capabilities	Advertises the capabilities of a given interface for use in autonegotiation	IC	4-169
flowcontrol	Enables flow control on a given interface	IC	4-170
shutdown	Disables an interface	IC	4-171
switchport packet-rate	Configures the broadcast storm control threshold	IC	4-172
clear counters	Clears statistics on an interface	PE	4-172
show interfaces status	Displays status for the specified interface	NE, PE	4-173
show interfaces counters	Displays statistics for the specified interfaces	NE, PE	4-174
show interfaces switchport	Displays the administrative and operational status of an interface	NE, PE	4-175

interface

This command configures an interface type and enters interface configuration mode. Use the **no** form to remove a trunk.

Syntax

interface *interface*

no interface port-channel *channel-id*

interface

- **ethernet** *unit/port*
 - *unit* - Stack unit. (Range: 1)
 - *port* - Port number. (Range: 1-28/52)
- **port-channel** *channel-id* (Range: 1-8)
- **vlan** *vlan-id* (Range: 1-4092)

Default Setting

None

Command Mode

Global Configuration

4 Command Line Interface

Example

To specify port 24, enter the following command:

```
Console(config)#interface ethernet 1/24
Console(config-if)#
```

description

This command adds a description to an interface. Use the **no** form to remove the description.

Syntax

description *string*
no description

string - Comment or a description to help you remember what is attached to this interface. (Range: 1-64 characters)

Default Setting

None

Command Mode

Interface Configuration (Ethernet, Port Channel)

Example

The following example adds a description to port 24.

```
Console(config)#interface ethernet 1/24
Console(config-if)#description RD-SW#3
Console(config-if)#
```

speed-duplex

This command configures the speed and duplex mode of a given interface when autonegotiation is disabled. Use the **no** form to restore the default.

Syntax

speed-duplex {**1000full** | **100full** | **100half** | **10full** | **10half**}
no speed-duplex

- **1000full** - Forces 1000 Mbps full-duplex operation
- **100full** - Forces 100 Mbps full-duplex operation
- **100half** - Forces 100 Mbps half-duplex operation
- **10full** - Forces 10 Mbps full-duplex operation
- **10half** - Forces 10 Mbps half-duplex operation

Note: 1000full operation cannot be forced. The Gigabit Combo ports can only operate at 1000full when auto-negotiation is enabled.

Default Setting

- Auto-negotiation is enabled by default.

- When auto-negotiation is disabled, the default speed-duplex setting for both 100BASE-TX and Gigabit Ethernet ports is 100full.

Command Mode

Interface Configuration (Ethernet, Port Channel)

Command Usage

- To force operation to the speed and duplex mode specified in a **speed-duplex** command, use the **no negotiation** command to disable auto-negotiation on the selected interface.
- When using the **negotiation** command to enable auto-negotiation, the optimal settings will be determined by the **capabilities** command. To set the speed/duplex mode under auto-negotiation, the required mode must be specified in the capabilities list for an interface.

Example

The following example configures port 5 to 100 Mbps, half-duplex operation.

```
Console(config)#interface ethernet 1/5
Console(config-if)#speed-duplex 100half
Console(config-if)#no negotiation
Console(config-if)#
```

Related Commands

negotiation (4-168)
capabilities (4-169)

negotiation

This command enables autonegotiation for a given interface. Use the **no** form to disable autonegotiation.

Syntax

[no] negotiation

Default Setting

Enabled

Command Mode

Interface Configuration (Ethernet, Port Channel)

Command Usage

- When auto-negotiation is enabled the switch will negotiate the best settings for a link based on the **capabilities** command. When auto-negotiation is disabled, you must manually specify the link attributes with the **speed-duplex** and **flowcontrol** commands.
- If autonegotiation is disabled, auto-MDI/MDI-X pin signal configuration will also be disabled for the RJ-45 ports.

Example

The following example configures port 11 to use autonegotiation.

```
Console(config)#interface ethernet 1/11
Console(config-if)#negotiation
Console(config-if)#
```

Related Commands

- capabilities (4-169)
- speed-duplex (4-167)

capabilities

This command advertises the port capabilities of a given interface during autonegotiation. Use the **no** form with parameters to remove an advertised capability, or the **no** form without parameters to restore the default values.

Syntax

[no] **capabilities** {**1000full** | **100full** | **100half** | **10full** | **10half** | **flowcontrol** | **symmetric**}

- **1000full** - Supports 1000 Mbps full-duplex operation
- **100full** - Supports 100 Mbps full-duplex operation
- **100half** - Supports 100 Mbps half-duplex operation
- **10full** - Supports 10 Mbps full-duplex operation
- **10half** - Supports 10 Mbps half-duplex operation
- **flowcontrol** - Supports flow control
- **symmetric** (Gigabit only) - When specified, the port transmits and receives pause frames; when not specified, the port will auto-negotiate to determine the sender and receiver for asymmetric pause frames. (*The current switch ASIC only supports symmetric pause frames.*)

Default Setting

- 100BASE-TX: 10half, 10full, 100half, 100full
- 1000BASE-T: 10half, 10full, 100half, 100full, 1000full
- SFP: 1000full

Command Mode

Interface Configuration (Ethernet, Port Channel)

Command Usage

When auto-negotiation is enabled with the **negotiation** command, the switch will negotiate the best settings for a link based on the **capabilities** command. When auto-negotiation is disabled, you must manually specify the link attributes with the **speed-duplex** and **flowcontrol** commands.

Example

The following example configures Ethernet port 5 capabilities to 100half, 100full and flow control.

```
Console(config)#interface ethernet 1/5
Console(config-if)#capabilities 100half
Console(config-if)#capabilities 100full
Console(config-if)#capabilities flowcontrol
Console(config-if)#
```

Related Commands

negotiation (4-168)
speed-duplex (4-167)
flowcontrol (4-170)

flowcontrol

This command enables flow control. Use the **no** form to disable flow control.

Syntax

[no] flowcontrol

Default Setting

Disabled

Command Mode

Interface Configuration (Ethernet, Port Channel)

Command Usage

- Flow control can eliminate frame loss by “blocking” traffic from end stations or segments connected directly to the switch when its buffers fill. When enabled, back pressure is used for half-duplex operation and IEEE 802.3x for full-duplex operation.
- To force flow control on or off (with the **flowcontrol** or **no flowcontrol** command), use the **no negotiation** command to disable auto-negotiation on the selected interface.
- When using the **negotiation** command to enable auto-negotiation, the optimal settings will be determined by the **capabilities** command. To enable flow control under auto-negotiation, “flowcontrol” must be included in the capabilities list for any port
- Avoid using flow control on a port connected to a hub unless it is actually required to solve a problem. Otherwise back pressure jamming signals may degrade overall performance for the segment attached to the hub.

4 Command Line Interface

Example

The following example enables flow control on port 5.

```
Console(config)#interface ethernet 1/5
Console(config-if)#flowcontrol
Console(config-if)#no negotiation
Console(config-if)#
```

Related Commands

negotiation (4-168)

capabilities (flowcontrol, symmetric) (4-169)

shutdown

This command disables an interface. To restart a disabled interface, use the **no** form.

Syntax

[no] shutdown

Default Setting

All interfaces are enabled.

Command Mode

Interface Configuration (Ethernet, Port Channel)

Command Usage

This command allows you to disable a port due to abnormal behavior (e.g., excessive collisions), and then reenable it after the problem has been resolved. You may also want to disable a port for security reasons.

Example

The following example disables port 5.

```
Console(config)#interface ethernet 1/5
Console(config-if)#shutdown
Console(config-if)#
```

switchport packet-rate

This command configures broadcast and multicast and unknown unicast storm control. Use the **no** form to restore the default setting.

Syntax

switchport broadcast packet-rate *rate*
no switchport broadcast

- **broadcast** - Specifies storm control for broadcast traffic.
- **rate** - Threshold level as a rate; i.e., kilobits per second.
(Range: 64-100000 for 100 Mbps ports, 64-1000000 for 1 Gbps ports)

Default Setting

Broadcast Storm Control: Enabled, packet-rate limit: 64 kbps

Command Mode

Interface Configuration (Ethernet)

Command Usage

When traffic exceeds the threshold specified for broadcast and multicast or unknown unicast traffic, packets exceeding the threshold are dropped until the rate falls back down beneath the threshold.

Example

The following shows how to configure broadcast storm control at 500 kilobits per second:

```
Console(config)#interface ethernet 1/5
Console(config-if)#switchport broadcast packet-rate 500
Console(config-if)#
```

clear counters

This command clears statistics on an interface.

Syntax

clear counters *interface*
interface

- **ethernet** *unit/port*
 - *unit* - Stack unit. (Range: 1)
 - *port* - Port number. (Range: 1-28/52)
- **port-channel** *channel-id* (Range: 1-8)

Default Setting

None

Command Mode

Privileged Exec

Command Usage

Statistics are only initialized for a power reset. This command sets the base value for displayed statistics to zero for the current management session. However, if you log out and back into the management interface, the statistics displayed will show the absolute value accumulated since the last power reset.

Example

The following example clears statistics on port 5.

```
Console#clear counters ethernet 1/5
Console#
```

show interfaces status

This command displays the status for an interface.

Syntax

show interfaces status [*interface*]

interface

- **ethernet** *unit/port*
 - *unit* - Stack unit. (Range: 1)
 - *port* - Port number. (Range: 1-28/52)
- **port-channel** *channel-id* (Range: 1-8)
- **vlan** *vlan-id* (Range: 1-4092)

Default Setting

Shows the status for all interfaces.

Command Mode

Normal Exec, Privileged Exec

Command Usage

If no interface is specified, information on all interfaces is displayed. For a description of the items displayed by this command, see “Displaying Connection Status” on page 3-110.

Example

```

Console#show interfaces status ethernet 1/5
Information of Eth 1/5
Basic information:
  Port type:                100TX
  Mac address:              00-12-CF-12-34-61
Configuration:
  Name:
  Port admin:              Up
  Speed-duplex:            Auto
  Capabilities:            10half, 10full, 100half, 100full,
  Broadcast storm:        Enabled
  Broadcast storm limit:   64 Kbits/second
  Flow control:            Disabled
  LACP:                    Disabled
  Port security:          Disabled
  Max MAC count:          0
  Port security action:    None
Current status:
  Link status:             Up
  Port operation status:   Up
  Operation speed-duplex:  100full
  Flow control type:      None
Console#show interfaces status vlan 1
Information of VLAN 1
  MAC address:             00-12-CF-12-34-56
Console#

```

show interfaces counters

This command displays interface statistics.

Syntax

show interfaces counters [*interface*]

interface

- **ethernet** *unit/port*
 - *unit* - Stack unit. (Range: 1)
 - *port* - Port number. (Range: 1-28/52)
- **port-channel** *channel-id* (Range: 1-8)

Default Setting

Shows the counters for all interfaces.

Command Mode

Normal Exec, Privileged Exec

Command Usage

If no interface is specified, information on all interfaces is displayed. For a description of the items displayed by this command, see "Showing Port Statistics" on page 3-129.

Example

```
Console#show interfaces counters ethernet 1/7
Ethernet 1/7
Iftable stats:
  Octets input: 30658, Octets output: 196550
  Unicast input: 6, Unicast output: 5
  Discard input: 0, Discard output: 0
  Error input: 0, Error output: 0
  Unknown protos input: 0, QLen output: 0
Extended iftable stats:
  Multi-cast input: 0, Multi-cast output: 3064
  Broadcast input: 262, Broadcast output: 1
Ether-like stats:
  Alignment errors: 0, FCS errors: 0
  Single Collision frames: 0, Multiple collision frames: 0
  SQE Test errors: 0, Deferred transmissions: 0
  Late collisions: 0, Excessive collisions: 0
  Internal mac transmit errors: 0, Internal mac receive errors: 0
  Frame too longs: 0, Carrier sense errors: 0
  Symbol errors: 0
RMON stats:
  Drop events: 0, Octets: 227208, Packets: 3338
  Broadcast pkts: 263, Multi-cast pkts: 3064
  Undersize pkts: 0, Oversize pkts: 0
  Fragments: 0, Jabbers: 0
  CRC align errors: 0, Collisions: 0
  Packet size <= 64 octets: 3150, Packet size 65 to 127 octets: 139
  Packet size 128 to 255 octets: 49, Packet size 256 to 511 octets: 0
  Packet size 512 to 1023 octets: 0, Packet size 1024 to 1518 octets: 0
Console#
```

show interfaces switchport

This command displays the administrative and operational status of the specified interfaces.

Syntax

```
show interfaces switchport [interface]
```

interface

- **ethernet** *unit/port*
 - *unit* - Stack unit. (Range: 1)
 - *port* - Port number. (Range: 1-28/52)
- **port-channel** *channel-id* (Range: 1-8)

Default Setting

Shows all interfaces.

Command Mode

Normal Exec, Privileged Exec

Command Usage

If no interface is specified, information on all interfaces is displayed.

Example

This example shows the configuration setting for port 24.

```

Console#show interfaces switchport ethernet 1/24
Broadcast threshold:      Enabled, 64 Kbits/second
LACP status:             Enabled
Ingress Rate Limit:      Disabled, 100000 Kbits per second
Egress Rate Limit:       Disabled, 100000 Kbits per second
VLAN membership mode:    Hybrid
Ingress rule:            Enabled
Acceptable frame type:   All frames
Native VLAN:             1
Priority for untagged traffic: 0
Gvrp status:             Disabled
Allowed Vlan:            1(u),
Forbidden Vlan:
Private-VLAN mode:       NONE
Private-VLAN host-association: NONE
Private-VLAN mapping:    NONE
Console#

```

Table 4-2 Interfaces Switchport Statistics

Field	Description
Broadcast threshold	Shows if broadcast storm suppression is enabled or disabled; if enabled it also shows the threshold level (page 4-172).
Lacp status	Shows if Link Aggregation Control Protocol has been enabled or disabled (page 4-182).
Ingress rate limit	Shows if ingress rate limiting is enabled, and the current rate limit. (page 4-179).
Egress rate limit	Shows if egress rate limiting is enabled, and the current rate limit. (page 4-179).
VLAN membership mode	Indicates membership mode as Trunk or Hybrid (page 4-245).
Ingress rule	Shows if ingress filtering is enabled or disabled (page 4-246). Note: Ingress filtering is always enabled.
Acceptable frame type	Shows if acceptable VLAN frames include all types or tagged frames only (page 4-246).
Native VLAN	Indicates the default Port VLAN ID (page 4-247).
Priority for untagged traffic	Indicates the default priority for untagged frames (page 4-264).
Gvrp status	Shows if GARP VLAN Registration Protocol is enabled or disabled (page 4-240).
Allowed Vlan	Shows the VLANs this interface has joined, where "(u)" indicates untagged and "(t)" indicates tagged (page 4-248).
Forbidden Vlan	Shows the VLANs this interface can not dynamically join via GVRP (page 4-249).
Private VLAN mode	Shows the private VLAN mode as host, promiscuous, or none (4-257).
Private VLAN host-association	Shows the secondary (or community) VLAN with which this port is associated (4-258).
Private VLAN mapping	Shows the primary VLAN mapping for a promiscuous port (4-259).

Mirror Port Commands

This section describes how to mirror traffic from a source port to a target port.

Table 4-3 Mirror Port Commands

Command	Function	Mode	Page
port monitor	Configures a mirror session	IC	4-177
show port monitor	Shows the configuration for a mirror port	PE	4-178

port monitor

This command configures a mirror session. Use the **no** form to clear a mirror session.

Syntax

port monitor *interface* [**rx** | **tx**]
no port monitor *interface*

- *interface* - **ethernet unit/port** (source port)
 - *unit* - Stack unit. (Range: 1)
 - *port* - Port number. (Range: 1-28/52)
- **rx** - Mirror received packets.
- **tx** - Mirror transmitted packets.

Default Setting

No mirror session is defined.

Command Mode

Interface Configuration (Ethernet, destination port)

Command Usage

- You can mirror traffic from any source port to a destination port for real-time analysis. You can then attach a logic analyzer or RMON probe to the destination port and study the traffic crossing the source port in a completely unobtrusive manner.
- The destination port is set by specifying an Ethernet interface.
- The mirror port and monitor port speeds should match, otherwise traffic may be dropped from the monitor port.
- All mirror sessions must share the same destination port.
- When mirroring port traffic, the target port must be included in the same VLAN as the source port

Example

The following example configures the switch to mirror received packets from port 6 to 11:

```
Console(config)#interface ethernet 1/11
Console(config-if)#port monitor ethernet 1/6 rx
Console(config-if)#
```

show port monitor

This command displays mirror information.

Syntax

show port monitor [*interface*]

interface - **ethernet** *unit/port* (source port)

- *unit* - Stack unit. (Range: 1)
- *port* - Port number. (Range: 1-28/52)

Default Setting

Shows all sessions.

Command Mode

Privileged Exec

Command Usage

This command displays the currently configured source port, destination port, and mirror mode (i.e., RX, TX).

Example

The following shows mirroring configured from port 6 to port 11:

```
Console(config)#interface ethernet 1/11
Console(config-if)#port monitor ethernet 1/6 rx
Console(config-if)#end
Console#show port monitor
Port Mirroring
-----
Destination port(listen port):Eth1/11
Source port(monitored port) :Eth1/6
Mode                        :RX
Console#
```

Rate Limit Commands

This function allows the network manager to control the maximum rate for traffic received on an interface. Rate limiting is configured on interfaces at the edge of a network to limit traffic into the network. Packets that exceed the acceptable amount of traffic are dropped.

Rate limiting can be applied to individual ports or trunks. When an interface is configured with this feature, the traffic rate will be monitored by the hardware to verify conformity. Non-conforming traffic is dropped.

Table 4-4 Rate Limit Commands

Command	Function	Mode	Page
rate-limit	Configures the maximum input rate for a port	IC	4-179

rate-limit

Use this command to define the rate limit level for a specific interface. Use this command without specifying a rate to restore the default rate limit level. Use the **no** form to restore the default status of disabled.

Syntax

rate-limit <input | output> [*rate*]

no rate-limit <input | output>

- **input** – Input rate limit
- **output** – Input rate limit
- *rate* – The traffic rate limit level. Range: 64-100000 kilobits per second for 100 Mbps ports; 64-1000000 kilobits per second for 1 Gbps ports

Default Setting

Input/Output Rate Limit Status: Disabled

Rate level: 100000 kilobits per second for 100 Mbps ports; 1000000 kilobits per second for 1 Gbps ports

Command Mode

Interface Configuration (Ethernet, Port Channel)

Example

```
Console(config)#interface ethernet 1/1
Console(config-if)#rate-limit input 2000
Console(config-if)#
```

Link Aggregation Commands

Ports can be statically grouped into an aggregate link (i.e., trunk) to increase the bandwidth of a network connection or to ensure fault recovery. Or you can use the Link Aggregation Control Protocol (LACP) to automatically negotiate a trunk link between this switch and another network device. For static trunks, the switches have to comply with the Cisco EtherChannel standard. For dynamic trunks, the switches have to comply with LACP. This switch supports up to four trunks. For example, a trunk consisting of two 1000 Mbps ports can support an aggregate bandwidth of 4 Gbps when operating at full duplex.

Table 4-5 Link Aggregation Commands

Command	Function	Mode	Page
<i>Manual Configuration Commands</i>			
interface port-channel	Configures a trunk and enters interface configuration mode for the trunk	GC	4-166
channel-group	Adds a port to a trunk	IC (Ethernet)	4-181
<i>Dynamic Configuration Command</i>			
lACP	Configures LACP for the current interface	IC (Ethernet)	4-182
lACP system-priority	Configures a port's LACP system priority	IC (Ethernet)	4-183
lACP admin-key	Configures a port's administration key	IC (Ethernet)	4-184
lACP admin-key	Configures an port channel's administration key	IC (Port Channel)	4-185
lACP port-priority	Configures a port's LACP port priority	IC (Ethernet)	4-186
<i>Trunk Status Display Command</i>			
show interfaces status port-channel	Shows trunk information	NE, PE	4-173
show lACP	Shows LACP information	PE	4-186

Guidelines for Creating Trunks

General Guidelines –

- Finish configuring port trunks before you connect the corresponding network cables between switches to avoid creating a loop.
- A trunk can have up to eight ports.
- The ports at both ends of a connection must be configured as trunk ports.
- All ports in a trunk must be configured in an identical manner, including communication mode (i.e., speed, duplex mode and flow control), VLAN assignments, and CoS settings.
- All the ports in a trunk have to be treated as a whole when moved from/to, added or deleted from a VLAN via the specified port-channel.
- STP, VLAN, and IGMP settings can only be made for the entire trunk via the specified port-channel.

Dynamically Creating a Port Channel –

Ports assigned to a common port channel must meet the following criteria:

- Ports must have the same LACP system priority.
- Ports must have the same port admin key (Ethernet Interface).
- If the port channel admin key (lacp admin key - Port Channel) is not set when a channel group is formed (i.e., it has the null value of 0), this key is set to the same value as the port admin key (lacp admin key - Ethernet Interface) used by the interfaces that joined the group.
- However, if the port channel admin key is set, then the port admin key must be set to the same value for a port to be allowed to join a channel group.
- If a link goes down, LACP port priority is used to select the backup link.

channel-group

This command adds a port to a trunk. Use the **no** form to remove a port from a trunk.

Syntax

```
channel-group channel-id  
no channel-group
```

channel-id - Trunk index (Range: 1-8)

Default Setting

The current port will be added to this trunk.

Command Mode

Interface Configuration (Ethernet)

Command Usage

- When configuring static trunks, the switches must comply with the Cisco EtherChannel standard.
- Use **no channel-group** to remove a port group from a trunk.
- Use **no interfaces port-channel** to remove a trunk from the switch.

Example

The following example creates trunk 1 and then adds port 11:

```
Console(config)#interface port-channel 1
Console(config-if)#exit
Console(config)#interface ethernet 1/11
Console(config-if)#channel-group 1
Console(config-if)#
```

lACP

This command enables 802.3ad Link Aggregation Control Protocol (LACP) for the current interface. Use the **no** form to disable it.

Syntax

[no] lACP

Default Setting

Disabled

Command Mode

Interface Configuration (Ethernet)

Command Usage

- The ports on both ends of an LACP trunk must be configured for full duplex, and auto-negotiation.
- A trunk formed with another switch using LACP will automatically be assigned the next available port-channel ID.
- If the target switch has also enabled LACP on the connected ports, the trunk will be activated automatically.
- If more than eight ports attached to the same target switch have LACP enabled, the additional ports will be placed in standby mode, and will only be enabled if one of the active links fails.

Example

The following shows LACP enabled on ports 11-13. Because LACP has also been enabled on the ports at the other end of the links, the **show interfaces status port-channel 1** command shows that Trunk 1 has been established.

```
Console(config)#interface ethernet 1/11
Console(config-if)#lACP
Console(config-if)#exit
Console(config)#interface ethernet 1/12
Console(config-if)#lACP
Console(config-if)#exit
Console(config)#interface ethernet 1/13
Console(config-if)#lACP
Console(config-if)#exit
Console(config)#exit
Console#show interfaces status port-channel 1
Information of Trunk 1
Basic information:
  Port type:          100TX
  Mac address:       00-12-CF-12-34-72
Configuration:
  Name:
  Port admin:       Up
  Speed-duplex:    Auto
  Capabilities:    10half, 10full, 100half, 100full
  Flow control status: Disabled
  Port security:   Disabled
  Max MAC count:   0
Current status:
  Created by:      LACP
  Link status:     Up
  Operation speed-duplex: 100full
  Flow control type: None
  Member Ports:   Eth1/11, Eth1/12, Eth1/13,
Console#
```

lACP system-priority

This command configures a port's LACP system priority. Use the **no** form to restore the default setting.

Syntax

```
lACP {actor | partner} system-priority priority
no lACP {actor | partner} system-priority
```

- **actor** - The local side an aggregate link.
- **partner** - The remote side of an aggregate link.
- **priority** - This priority is used to determine link aggregation group (LAG) membership, and to identify this device to other switches during LAG negotiations. (Range: 0-65535)

Default Setting

32768

Command Mode

Interface Configuration (Ethernet)

Command Usage

- Port must be configured with the same system priority to join the same LAG.
- System priority is combined with the switch's MAC address to form the LAG identifier. This identifier is used to indicate a specific LAG during LACP negotiations with other systems.
- Once the remote side of a link has been established, LACP operational settings are already in use on that side. Configuring LACP settings for the partner only applies to its administrative state, not its operational state, and will only take effect the next time an aggregate link is established with the partner.

Example

```
Console(config)#interface ethernet 1/5
Console(config-if)#lACP actor system-priority 3
Console(config-if)#
```

lACP admin-key (Ethernet Interface)

This command configures a port's LACP administration key. Use the **no** form to restore the default setting.

Syntax

```
lACP {actor | partner} admin-key key
[no] lACP {actor | partner} admin-key
```

- **actor** - The local side an aggregate link.
- **partner** - The remote side of an aggregate link.
- **key** - The port admin key must be set to the same value for ports that belong to the same link aggregation group (LAG). (Range: 0-65535)

Default Setting

0

Command Mode

Interface Configuration (Ethernet)

Command Usage

- Ports are only allowed to join the same LAG if (1) the LACP system priority matches, (2) the LACP port admin key matches, and (3) the LACP port channel key matches (if configured).
- If the port channel admin key (**lACP admin key** - Port Channel) is not set when a channel group is formed (i.e., it has the null value of 0), this key is set to the same value as the port admin key (**lACP admin key** - Ethernet Interface) used by the interfaces that joined the group.

4 Command Line Interface

- Once the remote side of a link has been established, LACP operational settings are already in use on that side. Configuring LACP settings for the partner only applies to its administrative state, not its operational state, and will only take effect the next time an aggregate link is established with the partner.

Example

```
Console(config)#interface ethernet 1/5
Console(config-if)#lACP actor admin-key 120
Console(config-if)#
```

lACP admin-key (Port Channel)

This command configures a port channel's LACP administration key string. Use the **no** form to restore the default setting.

Syntax

```
lACP {actor | partner} admin-key key
[no] lACP {actor | partner} admin-key
```

key - The port channel admin key is used to identify a specific link aggregation group (LAG) during local LACP setup on this switch. (Range: 0-65535)

Default Setting

0

Command Mode

Interface Configuration (Port Channel)

Command Usage

- Ports are only allowed to join the same LAG if (1) the LACP system priority matches, (2) the LACP port admin key matches, and (3) the LACP port channel key matches (if configured).
- If the port channel admin key (**lACP admin key** - Port Channel) is not set when a channel group is formed (i.e., it has the null value of 0), this key is set to the same value as the port admin key (**lACP admin key** - Ethernet Interface) used by the interfaces that joined the group. Note that when the LAG is no longer used, the port channel admin key is reset to 0.

Example

```
Console(config)#interface port-channel 1
Console(config-if)#lACP actor admin-key 3
Console(config-if)#
```

lACP port-priority

This command configures LACP port priority. Use the **no** form to restore the default setting.

Syntax

```
lACP {actor | partner} port-priority priority  
no lACP {actor | partner} port-priority
```

- **actor** - The local side an aggregate link.
- **partner** - The remote side of an aggregate link.
- *priority* - LACP port priority is used to select a backup link. (Range: 0-65535)

Default Setting

32768

Command Mode

Interface Configuration (Ethernet)

Command Usage

- Setting a lower value indicates a higher effective priority.
- If an active port link goes down, the backup port with the highest priority is selected to replace the downed link. However, if two or more ports have the same LACP port priority, the port with the lowest physical port number will be selected as the backup port.
- Once the remote side of a link has been established, LACP operational settings are already in use on that side. Configuring LACP settings for the partner only applies to its administrative state, not its operational state, and will only take effect the next time an aggregate link is established with the partner.

Example

```
Console(config)#interface ethernet 1/5  
Console(config-if)#lACP actor port-priority 128
```

show lACP

This command displays LACP information.

Syntax

```
show lACP [port-channel] {counters | internal | neighbors | sysid}
```

- *port-channel* - Local identifier for a link aggregation group. (Range: 1-8)
- **counters** - Statistics for LACP protocol messages.
- **internal** - Configuration settings and operational state for local side.
- **neighbors** - Configuration settings and operational state for remote side.
- **sysid** - Summary of system priority and MAC address for all channel groups.

Default Setting

Port Channel: all

Command Mode

Privileged Exec

Example

```

Console#show lacp 1 counters
Port channel : 1
-----
Eth 1/ 1
-----
  LACPDUs Sent : 21
  LACPDUs Received : 21
  Marker Sent : 0
  Marker Received : 0
  LACPDUs Unknown Pkts : 0
  LACPDUs Illegal Pkts : 0
  :
  :
```

Table 4-6 show lacp counters - display description

Field	Description
LACPDUs Sent	Number of valid LACPDUs transmitted from this channel group.
LACPDUs Received	Number of valid LACPDUs received on this channel group.
Marker Sent	Number of valid Marker PDUs transmitted from this channel group.
Marker Received	Number of valid Marker PDUs received by this channel group.
LACPDUs Unknown Pkts	Number of frames received that either (1) Carry the Slow Protocols Ethernet Type value, but contain an unknown PDU, or (2) are addressed to the Slow Protocols group MAC Address, but do not carry the Slow Protocols Ethernet Type.
LACPDUs Illegal Pkts	Number of frames that carry the Slow Protocols Ethernet Type value, but contain a badly formed PDU or an illegal value of Protocol Subtype.

```

Console#show lacp 1 internal
Port channel : 1
-----
Oper Key : 4
Admin Key : 0
Eth 1/1
-----
  LACPDUs Internal : 30 sec
  LACP System Priority : 32768
  LACP Port Priority : 32768
  Admin Key : 4
  Oper Key : 4
  Admin State : defaulted, aggregation, long timeout, LACP-activity
  Oper State : distributing, collecting, synchronization, aggregation,
                long timeout, LACP-activity
  :
  :
```

Table 4-7 show lacp internal - display description

Field	Description
Oper Key	Current operational value of the key for the aggregation port.
Admin Key	Current administrative value of the key for the aggregation port.
LACPDUs Internal	Number of seconds before invalidating received LACPDU information.
LACP System Priority	LACP system priority assigned to this port channel.
LACP Port Priority	LACP port priority assigned to this interface within the channel group.
Admin State, Oper State	Administrative or operational values of the actor's state parameters: <ul style="list-style-type: none"> Expired – The actor's receive machine is in the expired state; Defaulted – The actor's receive machine is using defaulted operational partner information, administratively configured for the partner. Distributing – If false, distribution of outgoing frames on this link is disabled; i.e., distribution is currently disabled and is not expected to be enabled in the absence of administrative changes or changes in received protocol information. Collecting – Collection of incoming frames on this link is enabled; i.e., collection is currently enabled and is not expected to be disabled in the absence of administrative changes or changes in received protocol information. Synchronization – The System considers this link to be IN_SYNC; i.e., it has been allocated to the correct Link Aggregation Group, the group has been associated with a compatible Aggregator, and the identity of the Link Aggregation Group is consistent with the System ID and operational Key information transmitted. Aggregation – The system considers this link to be aggregatable; i.e., a potential candidate for aggregation. Long timeout – Periodic transmission of LACPDUs uses a slow transmission rate. LACP-Activity – Activity control value with regard to this link. (0: Passive; 1: Active)

```

Console#show lacp 1 neighbors
Port channel 1 neighbors
-----
Eth 1/1
-----
Partner Admin System ID : 32768, 00-00-00-00-00-00
Partner Oper System ID : 32768, 00-00-00-00-00-01
Partner Admin Port Number : 1
Partner Oper Port Number : 1
Port Admin Priority : 32768
Port Oper Priority : 32768
Admin Key : 0
Oper Key : 4
Admin State : defaulted, distributing, collecting, synchronization,
              long timeout,
Oper State : distributing, collecting, synchronization, aggregation,
              long timeout, LACP-activity
:

```

Table 4-8 show lacp neighbors - display description

Field	Description
Partner Admin System ID	LAG partner's system ID assigned by the user.
Partner Oper System ID	LAG partner's system ID assigned by the LACP protocol.
Partner Admin Port Number	Current administrative value of the port number for the protocol Partner.
Partner Oper Port Number	Operational port number assigned to this aggregation port by the port's protocol partner.
Port Admin Priority	Current administrative value of the port priority for the protocol partner.
Port Oper Priority	Priority value assigned to this aggregation port by the partner.
Admin Key	Current administrative value of the Key for the protocol partner.
Oper Key	Current operational value of the Key for the protocol partner.
Admin State	Administrative values of the partner's state parameters. (See preceding table.)
Oper State	Operational values of the partner's state parameters. (See preceding table.)

```

Console#show lacp sysid
Port Channel      System Priority    System MAC Address
-----
                1                32768             00-12-CF-8F-2C-A7
                2                32768             00-12-CF-8F-2C-A7
                3                32768             00-12-CF-8F-2C-A7
                4                32768             00-12-CF-8F-2C-A7
Console#

```

Table 4-9 show lacp sysid - display description

Field	Description
Channel group	A link aggregation group configured on this switch.
System Priority*	LACP system priority for this channel group.
System MAC Address*	System MAC address.

* The LACP system priority and system MAC address are concatenated to form the LAG system ID.

Address Table Commands

These commands are used to configure the address table for filtering specified addresses, displaying current entries, clearing the table, or setting the aging time.

Table 4-10 Address Table Commands

Command	Function	Mode	Page
mac-address-table static	Maps a static address to a port in a VLAN	GC	4-190
clear mac-address-table dynamic	Removes any learned entries from the forwarding database	PE	4-191
show mac-address-table	Displays entries in the bridge-forwarding database	PE	4-191
mac-address-table aging-time	Sets the aging time of the address table	GC	4-192
show mac-address-table aging-time	Shows the aging time for the address table	PE	4-193

mac-address-table static

This command maps a static address to a destination port in a VLAN. Use the **no** form to remove an address.

Syntax

```
mac-address-table static mac-address interface interface
vlan vlan-id [action]
no mac-address-table static mac-address vlan vlan-id
```

- *mac-address* - MAC address.
- *interface*
 - **ethernet** *unit/port*
 - *unit* - Stack unit. (Range: 1)
 - *port* - Port number. (Range: 1-28/52)
 - **port-channel** *channel-id* (Range: 1-8)
- *vlan-id* - VLAN ID (Range: 1-4092)
- *action* -
 - **delete-on-reset** - Assignment lasts until the switch is reset.
 - **permanent** - Assignment is permanent.

Default Setting

No static addresses are defined. The default mode is **permanent**.

Command Mode

Global Configuration

Command Usage

The static address for a host device can be assigned to a specific port within a specific VLAN. Use this command to add static addresses to the MAC Address Table. Static addresses have the following characteristics:

- Static addresses will not be removed from the address table when a given interface link is down.
- Static addresses are bound to the assigned interface and will not be moved. When a static address is seen on another interface, the address will be ignored and will not be written to the address table.
- A static address cannot be learned on another port until the address is removed with the **no** form of this command.

Example

```
Console(config)#mac-address-table static 00-12-cf-94-34-de interface
 ethernet 1/1 vlan 1 delete-on-reset
Console(config)#
```

clear mac-address-table dynamic

This command removes any learned entries from the forwarding database and clears the transmit and receive counts for any static or system configured entries.

Default Setting

None

Command Mode

Privileged Exec

Example

```
Console#clear mac-address-table dynamic
Console#
```

show mac-address-table

This command shows classes of entries in the bridge-forwarding database.

Syntax

```
show mac-address-table [address mac-address [mask]] [interface interface]
 [vlan vlan-id] [sort {address | vlan | interface}]
```

- *mac-address* - MAC address.
- *mask* - Bits to match in the address.
- *interface*
 - **ethernet** *unit/port*
 - *unit* - Stack unit. (Range: 1)
 - *port* - Port number. (Range: 1-28/52)
 - **port-channel** *channel-id* (Range: 1-8)
- *vlan-id* - VLAN ID (Range: 1-4092)

- **sort** - Sort by address, vlan or interface.

Default Setting

None

Command Mode

Privileged Exec

Command Usage

- The MAC Address Table contains the MAC addresses associated with each interface. Note that the Type field may include the following types:
 - Learned - Dynamic address entries
 - Permanent - Static entry
 - Delete-on-reset - Static entry to be deleted when system is reset
- The mask should be hexadecimal numbers (representing an equivalent bit mask) in the form xx-xx-xx-xx-xx-xx that is applied to the specified MAC address. Enter hexadecimal numbers, where an equivalent binary bit “0” means to match a bit and “1” means to ignore a bit. For example, a mask of 00-00-00-00-00-00 means an exact match, and a mask of FF-FF-FF-FF-FF-FF means “any.”
- The maximum number of address entries is 8191.

Example

```

Console#show mac-address-table
Interface Mac Address          Vlan Type
-----
Eth 1/1 00-12-cf-94-34-de      1 Delete-on-reset
Trunk 2 00-12-cf-8f-aa-1b      1 Learned
Console#

```

mac-address-table aging-time

This command sets the aging time for entries in the address table. Use the **no** form to restore the default aging time.

Syntax

mac-address-table aging-time *seconds*

no mac-address-table aging-time

seconds - Aging time. (Range: 10-30000 seconds; 0 to disable aging)

Default Setting

300 seconds

Command Mode

Global Configuration

Command Usage

The aging time is used to age out dynamically learned forwarding information.

Example

```
Console(config)#mac-address-table aging-time 100
Console(config)#
```

show mac-address-table aging-time

This command shows the aging time for entries in the address table.

Default Setting

None

Command Mode

Privileged Exec

Example

```
Console#show mac-address-table aging-time
Aging time: 100 sec.
Console#
```

LLDP Commands

Link Layer Discovery Protocol (LLDP) is used to discover basic information about neighboring devices on the local broadcast domain. LLDP is a Layer 2 protocol that uses periodic broadcasts to advertise information about the sending device.

Advertised information is represented in Type Length Value (TLV) format according to the IEEE 802.1ab standard, and can include details such as device identification, capabilities and configuration settings. LLDP also defines how to store and maintain information gathered about the neighboring network nodes it discovers.

Link Layer Discovery Protocol - Media Endpoint Discovery (LLDP-MED) is an extension of LLDP intended for managing endpoint devices such as Voice over IP phones and network switches. The LLDP-MED TLVs advertise information such as network policy, power, inventory, and device location details. The LLDP and LLDP-MED information can be used by SNMP applications to simplify troubleshooting, enhance network management, and maintain an accurate network topology.

Table 4-11 LLDP Commands

Command	Function	Mode	Page
lldp	Enables LLDP globally on the switch	GC	4-195
lldp holdtime-multiplier	Configures the time-to-live (TTL) value sent in LLDP advertisements	GC	4-195
medFastStartCount	Configures how many medFastStart packets are transmitted	GC	4-196
lldp notification-interval	Configures the allowed interval for sending SNMP notifications about LLDP changes	GC	4-196
lldp refresh-interval	Configures the periodic transmit interval for LLDP advertisements	GC	4-197

Table 4-11 LLDP Commands (Continued)

Command	Function	Mode	Page
lldp reinit-delay	Configures the delay before attempting to re-initialize after LLDP ports are disabled or the link goes down	GC	4-198
lldp tx-delay	Configures a delay between the successive transmission of advertisements initiated by a change in local LLDP MIB variables	GC	4-198
lldp admin-status	Enables LLDP transmit, receive, or transmit and receive mode on the specified port	IC	4-199
lldp notification	Enables the transmission of SNMP trap notifications about LLDP changes	IC	4-199
lldp mednotification	Enables the transmission of SNMP trap notifications about LLDP-MED changes	IC	4-200
lldp basic-tlv management-ip-address	Configures an LLDP-enabled port to advertise the management address for this device	IC	4-201
lldp basic-tlv port-description	Configures an LLDP-enabled port to advertise its port description	IC	4-201
lldp basic-tlv system-capabilities	Configures an LLDP-enabled port to advertise its system capabilities	IC	4-202
lldp basic-tlv system-description	Configures an LLDP-enabled port to advertise the system description	IC	4-202
lldp basic-tlv system-name	Configures an LLDP-enabled port to advertise its system name	IC	4-203
lldp dot1-tlv proto-ident	Configures an LLDP-enabled port to advertise the supported protocols	IC	4-203
lldp dot1-tlv proto-vid	Configures an LLDP-enabled port to advertise port related VLAN information	IC	4-204
lldp dot1-tlv pvid	Configures an LLDP-enabled port to advertise its default VLAN ID	IC	4-204
lldp dot1-tlv vlan-name	Configures an LLDP-enabled port to advertise its VLAN name	IC	4-205
lldp dot3-tlv link-agg	Configures an LLDP-enabled port to advertise its link aggregation capabilities	IC	4-205
lldp dot3-tlv mac-phy	Configures an LLDP-enabled port to advertise its MAC and physical layer specifications	IC	4-206
lldp dot3-tlv max-frame	Configures an LLDP-enabled port to advertise its maximum frame size	IC	4-206
lldp dot3-tlv poe	Configures an LLDP-enabled port to advertise its Power-over-Ethernet capabilities	IC	4-207
lldp medtlv extpoe	Configures an LLDP-MED-enabled port to advertise its extended Power over Ethernet configuration and usage information	IC	4-207
lldp medtlv inventory	Configures an LLDP-MED-enabled port to advertise its inventory identification details	IC	4-208
lldp medtlv location	Configures an LLDP-MED-enabled port to advertise its location identification details	IC	4-208

Table 4-11 LLDP Commands (Continued)

Command	Function	Mode	Page
lldp medtlv med-cap	Configures an LLDP-MED-enabled port to advertise its Media Endpoint Device capabilities	IC	4-209
lldp medtlv network-policy	Configures an LLDP-MED-enabled port to advertise its network policy configuration	IC	4-209
show lldp config	Shows LLDP configuration settings for all ports	PE	4-210
show lldp info local-device	Shows LLDP global and interface-specific configuration settings for this device	PE	4-212
show lldp info remote-device	Shows LLDP global and interface-specific configuration settings for remote devices	PE	4-213
show lldp info statistics	Shows statistical counters for all LLDP-enabled interfaces	PE	4-213

lldp

This command enables LLDP globally on the switch. Use the **no** form to disable LLDP.

Syntax

[no] lldp

Default Setting

Enabled

Command Mode

Global Configuration

Example

```
Console (config) #lldp
Console (config) #
```

lldp holdtime-multiplier

This command configures the time-to-live (TTL) value sent in LLDP advertisements. Use the **no** form to restore the default setting.

Syntax

lldp holdtime-multiplier *value*

no lldp holdtime-multiplier

value - Calculates the TTL in seconds based on
(holdtime-multiplier * refresh-interval) ≤ 65536
(Range: 2 - 10)

Default Setting

Holdtime multiplier: 4
TTL: 4*30 = 120 seconds

Command Mode

Global Configuration

Command Usage

The time-to-live tells the receiving LLDP agent how long to retain all information pertaining to the sending LLDP agent if it does not transmit updates in a timely manner.

Example

```
Console(config)#lldp holdtime-multiplier 10
Console(config)#
```

lldp medFastStartCount

This command specifies the amount of MED Fast Start LLDPDUs to transmit during the activation process of the LLDP-MED Fast Start mechanism.

Syntax

lldp medfaststartcount *packets*

seconds - Amount of packets. (Range: 1-10 packets; Default: 4 packets)

Default Setting

4 packets

Command Mode

Global Configuration

Command Usage

The MEDFastStartCount parameter is part of the timer which ensures that the LLDP-MED Fast Start mechanism is active for the port. LLDP-MED Fast Start is critical to the timely startup of LLDP, and therefore integral to the rapid availability of Emergency Call Service.

Example

```
Console(config)#lldp medfaststartcount 6
Console(config)#
```

lldp notification-interval

This command configures the allowed interval for sending SNMP notifications about LLDP MIB changes. Use the **no** form to restore the default setting.

Syntax

lldp notification-interval *seconds*

no lldp notification-interval

seconds - Specifies the periodic interval at which SNMP notifications are sent. (Range: 5 - 3600 seconds)

4 Command Line Interface

Default Setting

5 seconds

Command Mode

Global Configuration

Command Usage

- This parameter only applies to SNMP applications which use data stored in the LLDP MIB for network monitoring or management.
- Information about changes in LLDP neighbors that occur between SNMP notifications is not transmitted. Only state changes that exist at the time of a notification are included in the transmission. An SNMP agent should therefore periodically check the value of `IldpStatsRemTableLastChangeTime` to detect any `IldpRemTablesChange` notification-events missed due to throttling or transmission loss.

Example

```
Console(config)#lldp notification-interval 30
Console(config)#
```

lldp refresh-interval

This command configures the periodic transmit interval for LLDP advertisements. Use the **no** form to restore the default setting.

Syntax

lldp refresh-interval *seconds*
no lldp refresh-delay

seconds - Specifies the periodic interval at which LLDP advertisements are sent. (Range: 5 - 32768 seconds)

Default Setting

30 seconds

Command Mode

Global Configuration

Command Usage

This attribute must comply with the following rule:
(refresh-interval * holdtime-multiplier) ≤ 65536

Example

```
Console(config)#lldp refresh-interval 60
Console(config)#
```

lldp reinit-delay

This command configures the delay before attempting to re-initialize after LLDP ports are disabled or the link goes down. Use the **no** form to restore the default setting.

Syntax

lldp reinit-delay *seconds*
no lldp reinit-delay

seconds - Specifies the delay before attempting to re-initialize LLDP.
(Range: 1 - 10 seconds)

Default Setting

2 seconds

Command Mode

Global Configuration

Command Usage

When LLDP is re-initialized on a port, all information in the remote systems LLDP MIB associated with this port is deleted.

Example

```
Console(config)#lldp reinit-delay 10  
Console(config)#
```

lldp tx-delay

This command configures a delay between the successive transmission of advertisements initiated by a change in local LLDP MIB variables. Use the **no** form to restore the default setting.

Syntax

lldp tx-delay *seconds*
no lldp tx-delay

seconds - Specifies the transmit delay. (Range: 1 - 8192 seconds)

Default Setting

2 seconds

Command Mode

Global Configuration

Command Usage

- The transmit delay is used to prevent a series of successive LLDP transmissions during a short period of rapid changes in local LLDP MIB objects, and to increase the probability that multiple, rather than single changes, are reported in each transmission.

4 Command Line Interface

- This attribute must comply with the following rule:
 $(4 * \text{tx-delay}) \leq \text{refresh-interval}$

Example

```
Console(config)#lldp tx-delay 10
Console(config)#
```

lldp admin-status

This command enables LLDP transmit, receive, or transmit and receive mode on the specified port. Use the **no** form to disable this feature.

Syntax

```
lldp admin-status {rx-only | tx-only | tx-rx}
no lldp admin-status
```

- **rx-only** - Only receive LLDP PDUs.
- **tx-only** - Only transmit LLDP PDUs.
- **tx-rx** - Both transmit and receive LLDP Protocol Data Units (PDUs).

Default Setting

tx-rx

Command Mode

Interface Configuration (Ethernet, Port Channel)

Example

```
Console(config)#interface ethernet 1/1
Console(config-if)#lldp admin-status rx-only
Console(config-if)#
```

lldp notification

This command enables the transmission of SNMP trap notifications about LLDP changes. Use the **no** form to disable LLDP notifications.

Syntax

```
[no] lldp notification
```

Default Setting

Enabled

Command Mode

Interface Configuration (Ethernet, Port Channel)

Command Usage

- This option sends out SNMP trap notifications to designated target stations at the interval specified by the **lldp notification-interval** command (page 4-196). Trap notifications include information about state changes in

the LLDP MIB (IEEE 802.1AB), or organization-specific LLDP-EXT-DOT1 and LLDP-EXT-DOT3 MIBs.

- SNMP trap destinations are defined using the **snmp-server host** command (page 4-153).
- Information about additional changes in LLDP neighbors that occur between SNMP notifications is not transmitted. Only state changes that exist at the time of a trap notification are included in the transmission. An SNMP agent should therefore periodically check the value of `IldpStatsRemTableLastChangeTime` to detect any `IldpRemTablesChange` notification-events missed due to throttling or transmission loss.

Example

```
Console(config)#interface ethernet 1/1
Console(config-if)#lldp notification
Console(config-if)#
```

Ildp mednotification

This command enables the transmission of SNMP trap notifications about LLDP-MED changes. Use the **no** form to disable LLDP-MED notifications.

Syntax

[no] **lldp mednotification**

Default Setting

Enabled

Command Mode

Interface Configuration (Ethernet, Port Channel)

Command Usage

- This option sends out SNMP trap notifications to designated target stations at the interval specified by the **lldp notification-interval** command (page 4-196). Trap notifications include information about state changes in the LLDP MIB (IEEE 802.1AB), the LLDP-MED MIB (ANSI/TIA 1057), or organization-specific LLDP-EXT-DOT1 and LLDP-EXT-DOT3 MIBs.
- SNMP trap destinations are defined using the **snmp-server host** command (page 4-153).
- Information about additional changes in LLDP neighbors that occur between SNMP notifications is not transmitted. Only state changes that exist at the time of a trap notification are included in the transmission. An SNMP agent should therefore periodically check the value of `IldpStatsRemTableLastChangeTime` to detect any `IldpRemTablesChange` notification-events missed due to throttling or transmission loss.

Example

```
Console(config)#interface ethernet 1/1
Console(config-if)#lldp mednotification
Console(config-if)#
```

lldp basic-tlv management-ip-address

This command configures an LLDP-enabled port to advertise the management address for this device. Use the **no** form to disable this feature.

Syntax

[no] **lldp basic-tlv management-ip-address**

Default Setting

Enabled

Command Mode

Interface Configuration (Ethernet, Port Channel)

Command Usage

- The management address protocol packet includes the IPv4 address of the switch. If no management address is available, the address should be the MAC address for the CPU or for the port sending this advertisement.
- The management address TLV may also include information about the specific interface associated with this address, and an object identifier indicating the type of hardware component or protocol entity associated with this address. The interface number and OID are included to assist SNMP applications to perform network discovery by indicating enterprise specific or other starting points for the search, such as the Interface or Entity MIB.
- Since there are typically a number of different addresses associated with a Layer 3 device, an individual LLDP PDU may contain more than one management address TLV.
- Every management address TLV that reports an address that is accessible on a port and protocol VLAN through the particular port should be accompanied by a port and protocol VLAN TLV that indicates the VLAN identifier (VID) associated with the management address reported by this TLV.

Example

```
Console(config)#interface ethernet 1/1
Console(config-if)#lldp basic-tlv management-ip-address
Console(config-if)#
```

lldp basic-tlv port-description

This command configures an LLDP-enabled port to advertise its port description. Use the **no** form to disable this feature.

Syntax

[no] lldp basic-tlv port-description

Default Setting

Enabled

Command Mode

Interface Configuration (Ethernet, Port Channel)

Command Usage

The port description is taken from the ifDescr object in RFC 2863, which includes information about the manufacturer, the product name, and the version of the interface hardware/software.

Example

```
Console(config)#interface ethernet 1/1
Console(config-if)#lldp basic-tlv port-description
Console(config-if)#
```

lldp basic-tlv system-capabilities

This command configures an LLDP-enabled port to advertise its system capabilities. Use the **no** form to disable this feature.

Syntax

[no] lldp basic-tlv system-capabilities

Default Setting

Enabled

Command Mode

Interface Configuration (Ethernet, Port Channel)

Command Usage

The system capabilities identifies the primary function(s) of the system and whether or not these primary functions are enabled. The information advertised by this TLV is described in IEEE 802.1AB.

Example

```
Console(config)#interface ethernet 1/1
Console(config-if)#lldp basic-tlv system-capabilities
Console(config-if)#
```

lldp basic-tlv system-description

This command configures an LLDP-enabled port to advertise the system description. Use the **no** form to disable this feature.

4 Command Line Interface

Syntax

[no] **lldp basic-tlv system-description**

Default Setting

Enabled

Command Mode

Interface Configuration (Ethernet, Port Channel)

Command Usage

The system description is taken from the sysDescr object in RFC 3418, which includes the full name and version identification of the system's hardware type, software operating system, and networking software.

Example

```
Console(config)#interface ethernet 1/1
Console(config-if)#lldp basic-tlv system-description
Console(config-if)#
```

lldp basic-tlv system-name

This command configures an LLDP-enabled port to advertise the system name. Use the **no** form to disable this feature.

Syntax

[no] **lldp basic-tlv system-name**

Default Setting

Enabled

Command Mode

Interface Configuration (Ethernet, Port Channel)

Command Usage

The system name is taken from the sysName object in RFC 3418, which contains the system's administratively assigned name, and is in turn based on the **hostname** command (page 4-27).

Example

```
Console(config)#interface ethernet 1/1
Console(config-if)#lldp basic-tlv system-name
Console(config-if)#
```

lldp dot1-tlv proto-ident

This command configures an LLDP-enabled port to advertise the supported protocols. Use the **no** form to disable this feature.

Syntax

[no] lldp dot1-tlv proto-ident

Default Setting

Enabled

Command Mode

Interface Configuration (Ethernet, Port Channel)

Command Usage

This option advertises the protocols that are accessible through this interface.

Example

```
Console(config)#interface ethernet 1/1
Console(config-if)#no lldp dot1-tlv proto-ident
Console(config-if)#
```

lldp dot1-tlv proto-vid

This command configures an LLDP-enabled port to advertise port related VLAN information. Use the **no** form to disable this feature.

Syntax

[no] lldp dot1-tlv proto-vid

Default Setting

Enabled

Command Mode

Interface Configuration (Ethernet, Port Channel)

Command Usage

This option advertises the port-based and protocol-based VLANs configured on this interface (see “Configuring VLAN Interfaces” on page 4-244 and “Configuring Protocol-based VLANs” on page 4-261).

Example

```
Console(config)#interface ethernet 1/1
Console(config-if)#no lldp dot1-tlv proto-vid
Console(config-if)#
```

lldp dot1-tlv pvid

This command configures an LLDP-enabled port to advertise its default VLAN ID. Use the **no** form to disable this feature.

Syntax

[no] lldp dot1-tlv pvid

Default Setting

Enabled

Command Mode

Interface Configuration (Ethernet, Port Channel)

Command Usage

The port's default VLAN identifier (PVID) indicates the VLAN with which untagged or priority-tagged frames are associated (see “switchport native vlan” on page 4-247).

Example

```
Console(config)#interface ethernet 1/1
Console(config-if)#no lldp dot1-tlv pvid
Console(config-if)#
```

lldp dot1-tlv vlan-name

This command configures an LLDP-enabled port to advertise its VLAN name. Use the **no** form to disable this feature.

Syntax

[no] lldp dot1-tlv vlan-name

Default Setting

Enabled

Command Mode

Interface Configuration (Ethernet, Port Channel)

Command Usage

This option advertises the name of all VLANs to which this interface has been assigned. See “switchport allowed vlan” on page 4-248 and “protocol-vlan protocol-group (Configuring VLANs)” on page 4-262.

Example

```
Console(config)#interface ethernet 1/1
Console(config-if)#no lldp dot1-tlv vlan-name
Console(config-if)#
```

lldp dot3-tlv link-agg

This command configures an LLDP-enabled port to advertise link aggregation capabilities. Use the **no** form to disable this feature.

Syntax

[no] lldp dot3-tlv link-agg

Default Setting

Enabled

Command Mode

Interface Configuration (Ethernet, Port Channel)

Command Usage

This option advertises link aggregation capabilities, aggregation status of the link, and the 802.3 aggregated port identifier if this interface is currently a link aggregation member.

Example

```
Console(config)#interface ethernet 1/1
Console(config-if)#no lldp dot3-tlv link-agg
Console(config-if)#
```

lldp dot3-tlv mac-phy

This command configures an LLDP-enabled port to advertise its MAC and physical layer capabilities. Use the **no** form to disable this feature.

Syntax

[no] lldp dot3-tlv mac-phy

Default Setting

Enabled

Command Mode

Interface Configuration (Ethernet, Port Channel)

Command Usage

This option advertises MAC/PHY configuration/status which includes information about auto-negotiation support/capabilities, and operational Multistation Access Unit (MAU) type.

Example

```
Console(config)#interface ethernet 1/1
Console(config-if)#no lldp dot3-tlv mac-phy
Console(config-if)#
```

lldp dot3-tlv max-frame

This command configures an LLDP-enabled port to advertise its maximum frame size. Use the **no** form to disable this feature.

Syntax

[no] lldp dot3-tlv max-frame

4 Command Line Interface

Default Setting

Enabled

Command Mode

Interface Configuration (Ethernet, Port Channel)

Command Usage

Refer to “Frame Size Commands” on page 4-83 for information on configuring the maximum frame size for this switch.

Example

```
Console(config)#interface ethernet 1/1
Console(config-if)#lldp dot3-tlv max-frame
Console(config-if)#
```

lldp dot3-tlv poe

This command configures an LLDP-enabled port to advertise its Power-over-Ethernet (PoE) capabilities. Use the **no** form to disable this feature.

Syntax

[no] lldp dot3-tlv poe

Default Setting

Enabled

Command Mode

Interface Configuration (Ethernet, Port Channel)

Command Usage

This option advertises Power-over-Ethernet capabilities, including whether or not PoE is supported, currently enabled, if the port pins through which power is delivered can be controlled, the port pins selected to deliver power, and the power class. Note that this device does not support PoE capabilities.

Example

```
Console(config)#interface ethernet 1/1
Console(config-if)#lldp dot3-tlv poe
Console(config-if)#
```

lldp medtlv extpoe

This command configures an LLDP-MED-enabled port to advertise and accept Extended Power-over-Ethernet configuration and usage information. Use the **no** form to disable this feature.

Syntax

[no] lldp medtlv extpoe

Default Setting

Enabled

Command Mode

Interface Configuration (Ethernet, Port Channel)

Command Usage

This option advertises extended Power-over-Ethernet capability details, such as power availability from the switch, and power state of the switch, including whether the switch is operating from primary or backup power (the Endpoint Device could use this information to decide to enter power conservation mode). Note that this device does not support PoE capabilities.

Example

```
Console(config)#interface ethernet 1/1
Console(config-if)#no lldp medtlv extpoe
Console(config-if)#
```

lldp medtlv inventory

This command configures an LLDP-MED-enabled port to advertise its inventory identification details. Use the **no** form to disable this feature.

Syntax

[no] lldp medtlv inventory

Default Setting

Enabled

Command Mode

Interface Configuration (Ethernet, Port Channel)

Command Usage

This option advertises device details useful for inventory management, such as manufacturer, model, software version and other pertinent information.

Example

```
Console(config)#interface ethernet 1/1
Console(config-if)#no lldp medtlv inventory
Console(config-if)#
```

lldp medtlv location

This command configures an LLDP-MED-enabled port to advertise its location identification details. Use the **no** form to disable this feature.

Syntax

[no] lldp medtlv location

4 Command Line Interface

Default Setting

Enabled

Command Mode

Interface Configuration (Ethernet, Port Channel)

Command Usage

This option advertises location identification details.

Example

```
Console(config)#interface ethernet 1/1
Console(config-if)#lldp medtlv location
Console(config-if)#
```

lldp medtlv med-cap

This command configures an LLDP-MED-enabled port to advertise its Media Endpoint Device capabilities. Use the **no** form to disable this feature.

Syntax

[no] **lldp medtlv med-cap**

Default Setting

Enabled

Command Mode

Interface Configuration (Ethernet, Port Channel)

Command Usage

This option advertises LLDP-MED TLV capabilities, allowing Media Endpoint and Connectivity Devices to efficiently discover which LLDP-MED related TLVs are supported on the switch.

Example

```
Console(config)#interface ethernet 1/1
Console(config-if)#lldp medtlv med-cap
Console(config-if)#
```

lldp medtlv network-policy

This command configures an LLDP-MED-enabled port to advertise its network policy configuration. Use the **no** form to disable this feature.

Syntax

[no] **lldp medtlv network-policy**

Default Setting

Enabled

Command Mode

Interface Configuration (Ethernet, Port Channel)

Command Usage

This option advertises network policy configuration information, aiding in the discovery and diagnosis of VLAN configuration mismatches on a port. Improper network policy configurations frequently result in voice quality degradation or complete service disruption.

Example

```
Console(config)#interface ethernet 1/1
Console(config-if)#lldp medtlv network-policy
Console(config-if)#
```

show lldp config

This command shows LLDP configuration settings for all ports.

Syntax

show lldp config [**detail** *interface*]

- **detail** - Shows configuration summary.
- *interface*
 - **ethernet** *unit/port*
 - *unit* - Stack unit. (Range: 1)
 - *port* - Port number. (Range: 1-28/52)
 - **port-channel** *channel-id* (Range: 1-8)

Command Mode

Privileged Exec

Example

```
Console#show lldp config

LLDP Global Configuration

LLDP Enable           : Yes
LLDP Transmit interval : 30
LLDP Hold Time Multiplier : 4
LLDP Delay Interval   : 2
LLDP Reinit Delay     : 2
LLDP Notification Interval : 5
LLDP MED fast start counts : 4

LLDP Port Configuration

Interface |AdminStatus NotificationEnabled
-----+-----
Eth 1/1  | Tx-Rx      True
Eth 1/2  | Tx-Rx      True
Eth 1/3  | Tx-Rx      True
Eth 1/4  | Tx-Rx      True
Eth 1/5  | Tx-Rx      True
:
:
Console#show lldp config detail ethernet 1/1

LLDP Port Configuration Detail

Port : Eth 1/1
Admin Status : Tx-Rx
Notification Enabled : True
Basic TLVs Advertised:
  port-description
  system-name
  system-description
  system-capabilities
  management-ip-address
802.1 specific TLVs Advertised:
  *port-vid
  *vlan-name
  *proto-vlan
  *proto-ident
802.3 specific TLVs Advertised:
  *mac-phy
  *poe
  *link-agg
  *max-frame
MED Configuration:
MED Notification Enabled : True MED Enabled TLVs Advertised:
  *med-cap
  *network-policy
  *location
  *extPoe
  *inventory

Console#
```

show lldp info local-device

This command shows LLDP global and interface-specific configuration settings for this device.

Syntax

show lldp info local-device [detail interface]

- **detail** - Shows detailed information.
- **interface**
 - **ethernet unit/port**
 - *unit* - Stack unit. (Range: 1)
 - *port* - Port number. (Range: 1-28/52)
 - **port-channel channel-id** (Range: 1-8)

Command Mode

Privileged Exec

Example

```

Console#show lldp info local-device

LLDP Local System Information
Chassis Type : MAC Address
Chassis ID   : 00-01-02-03-04-05
System Name  :
System Description : TL-SL5428
System Capabilities Support : Bridge
System Capabilities Enable : Bridge
Management Address : 192.168.0.101 (IPv4)

LLDP Port Information
Interface |PortID Type      PortID      PortDesc
-----+-----
Eth 1/1  |MAC Address     00-01-02-03-04-06 Ethernet Port on unit 1, port 1
Eth 1/2  |MAC Address     00-01-02-03-04-07 Ethernet Port on unit 1, port 2
Eth 1/3  |MAC Address     00-01-02-03-04-08 Ethernet Port on unit 1, port 3
Eth 1/4  |MAC Address     00-01-02-03-04-09 Ethernet Port on unit 1, port 4
:
:
Console#show lldp info local-device detail ethernet 1/1

LLDP Port Information Detail

Port      : Eth 1/1
Port Type : MAC Address
Port ID   : 00-01-02-03-04-06
Port Desc : Ethernet Port on unit 1, port 1

Console#

```

show lldp info remote-device

This command shows LLDP global and interface-specific configuration settings for remote devices attached to an LLDP-enabled port.

Syntax

show lldp info remote-device [**detail** *interface*]

- **detail** - Shows detailed information.
- **interface**
 - **ethernet** *unit/port*
 - *unit* - Stack unit. (Range: 1)
 - *port* - Port number. (Range: 1-28/52)
 - **port-channel** *channel-id* (Range: 1-8)

Command Mode

Privileged Exec

Example

```
Console#show lldp info remote-device

LLDP Remote Devices Information

  Interface | ChassisId           PortId           SysName
  ----- + -----
  Eth 1/1   | 00-01-02-03-04-05  00-01-02-03-04-06

Console#show lldp info remote-device detail ethernet 1/1

LLDP Remote Devices Information Detail

-----
Local PortName      : Eth 1/1
Chassis Type        : MAC Address
Chassis Id          : 00-01-02-03-04-05
PortID Type         : MAC Address
PortID              : 00-01-02-03-04-06
SysName             :
SysDescr            : TL-SL5428
PortDescr           : Ethernet Port on unit 1, port 1
SystemCapSupported  : Bridge
SystemCapEnabled    : Bridge
Remote Management Address :
    00-01-02-03-04-05 (MAC Address)

Console#
```

show lldp info statistics

This command shows statistics based on traffic received through all attached LLDP-enabled interfaces.

Syntax

show lldp info statistics [**detail** *interface*]

- **detail** - Shows detailed information.
- **interface**
 - **ethernet unit/port**
 - *unit* - Stack unit. (Range: 1)
 - *port* - Port number. (Range: 1-28/52)
 - **port-channel channel-id** (Range: 1-8)

Command Mode

Privileged Exec

Example

```
switch#show lldp info statistics

LLDP Device Statistics

Neighbor Entries List Last Updated : 2450279 seconds
New Neighbor Entries Count         : 1
Neighbor Entries Deleted Count     : 0
Neighbor Entries Dropped Count     : 0
Neighbor Entries Ageout Count      : 0

Interface | NumFramesRecvd NumFramesSent NumFramesDiscarded
-----+-----+-----+-----
Eth 1/1   | 10             11             0
Eth 1/2   | 0              0              0
Eth 1/3   | 0              0              0
Eth 1/4   | 0              0              0
Eth 1/5   | 0              0              0
:
switch#show lldp info statistics detail ethernet 1/1

LLDP Port Statistics Detail

PortName      : Eth 1/1
Frames Discarded : 0
Frames Invalid : 0
Frames Received : 12
Frames Sent    : 13
TLVs Unrecognized : 0
TLVs Discarded : 0
Neighbor Ageouts : 0

switch#
```

UPnP Commands

Universal Plug and Play (UPnP) is a set of protocols that allows devices to connect seamlessly and simplifies the deployment of home and office networks. UPnP achieves this by issuing UPnP device control protocols designed upon open, Internet-based communication standards.

Table 4-1. UPnP Commands

Command	Function	Mode	Page
upnp device	Enables/disables UPnP on the network	GC	4-215
upnp device ttl	Sets the time-to-live (TTL) value.	GC	4-216
upnp device advertise duration	Sets the advertisement duration of the device	GC	4-216
show upnp	Displays UPnP status and parameters	PE	4-217

upnp device

This command enables UPnP on the device. Use the **no** form to disable UPnP.

Syntax

```
[no] upnp device}
```

Default Setting

Enabled

Command Mode

Global Configuration

Command Usage

You must enable UPnP before you can configure time out settings for sending of UPnP messages.

Example

In the following example, UPnP is enabled on the device.

```
Console(config)#upnp device
Console(config)#
```

Related Commands

upnp device ttl (4-216)
upnp device advertise duration (4-216)

upnp device ttl

This command sets the time-to-live (TTL) value for sending of UPnP messages from the device.

Syntax

upnp device ttl {*value*}

- *value* - The number of router hops a UPnP packet can travel before it is discarded. (Range:1-255)

Default Setting

4

Command Mode

Global Configuration

Command Usage

UPnP devices and control points must be within the local network, that is within the TTL value for multicast messages.

Example

In the following example, the TTL is set to 6.

```
Console(config)#upnp device ttl 6
Console(config)#
```

upnp device advertise duration

This command sets the duration for which a device will advertise its presence on the local network.

Syntax

upnp device advertise duration {*value*}

- *value* - A time out value expressed in seconds. (Range: 6-86400 seconds)

Default Setting

100 seconds

Command Mode

Global Configuration

Example

In the following example, the device advertise duration is set to 200 seconds.

```
Console(config)#upnp device advertise duration 200
Console(config)#
```

Related Commands

upnp device ttl (4-216)

show upnp

This command displays the UPnP management status and time out settings.

Command Mode

Privileged Exec

Example

```
Console#show upnp
UPnP global settings:
  Status:           Enabled
  Advertise duration: 200
  TTL:             20
Console#
```

Spanning Tree Commands

This section includes commands that configure the Spanning Tree Algorithm (STA) globally for the switch, and commands that configure STA for the selected interface.

Table 4-12 Spanning Tree Commands

Command	Function	Mode	Page
spanning-tree	Enables the spanning tree protocol	GC	4-218
spanning-tree mode	Configures STP, RSTP or MSTP mode	GC	4-219
spanning-tree forward-time	Configures the spanning tree bridge forward time	GC	4-220
spanning-tree hello-time	Configures the spanning tree bridge hello time	GC	4-221
spanning-tree max-age	Configures the spanning tree bridge maximum age	GC	4-221
spanning-tree priority	Configures the spanning tree bridge priority	GC	4-222
spanning-tree path-cost method	Configures the path cost method for RSTP/MSTP	GC	4-222
spanning-tree transmission-limit	Configures the transmission limit for RSTP/MSTP	GC	4-223
spanning-tree mst-configuration	Changes to MSTP configuration mode	GC	4-223
mst vlan	Adds VLANs to a spanning tree instance	MST	4-224
mst priority	Configures the priority of a spanning tree instance	MST	4-225
name	Configures the name for the multiple spanning tree	MST	4-225
revision	Configures the revision number for the multiple spanning tree	MST	4-226
max-hops	Configures the maximum number of hops allowed in the region before a BPDU is discarded	MST	4-226

Table 4-12 Spanning Tree Commands (Continued)

Command	Function	Mode	Page
spanning-tree spanning-disabled	Disables spanning tree for an interface	IC	4-227
spanning-tree cost	Configures the spanning tree path cost of an interface	IC	4-227
spanning-tree port-priority	Configures the spanning tree priority of an interface	IC	4-228
spanning-tree edge-port	Enables fast forwarding for edge ports	IC	4-229
spanning-tree portfast	Sets an interface to fast forwarding	IC	4-230
spanning-tree link-type	Configures the link type for RSTP/MSTP	IC	4-231
spanning-tree loopback-detection	Enables BPDU loopback detection for the port	IC	4-231
spanning-tree loopback-detection release-mode	Configures loopback release mode for the port	IC	4-232
spanning-tree loopback-detection trap	Enables BPDU loopback SNMP trap notification for the port	IC	4-233
spanning-tree mst cost	Configures the path cost of an instance in the MST	IC	4-233
spanning-tree mst port-priority	Configures the priority of an instance in the MST	IC	4-234
spanning-tree protocol-migration	Re-checks the appropriate BPDU format	PE	4-235
show spanning-tree	Shows spanning tree configuration for the common spanning tree (i.e., overall bridge), a selected interface, or an instance within the multiple spanning tree	PE	4-235
show spanning-tree mst configuration	Shows the multiple spanning tree configuration	PE	4-237

spanning-tree

This command enables the Spanning Tree Algorithm globally for the switch. Use the **no** form to disable it.

Syntax

[no] **spanning-tree**

Default Setting

Spanning tree is enabled.

Command Mode

Global Configuration

Command Usage

The Spanning Tree Algorithm (STA) can be used to detect and disable network loops, and to provide backup links between switches, bridges or routers. This allows the switch to interact with other bridging devices (that is,

an STA-compliant switch, bridge or router) in your network to ensure that only one route exists between any two stations on the network, and provide backup links which automatically take over when a primary link goes down.

Example

This example shows how to enable the Spanning Tree Algorithm for the switch:

```
Console(config)#spanning-tree
Console(config)#
```

spanning-tree mode

This command selects the spanning tree mode for this switch. Use the **no** form to restore the default.

Note: MSTP is not supported in the current software.

Syntax

```
spanning-tree mode {stp | rstp | mstp}
no spanning-tree mode
```

- **stp** - Spanning Tree Protocol (IEEE 802.1D)
- **rstp** - Rapid Spanning Tree Protocol (IEEE 802.1w)
- **mstp** - Multiple Spanning Tree (IEEE 802.1s)

Default Setting

rstp

Command Mode

Global Configuration

Command Usage

- Spanning Tree Protocol
 - Uses RSTP for the internal state machine, but sends only 802.1D BPDUs.
 - This creates one spanning tree instance for the entire network. If multiple VLANs are implemented on a network, the path between specific VLAN members may be inadvertently disabled to prevent network loops, thus isolating group members. When operating multiple VLANs, we recommend selecting the MSTP option.
- Rapid Spanning Tree Protocol
 - RSTP supports connections to either STP or RSTP nodes by monitoring the incoming protocol messages and dynamically adjusting the type of protocol messages the RSTP node transmits, as described below:
 - STP Mode – If the switch receives an 802.1D BPDU after a port's migration delay timer expires, the switch assumes it is connected to an 802.1D bridge and starts using only 802.1D BPDUs.
 - RSTP Mode – If RSTP is using 802.1D BPDUs on a port and receives an RSTP BPDU after the migration delay expires, RSTP restarts the migration delay timer and begins using RSTP BPDUs on that port.

- Multiple Spanning Tree Protocol
 - To allow multiple spanning trees to operate over the network, you must configure a related set of bridges with the same MSTP configuration, allowing them to participate in a specific set of spanning tree instances.
 - A spanning tree instance can exist only on bridges that have compatible VLAN instance assignments.
 - Be careful when switching between spanning tree modes. Changing modes stops all spanning-tree instances for the previous mode and restarts the system in the new mode, temporarily disrupting user traffic.

Example

The following example configures the switch to use Rapid Spanning Tree:

```
Console(config)#spanning-tree mode rstp
Console(config)#
```

spanning-tree forward-time

This command configures the spanning tree bridge forward time globally for this switch. Use the **no** form to restore the default.

Syntax

spanning-tree forward-time *seconds*
no spanning-tree **forward-time**

seconds - Time in seconds. (Range: 4 - 30 seconds)

The minimum value is the higher of 4 or $[(\text{max-age} / 2) + 1]$.

Default Setting

15 seconds

Command Mode

Global Configuration

Command Usage

This command sets the maximum time (in seconds) the root device will wait before changing states (i.e., discarding to learning to forwarding). This delay is required because every device must receive information about topology changes before it starts to forward frames. In addition, each port needs time to listen for conflicting information that would make it return to the discarding state; otherwise, temporary data loops might result.

Example

```
Console(config)#spanning-tree forward-time 20
Console(config)#
```

spanning-tree hello-time

This command configures the spanning tree bridge hello time globally for this switch. Use the **no** form to restore the default.

Syntax

spanning-tree hello-time *time*
no spanning-tree hello-time

time - Time in seconds. (Range: 1-10 seconds).

The maximum value is the lower of 10 or $[(\text{max-age} / 2) - 1]$.

Default Setting

2 seconds

Command Mode

Global Configuration

Command Usage

This command sets the time interval (in seconds) at which the root device transmits a configuration message.

Example

```
Console(config)#spanning-tree hello-time 5
Console(config)#
```

Related Commands

spanning-tree forward-time (4-220)

spanning-tree max-age (4-221)

spanning-tree max-age

This command configures the spanning tree bridge maximum age globally for this switch. Use the **no** form to restore the default.

Syntax

spanning-tree max-age *seconds*
no spanning-tree max-age

seconds - Time in seconds. (Range: 6-40 seconds)

The minimum value is the higher of 6 or $[2 \times (\text{hello-time} + 1)]$.

The maximum value is the lower of 40 or $[2 \times (\text{forward-time} - 1)]$.

Default Setting

20 seconds

Command Mode

Global Configuration

Command Usage

This command sets the maximum time (in seconds) a device can wait without receiving a configuration message before attempting to reconfigure. All device

ports (except for designated ports) should receive configuration messages at regular intervals. Any port that ages out STA information (provided in the last configuration message) becomes the designated port for the attached LAN. If it is a root port, a new root port is selected from among the device ports attached to the network.

Example

```
Console(config)#spanning-tree max-age 40
Console(config)#
```

Related Commands

spanning-tree forward-time (4-220)
spanning-tree hello-time (4-221)

spanning-tree priority

This command configures the spanning tree priority globally for this switch. Use the **no** form to restore the default.

Syntax

spanning-tree priority *priority*
no spanning-tree priority

priority - Priority of the bridge. (Range: 0 - 65535)
(Range – 0-61440, in steps of 4096; Options: 0, 4096, 8192, 12288, 16384, 20480, 24576, 28672, 32768, 36864, 40960, 45056, 49152, 53248, 57344, 61440)

Default Setting

32768

Command Mode

Global Configuration

Command Usage

Bridge priority is used in selecting the root device, root port, and designated port. The device with the highest priority (i.e., lower numeric value) becomes the STA root device. However, if all devices have the same priority, the device with the lowest MAC address will then become the root device.

Example

```
Console(config)#spanning-tree priority 40000
Console(config)#
```

spanning-tree pathcost method

This command configures the path cost method used for Rapid Spanning Tree and Multiple Spanning Tree. Use the **no** form to restore the default.

Syntax

spanning-tree pathcost method {long | short}

no spanning-tree pathcost method

- **long** - Specifies 32-bit based values that range from 1-200,000,000. This method is based on the IEEE 802.1w Rapid Spanning Tree Protocol.
- **short** - Specifies 16-bit based values that range from 1-65535. This method is based on the IEEE 802.1 Spanning Tree Protocol.

Default Setting

Long method

Command Mode

Global Configuration

Command Usage

The path cost method is used to determine the best path between devices. Therefore, lower values should be assigned to ports attached to faster media, and higher values assigned to ports with slower media. Note that path cost (page 4-227) takes precedence over port priority (page 4-228).

Example

```
Console(config)#spanning-tree pathcost method long
Console(config)#
```

spanning-tree transmission-limit

This command configures the minimum interval between the transmission of consecutive RSTP/MSTP BPDUs. Use the **no** form to restore the default.

Syntax

spanning-tree transmission-limit *count*
no spanning-tree transmission-limit

count - The transmission limit in seconds. (Range: 1-10)

Default Setting

3

Command Mode

Global Configuration

Command Usage

This command limits the maximum transmission rate for BPDUs.

Example

```
Console(config)#spanning-tree transmission-limit 4
Console(config)#
```

spanning-tree mst-configuration

This command changes to Multiple Spanning Tree (MST) configuration mode.

Default Setting

- No VLANs are mapped to any MST instance.
- The region name is set the switch's MAC address.

Command Mode

Global Configuration

Example

```
Console(config)#spanning-tree mst configuration
Console(config-mstp)#
```

Related Commands

mst vlan (4-224)
mst priority (4-225)
name (4-225)
revision (4-226)
max-hops (4-226)

mst vlan

This command adds VLANs to a spanning tree instance. Use the **no** form to remove the specified VLANs. Using the **no** form without any VLAN parameters to remove all VLANs.

Syntax

[no] mst *instance_id* vlan *vlan-range*

- *instance_id* - Instance identifier of the spanning tree. (Range: 0-4094)
- *vlan-range* - Range of VLANs. (Range: 1-4092)

Default Setting

none

Command Mode

MST Configuration

Command Usage

- Use this command to group VLANs into spanning tree instances. MSTP generates a unique spanning tree for each instance. This provides multiple pathways across the network, thereby balancing the traffic load, preventing wide-scale disruption when a bridge node in a single instance fails, and allowing for faster convergence of a new topology for the failed instance.
- By default all VLANs are assigned to the Internal Spanning Tree (MSTI 0) that connects all bridges and LANs within the MST region. This switch supports up to 58 instances. You should try to group VLANs which cover the same general area of your network. However, remember that you must configure all bridges within the same MSTI Region (page 4-225) with the same set of instances, and the same instance (on each bridge) with the same set of VLANs. Also, note that RSTP treats each MSTI region as a single node, connecting all regions to the Common Spanning Tree.

Example

```
Console(config-mstp)#mst 1 vlan 2-5
Console(config-mstp)#
```

mst priority

This command configures the priority of a spanning tree instance. Use the **no** form to restore the default.

Syntax

mst *instance_id* **priority** *priority*

no mst *instance_id* **priority**

- *instance_id* - Instance identifier of the spanning tree. (Range: 0-4094)
- *priority* - Priority of the a spanning tree instance.
(Range: 0-61440 in steps of 4096; Options: 0, 4096, 8192, 12288, 16384, 20480, 24576, 28672, 32768, 36864, 40960, 45056, 49152, 53248, 57344, 61440)

Default Setting

32768

Command Mode

MST Configuration

Command Usage

- MST priority is used in selecting the root bridge and alternate bridge of the specified instance. The device with the highest priority (i.e., lowest numerical value) becomes the MSTI root device. However, if all devices have the same priority, the device with the lowest MAC address will then become the root device.
- You can set this switch to act as the MSTI root device by specifying a priority of 0, or as the MSTI alternate device by specifying a priority of 16384.

Example

```
Console(config-mstp)#mst 1 priority 4096
Console(config-mstp)#
```

name

This command configures the name for the multiple spanning tree region in which this switch is located. Use the **no** form to clear the name.

Syntax

name *name*

name - Name of the spanning tree.

Default Setting

Switch's MAC address

Command Mode

MST Configuration

Command Usage

The MST region name and revision number (page 4-226) are used to designate a unique MST region. A bridge (i.e., spanning-tree compliant device such as this switch) can only belong to one MST region. And all bridges in the same region must be configured with the same MST instances.

Example

```
Console(config-mstp)#name R&D
Console(config-mstp)#
```

Related Commands

revision (4-226)

revision

This command configures the revision number for this multiple spanning tree configuration of this switch. Use the **no** form to restore the default.

Syntax

revision *number*

number - Revision number of the spanning tree. (Range: 0-65535)

Default Setting

0

Command Mode

MST Configuration

Command Usage

The MST region name (page 4-225) and revision number are used to designate a unique MST region. A bridge (i.e., spanning-tree compliant device such as this switch) can only belong to one MST region. And all bridges in the same region must be configured with the same MST instances.

Example

```
Console(config-mstp)#revision 1
Console(config-mstp)#
```

Related Commands

name (4-225)

max-hops

This command configures the maximum number of hops in the region before a BPDU is discarded. Use the **no** form to restore the default.

Syntax

max-hops *hop-number*

4 Command Line Interface

hop-number - Maximum hop number for multiple spanning tree.
(Range: 1-40)

Default Setting

20

Command Mode

MST Configuration

Command Usage

An MSTI region is treated as a single node by the STP and RSTP protocols. Therefore, the message age for BPDUs inside an MSTI region is never changed. However, each spanning tree instance within a region, and the internal spanning tree (IST) that connects these instances use a hop count to specify the maximum number of bridges that will propagate a BPDU. Each bridge decrements the hop count by one before passing on the BPDU. When the hop count reaches zero, the message is dropped.

Example

```
Console(config-mstp)#max-hops 30
Console(config-mstp)#
```

spanning-tree spanning-disabled

This command disables the spanning tree algorithm for the specified interface. Use the **no** form to reenable the spanning tree algorithm for the specified interface.

Syntax

[no] spanning-tree spanning-disabled

Default Setting

Enabled

Command Mode

Interface Configuration (Ethernet, Port Channel)

Example

This example disables the spanning tree algorithm for port 5.

```
Console(config)#interface ethernet 1/5
Console(config-if)#spanning-tree spanning-disabled
Console(config-if)#
```

spanning-tree cost

This command configures the spanning tree path cost for the specified interface. Use the **no** form to restore the default.

Syntax

spanning-tree cost *cost*
no spanning-tree cost

cost - The path cost for the port.
(Range: 0 for auto-configuration, or 1-200,000,000)
The recommended range is:

- Ethernet: 200,000-20,000,000
- Fast Ethernet: 20,000-2,000,000
- Gigabit Ethernet: 2,000-200,000
- 10 Gigabit Ethernet: 200-20,000

Default Setting

By default, the system automatically detects the speed and duplex mode used on each port, and configures the path cost according to the values shown below. Path cost "0" is used to indicate auto-configuration mode.

- Ethernet – half duplex: 2,000,000; full duplex: 1,000,000; trunk: 500,000
- Fast Ethernet – half duplex: 200,000; full duplex: 100,000; trunk: 50,000
- Gigabit Ethernet – full duplex: 10,000; trunk: 5,000
- 10 Gigabit Ethernet – full duplex: 1000; trunk: 500

Command Mode

Interface Configuration (Ethernet, Port Channel)

Command Usage

- This command is used by the Spanning Tree Algorithm to determine the best path between devices. Therefore, lower values should be assigned to ports attached to faster media, and higher values assigned to ports with slower media.
- Path cost takes precedence over port priority.
- When the spanning-tree pathcost method (page 4-222) is set to short, the maximum value for path cost is 65,535.

Example

```
Console(config)#interface ethernet 1/5
Console(config-if)#spanning-tree cost 50
Console(config-if)#
```

spanning-tree port-priority

This command configures the priority for the specified interface. Use the **no** form to restore the default.

Syntax

spanning-tree port-priority *priority*
no spanning-tree port-priority

priority - The priority for a port. (Range: 0-240, in steps of 16)

Default Setting

128

Command Mode

4 Command Line Interface

Interface Configuration (Ethernet, Port Channel)

Command Usage

- This command defines the priority for the use of a port in the Spanning Tree Algorithm. If the path cost for all ports on a switch are the same, the port with the highest priority (that is, lowest value) will be configured as an active link in the spanning tree.
- Where more than one port is assigned the highest priority, the port with lowest numeric identifier will be enabled.

Example

```
Console(config)#interface ethernet 1/5
Console(config-if)#spanning-tree port-priority 0
```

Related Commands

spanning-tree cost (4-227)

spanning-tree edge-port

This command specifies an interface as an edge port. Use the **no** form to restore the default.

Syntax

[no] spanning-tree edge-port

Default Setting

Disabled

Command Mode

Interface Configuration (Ethernet, Port Channel)

Command Usage

- You can enable this option if an interface is attached to a LAN segment that is at the end of a bridged LAN or to an end node. Since end nodes cannot cause forwarding loops, they can pass directly through to the spanning tree forwarding state. Specifying Edge Ports provides quicker convergence for devices such as workstations or servers, retains the current forwarding database to reduce the amount of frame flooding required to rebuild address tables during reconfiguration events, does not cause the spanning tree to initiate reconfiguration when the interface changes state, and also overcomes other STA-related timeout problems. However, remember that Edge Port should only be enabled for ports connected to an end-node device.
- This command has the same effect as the **spanning-tree portfast**.

Example

```
Console(config)#interface ethernet 1/5
Console(config-if)#spanning-tree edge-port
Console(config-if)#
```

Related Commands

spanning-tree portfast (4-230)

spanning-tree portfast

This command sets an interface to fast forwarding. Use the **no** form to disable fast forwarding.

Syntax

[no] spanning-tree portfast

Default Setting

Disabled

Command Mode

Interface Configuration (Ethernet, Port Channel)

Command Usage

- This command is used to enable/disable the fast spanning-tree mode for the selected port. In this mode, ports skip the Discarding and Learning states, and proceed straight to Forwarding.
- Since end-nodes cannot cause forwarding loops, they can be passed through the spanning tree state changes more quickly than allowed by standard convergence time. Fast forwarding can achieve quicker convergence for end-node workstations and servers, and also overcome other STA related timeout problems. (Remember that fast forwarding should only be enabled for ports connected to a LAN segment that is at the end of a bridged LAN or for an end-node device.)
- This command is the same as **spanning-tree edge-port**, and is only included for backward compatibility with earlier products. Note that this command may be removed for future software versions.

Example

```
Console(config)#interface ethernet 1/5
Console(config-if)#bridge-group 1 portfast
Console(config-if)#
```

Related Commands

spanning-tree edge-port (4-229)

spanning-tree link-type

This command configures the link type for Rapid Spanning Tree and Multiple Spanning Tree. Use the **no** form to restore the default.

Syntax

```
spanning-tree link-type {auto | point-to-point | shared}  
no spanning-tree link-type
```

- **auto** - Automatically derived from the duplex mode setting.
- **point-to-point** - Point-to-point link.
- **shared** - Shared medium.

Default Setting

auto

Command Mode

Interface Configuration (Ethernet, Port Channel)

Command Usage

- Specify a point-to-point link if the interface can only be connected to exactly one other bridge, or a shared link if it can be connected to two or more bridges.
- When automatic detection is selected, the switch derives the link type from the duplex mode. A full-duplex interface is considered a point-to-point link, while a half-duplex interface is assumed to be on a shared link.
- RSTP only works on point-to-point links between two bridges. If you designate a port as a shared link, RSTP is forbidden. Since MSTP is an extension of RSTP, this same restriction applies.

Example

```
Console(config)#interface ethernet 1/5  
Console(config-if)#spanning-tree link-type point-to-point
```

spanning-tree loopback-detection

This command enables the detection and response to Spanning Tree loopback BPDU packets on the port. Use the **no** form to disable this feature.

Syntax

```
spanning-tree loopback-detection  
no spanning-tree loopback-detection
```

Default Setting

Enabled

Command Mode

Interface Configuration (Ethernet, Port Channel)

Command Usage

- If Port Loopback Detection is not enabled and a port receives its own BPDU, then the port will drop the loopback BPDU according to IEEE Standard 802.1W-2001

9.3.4 (Note 1).

- Port Loopback Detection will not be active if Spanning Tree is disabled on the switch.

Example

```
Console(config)#interface ethernet 1/5
Console(config-if)#spanning-tree loopback-detection
```

spanning-tree loopback-detection release-mode

This command configures the release mode for a port that was placed in the discarding state because a loopback BPDU was received. Use the **no** form to restore the default.

Syntax

spanning-tree loopback-detection release-mode {auto | manual}
no spanning-tree loopback-detection release-mode

- **auto** - Allows a port to automatically be released from the discarding state when the loopback state ends.
- **manual** - The port can only be released from the discarding state manually.

Default Setting

Auto

Command Mode

Interface Configuration (Ethernet, Port Channel)

Command Usage

- If the port is configured for automatic loopback release, then the port will only be returned to the forwarding state if one of the following conditions is satisfied:
 - The port receives any other BPDU except for its own, or;
 - The port's link status changes to link down and then link up again, or;
 - The port ceases to receive its own BPDUs in a forward delay interval.
- If Port Loopback Detection is not enabled and a port receives its own BPDU, then the port will drop the loopback BPDU according to IEEE Standard 802.1W-2001 9.3.4 (Note 1).
- Port Loopback Detection will not be active if Spanning Tree is disabled on the switch.
- When configured for manual release mode, then a link down / up event will not release the port from the discarding state.

Example

```
Console(config)#interface ethernet 1/5
Console(config-if)#spanning-tree loopback-detection release-mode manual
```

spanning-tree loopback-detection trap

This command enables SNMP trap notification for Spanning Tree loopback BPDU detections. Use the **no** form to restore the default.

Syntax

```
spanning-tree loopback-detection trap
no spanning-tree loopback-detection trap
```

Default Setting

Disabled

Command Mode

Interface Configuration (Ethernet, Port Channel)

Example

```
Console(config)#interface ethernet ethernet 1/5
Console(config-if)#spanning-tree loopback-detection trap
```

spanning-tree mst cost

This command configures the path cost on a spanning instance in the Multiple Spanning Tree. Use the **no** form to restore the default.

Syntax

```
spanning-tree mst instance_id cost cost
no spanning-tree mst instance_id cost
```

- *instance_id* - Instance identifier of the spanning tree.
(Range: 0-4094, no leading zeroes)
- *cost* - Path cost for an interface. (Range: 1-200,000,000)
The recommended range is -
 - Ethernet: 200,000-20,000,000
 - Fast Ethernet: 20,000-2,000,000
 - Gigabit Ethernet: 2,000-200,000
 - 10 Gigabit Ethernet: 200-20,000

Default Setting

By default, the system automatically detects the speed and duplex mode used on each port, and configures the path cost according to the values shown below. Path cost "0" is used to indicate auto-configuration mode.

- Ethernet – half duplex: 2,000,000; full duplex: 1,000,000; trunk: 500,000
- Fast Ethernet – half duplex: 200,000; full duplex: 100,000; trunk: 50,000
- Gigabit Ethernet – full duplex: 10,000; trunk: 5,000
- 10 Gigabit Ethernet – full duplex: 1000; trunk: 500

Command Mode

Interface Configuration (Ethernet, Port Channel)

Command Usage

- Each spanning-tree instance is associated with a unique set of VLAN IDs.
- This command is used by the multiple spanning-tree algorithm to determine the best path between devices. Therefore, lower values should be assigned to interfaces attached to faster media, and higher values assigned to interfaces with slower media.
- Use the **no spanning-tree mst cost** command to specify auto-configuration mode.
- Path cost takes precedence over interface priority.

Example

```
Console(config)#interface ethernet ethernet 1/5
Console(config-if)#spanning-tree mst 1 cost 50
Console(config-if)#
```

Related Commands

spanning-tree mst port-priority (4-234)

spanning-tree mst port-priority

This command configures the interface priority on a spanning instance in the Multiple Spanning Tree. Use the **no** form to restore the default.

Syntax

spanning-tree mst *instance_id* port-priority *priority*
no spanning-tree mst *instance_id* port-priority

- *instance_id* - Instance identifier of the spanning tree. (Range: 0-4094, no leading zeroes)
- *priority* - Priority for an interface. (Range: 0-240 in steps of 16)

Default Setting

128

Command Mode

Interface Configuration (Ethernet, Port Channel)

Command Usage

- This command defines the priority for the use of an interface in the multiple spanning-tree. If the path cost for all interfaces on a switch are the same, the interface with the highest priority (that is, lowest value) will be configured as an active link in the spanning tree.
- Where more than one interface is assigned the highest priority, the interface with lowest numeric identifier will be enabled.

Example

```
Console(config)#interface ethernet ethernet 1/5
Console(config-if)#spanning-tree mst 1 port-priority 0
Console(config-if)#
```

Related Commands

4 Command Line Interface

spanning-tree mst cost (4-233)

spanning-tree protocol-migration

This command re-checks the appropriate BPDU format to send on the selected interface.

Syntax

spanning-tree protocol-migration *interface*

interface

- **ethernet** *unit/port*
 - *unit* - Stack unit. (Range: 1)
 - *port* - Port number. (Range: 1-28/52)
- **port-channel** *channel-id* (Range: 1-8)

Command Mode

Privileged Exec

Command Usage

If at any time the switch detects STP BPDUs, including Configuration or Topology Change Notification BPDUs, it will automatically set the selected interface to forced STP-compatible mode. However, you can also use the **spanning-tree protocol-migration** command at any time to manually re-check the appropriate BPDU format to send on the selected interfaces (i.e., RSTP or STP-compatible).

Example

```
Console#spanning-tree protocol-migration eth 1/5
Console#
```

show spanning-tree

This command shows the configuration for the common spanning tree (CST) or for an instance within the multiple spanning tree (MST).

Syntax

show spanning-tree [*interface* | **mst** *instance_id*]

- *interface*
- **ethernet** *unit/port*
 - *unit* - Stack unit. (Range: 1)
 - *port* - Port number. (Range: 1-28/52)
- **port-channel** *channel-id* (Range: 1-8)
- *instance_id* - Instance identifier of the multiple spanning tree. (Range: 0-4094, no leading zeroes)

Default Setting

None

Command Mode

Privileged Exec

Command Usage

- Use the **show spanning-tree** command with no parameters to display the spanning tree configuration for the switch for the Common Spanning Tree (CST) and for every interface in the tree.
- Use the **show spanning-tree interface** command to display the spanning tree configuration for an interface within the Common Spanning Tree (CST).
- Use the **show spanning-tree mst instance_id** command to display the spanning tree configuration for an instance within the Multiple Spanning Tree (MST).
- For a description of the items displayed under “Spanning-tree information,” see “Configuring Global Settings” on page 3-142. For a description of the items displayed for specific interfaces, see “Displaying Interface Settings” on page 3-146.

Example

```
Console#show spanning-tree
Spanning-tree information
-----
Spanning tree mode:                MSTP
Spanning tree enable/disable:      enable
Instance:                          0
Vlans configuration:               1-4092
Priority:                          32768
Bridge Hello Time (sec.):          2
Bridge Max Age (sec.):             20
Bridge Forward Delay (sec.):       15
Root Hello Time (sec.):            2
Root Max Age (sec.):               20
Root Forward Delay (sec.):         15
Max hops:                          20
Remaining hops:                    20
Designated Root:                   32768.0.0000ABCD0000
Current root port:                  1
Current root cost:                  10000
Number of topology changes:        1
Last topology changes time (sec.): 22
Transmission limit:                 3
Path Cost Method:                   long
```

4 Command Line Interface

```
-----  
Eth 1/ 1 information  
-----  
Admin status:          enable  
Role:                  root  
State:                 forwarding  
External admin path cost: 10000  
Internal admin cost:   10000  
External oper path cost: 10000  
Internal oper path cost: 10000  
Priority:              128  
Designated cost:      200000  
Designated port:      128.24  
Designated root:      32768.0.0000ABCD0000  
Designated bridge:    32768.0.0030F1552000  
Fast forwarding:      disable  
Forward transitions:   1  
Admin edge port:      enable  
Oper edge port:       disable  
Admin Link type:      auto  
Oper Link type:       point-to-point  
Spanning Tree Status: enable  
:  
:
```

show spanning-tree mst configuration

This command shows the configuration of the multiple spanning tree.

Command Mode

Privileged Exec

Example

```
Console#show spanning-tree mst configuration  
Mstp Configuration Information  
-----  
Configuration name: R&D  
Revision level:0  
  
Instance Vlans  
-----  
1      2  
Console#
```

VLAN Commands

A VLAN is a group of ports that can be located anywhere in the network, but communicate as though they belong to the same physical segment. This section describes commands used to create VLAN groups, add port members, specify how VLAN tagging is used, and enable automatic VLAN registration for the selected interface.

Table 4-13 VLANs

Command Groups	Function	Page
GVRP and Bridge Extension	Configures GVRP settings that permit automatic VLAN learning; shows the configuration for bridge extension MIB	4-238
Editing VLAN Groups	Sets up VLAN groups, including name, VID and state	4-242
Configuring VLAN Interfaces	Configures VLAN interface parameters, including ingress and egress tagging mode, ingress filtering, PVID, and GVRP	4-244
Displaying VLAN Information	Displays VLAN groups, status, port members, and MAC addresses	4-250
Configuring 802.1Q Tunneling	Configures 802.1Q Tunneling (QinQ Tunneling)	4-251
Configuring Private VLANs	Configures private VLANs, including uplink and downlink ports	4-254
Configuring Protocol VLANs	Configures protocol-based VLANs based on frame type and protocol	4-261

GVRP and Bridge Extension Commands

GARP VLAN Registration Protocol defines a way for switches to exchange VLAN information in order to automatically register VLAN members on interfaces across the network. This section describes how to enable GVRP for individual interfaces and globally for the switch, as well as how to display default configuration settings for the Bridge Extension MIB.

Table 4-14 GVRP and Bridge Extension Commands

Command	Function	Mode	Page
bridge-ext gvrp	Enables GVRP globally for the switch	GC	4-239
show bridge-ext	Shows the global bridge extension configuration	PE	4-239
switchport gvrp	Enables GVRP for an interface	IC	4-240
switchport forbidden vlan	Configures forbidden VLANs for an interface	IC	4-249
show gvrp configuration	Displays GVRP configuration for the selected interface	NE, PE	4-240
garp timer	Sets the GARP timer for the selected function	IC	4-241
show garp timer	Shows the GARP timer for the selected function	NE, PE	4-241

bridge-ext gvrp

This command enables GVRP globally for the switch. Use the **no** form to disable it.

Syntax

[no] bridge-ext gvrp

Default Setting

Disabled

Command Mode

Global Configuration

Command Usage

GVRP defines a way for switches to exchange VLAN information in order to register VLAN members on ports across the network. This function should be enabled to permit automatic VLAN registration, and to support VLANs which extend beyond the local switch.

Example

```
Console(config)#bridge-ext gvrp
Console(config)#
```

show bridge-ext

This command shows the configuration for bridge extension commands.

Default Setting

None

Command Mode

Privileged Exec

Command Usage

See “Displaying Basic VLAN Information” on page 3-161 and “Displaying Bridge Extension Capabilities” on page 3-15 for a description of the displayed items.

Example

```
Console#show bridge-ext
Max support vlan numbers:          256
Max support vlan ID:               4092
Extended multicast filtering services: No
Static entry individual port:      Yes
VLAN learning:                     IVL
Configurable PVID tagging:         Yes
Local VLAN capable:                No
Traffic classes:                   Enabled
Global GVRP status:                Enabled
GMRP:                               Disabled
Console#
```

switchport gvrp

This command enables GVRP for a port. Use the **no** form to disable it.

Syntax

```
[no] switchport gvrp
```

Default Setting

Disabled

Command Mode

Interface Configuration (Ethernet, Port Channel)

Example

```
Console(config)#interface ethernet 1/6
Console(config-if)#switchport gvrp
Console(config-if)#
```

show gvrp configuration

This command shows if GVRP is enabled.

Syntax

```
show gvrp configuration [interface]
```

interface

- **ethernet** *unit/port*
 - *unit* - Stack unit. (Range: 1)
 - *port* - Port number. (Range: 1-28/52)
- **port-channel** *channel-id* (Range: 1-8)

Default Setting

Shows both global and interface-specific configuration.

Command Mode

Normal Exec, Privileged Exec

Example

```
Console#show gvrp configuration ethernet 1/6
Eth 1/ 6:
  GVRP configuration: Enabled
Console#
```

garp timer

This command sets the values for the join, leave and leaveall timers. Use the **no** form to restore the timers' default values.

Syntax

```
garp timer {join | leave | leaveall} timer_value  
no garp timer {join | leave | leaveall}
```

- {join | leave | leaveall} - Which timer to set.
- *timer_value* - Value of timer.

Ranges:

join: 20-1000 centiseconds

leave: 60-3000 centiseconds

leaveall: 500-18000 centiseconds

Default Setting

- join: 20 centiseconds
- leave: 60 centiseconds
- leaveall: 1000 centiseconds

Command Mode

Interface Configuration (Ethernet, Port Channel)

Command Usage

- Group Address Registration Protocol is used by GVRP and GMRP to register or deregister client attributes for client services within a bridged LAN. The default values for the GARP timers are independent of the media access method or data rate. These values should not be changed unless you are experiencing difficulties with GMRP or GVRP registration/deregistration.
- Timer values are applied to GVRP for all the ports on all VLANs.
- Timer values must meet the following restrictions:
 - leave \geq (2 x join)
 - leaveall > leave

Note: Set GVRP timers on all Layer 2 devices connected in the same network to the same values. Otherwise, GVRP may not operate successfully.

Example

```
Console(config)#interface ethernet 1/1  
Console(config-if)#garp timer join 100  
Console(config-if)#
```

Related Commands

show garp timer (4-241)

show garp timer

This command shows the GARP timers for the selected interface.

Syntax

show garp timer [*interface*]

interface

- **ethernet** *unit/port*
 - *unit* - Stack unit. (Range: 1)
 - *port* - Port number. (Range: 1-28/52)
- **port-channel** *channel-id* (Range: 1-8)

Default Setting

Shows all GARP timers.

Command Mode

Normal Exec, Privileged Exec

Example

```
Console#show garp timer ethernet 1/1
Eth 1/ 1 GARP timer status:
Join timer:    100 centiseconds
Leave timer:    60 centiseconds
Leaveall timer: 1000 centiseconds
Console#
```

Related Commands

garp timer (4-241)

Editing VLAN Groups

Table 4-15 Editing VLAN Groups

Command	Function	Mode	Page
vlan database	Enters VLAN database mode to add, change, and delete VLANs	GC	4-242
vlan	Configures a VLAN, including VID, name and state	VC	4-243

vlan database

This command enters VLAN database mode. All commands in this mode will take effect immediately.

Default Setting

None

Command Mode

Global Configuration

Command Usage

- Use the VLAN database command mode to add, change, and delete VLANs. After finishing configuration changes, you can display the VLAN settings by entering the **show vlan** command.
- Use the **interface vlan** command mode to define the port membership mode and add or remove ports from a VLAN. The results of these commands are written to the running-configuration file, and you can display this file by entering the **show running-config** command.

Example

```
Console(config)#vlan database
Console(config-vlan)#
```

Related Commands

show vlan (4-250)

vlan

This command configures a VLAN. Use the **no** form to restore the default settings or delete a VLAN.

Syntax

```
vlan vlan-id [name vlan-name] media ethernet [state {active | suspend}]
no vlan vlan-id [name | state]
```

- *vlan-id* - ID of configured VLAN. (Range: 1-4092, no leading zeroes)
- **name** - Keyword to be followed by the VLAN name.
 - *vlan-name* - ASCII string from 1 to 32 characters.
- **media ethernet** - Ethernet media type.
- **state** - Keyword to be followed by the VLAN state.
 - **active** - VLAN is operational.
 - **suspend** - VLAN is suspended. Suspended VLANs do not pass packets.

Default Setting

By default only VLAN 1 exists and is active.

Command Mode

VLAN Database Configuration

Command Usage

- **no vlan** *vlan-id* deletes the VLAN.
- **no vlan** *vlan-id* **name** removes the VLAN name.
- **no vlan** *vlan-id* **state** returns the VLAN to the default state (i.e., active).
- You can configure up to 255 VLANs on the switch.

Note: The switch allows 255 user-manageable VLANs. One extra, unmanageable VLAN (VLAN ID 4093) is maintained for switch clustering.

Example

The following example adds a VLAN, using VLAN ID 105 and name RD5. The VLAN is activated by default.

```
Console(config)#vlan database
Console(config-vlan)#vlan 105 name RD5 media ethernet
Console(config-vlan)#
```

Related Commands

show vlan (4-250)

Configuring VLAN Interfaces

Table 4-16 Configuring VLAN Interfaces

Command	Function	Mode	Page
interface vlan	Enters interface configuration mode for a specified VLAN	GC	4-244
switchport mode	Configures VLAN membership mode for an interface	IC	4-245
switchport acceptable-frame-types	Configures frame types to be accepted by an interface	IC	4-246
switchport ingress-filtering	Enables ingress filtering on an interface	IC	4-246
switchport native vlan	Configures the PVID (native VLAN) of an interface	IC	4-247
switchport allowed vlan	Configures the VLANs associated with an interface	IC	4-248
switchport gvrp	Enables GVRP for an interface	IC	4-240
switchport forbidden vlan	Configures forbidden VLANs for an interface	IC	4-249
switchport priority default	Sets a port priority for incoming untagged frames	IC	4-265

interface vlan

This command enters interface configuration mode for VLANs, which is used to configure VLAN parameters for a physical interface.

Syntax

interface vlan *vlan-id*

vlan-id - ID of the configured VLAN. (Range: 1-4092, no leading zeroes)

Default Setting

None

Command Mode

Global Configuration

Example

The following example shows how to set the interface configuration mode to VLAN 1, and then assign an IP address to the VLAN:

```
Console(config)#interface vlan 1
Console(config-if)#ip address 192.168.1.254 255.255.255.0
Console(config-if)#
```

Related Commands

shutdown (4-171)

switchport mode

This command configures the VLAN membership mode for a port. Use the **no** form to restore the default.

Syntax

switchport mode {trunk | hybrid | private-vlan}
no switchport mode

- **trunk** - Specifies a port as an end-point for a VLAN trunk. A trunk is a direct link between two switches, so the port transmits tagged frames that identify the source VLAN. Note that frames belonging to the port's default VLAN (i.e., associated with the PVID) are also transmitted as tagged frames.
- **hybrid** - Specifies a hybrid VLAN interface. The port may transmit tagged or untagged frames.
- **private-vlan** - For an explanation of this command see "switchport mode private-vlan" on page 4-257.

Default Setting

All ports are in hybrid mode with the PVID set to VLAN 1.

Command Mode

Interface Configuration (Ethernet, Port Channel)

Example

The following shows how to set the configuration mode to port 1, and then set the switchport mode to hybrid:

```
Console(config)#interface ethernet 1/1
Console(config-if)#switchport mode hybrid
Console(config-if)#
```

Related Commands

switchport acceptable-frame-types (4-246)

switchport acceptable-frame-types

This command configures the acceptable frame types for a port. Use the **no** form to restore the default.

Syntax

```
switchport acceptable-frame-types {all | tagged}
no switchport acceptable-frame-types
```

- **all** - The port accepts all frames, tagged or untagged.
- **tagged** - The port only receives tagged frames.

Default Setting

All frame types

Command Mode

Interface Configuration (Ethernet, Port Channel)

Command Usage

When set to receive all frame types, any received frames that are untagged are assigned to the default VLAN.

Example

The following example shows how to restrict the traffic received on port 1 to tagged frames:

```
Console(config)#interface ethernet 1/1
Console(config-if)#switchport acceptable-frame-types tagged
Console(config-if)#
```

Related Commands

switchport mode (4-245)

switchport ingress-filtering

This command enables ingress filtering for an interface.

Note: Although the ingress filtering command is available, the switch has ingress filtering permanently set to enable. Therefore, trying to disable the filtering with the **no switchport ingress-filtering** command will produce this error message:
"Note: Failed to ingress-filtering on ethernet interface !"

Syntax

```
switchport ingress-filtering
no switchport ingress-filtering
```

Default Setting

Enabled

4 Command Line Interface

Command Mode

Interface Configuration (Ethernet, Port Channel)

Command Usage

- Ingress filtering only affects tagged frames.
- With ingress filtering enabled, a port will discard received frames tagged for VLANs for which it is not a member.
- Ingress filtering does not affect VLAN independent BPDU frames, such as GVRP or STA. However, they do affect VLAN dependent BPDU frames, such as GMRP.

Example

The following example shows how to select port 1 and then enable ingress filtering:

```
Console(config)#interface ethernet 1/1
Console(config-if)#switchport ingress-filtering
Console(config-if)#
```

switchport native vlan

This command configures the PVID (i.e., default VLAN ID) for a port. Use the **no** form to restore the default.

Syntax

switchport native vlan *vlan-id*
no switchport native vlan

vlan-id - Default VLAN ID for a port. (Range: 1-4092, no leading zeroes)

Default Setting

VLAN 1

Command Mode

Interface Configuration (Ethernet, Port Channel)

Command Usage

- Setting the native VLAN for a port can only be performed when the port is a member of the VLAN and the VLAN is untagged. The **no switchport native vlan** command will set the native VLAN of the port to untagged VLAN 1.
- If acceptable frame types is set to **all** or switchport mode is set to **hybrid**, the PVID will be inserted into all untagged frames entering the ingress port.

Example

The following example shows how to set the PVID for port 1 to VLAN 3:

```
Console(config)#interface ethernet 1/1
Console(config-if)#switchport native vlan 3
Console(config-if)#
```

switchport allowed vlan

This command configures VLAN groups on the selected interface. Use the **no** form to restore the default.

Note: Each port can only have one untagged VLAN. If a second VLAN is defined for a port as untagged, the other VLAN that had untagged status will automatically be changed to tagged. Setting a VLAN untagged will also change the native VLAN of the port to this VLAN.

Syntax

```
switchport allowed vlan {add vlan-list [tagged | untagged] |  
remove vlan-list}
```

no switchport allowed vlan

- **add** *vlan-list* - List of VLAN identifiers to add.
- **remove** *vlan-list* - List of VLAN identifiers to remove.
- *vlan-list* - Separate nonconsecutive VLAN identifiers with a comma and no spaces; use a hyphen to designate a range of IDs. Do not enter leading zeros. (Range: 1-4092).

Default Setting

All ports are assigned to VLAN 1 by default.
The default frame type is untagged.

Command Mode

Interface Configuration (Ethernet, Port Channel)

Command Usage

- A port, or a trunk with switchport mode set to **hybrid**, must be assigned to a VLAN as untagged.
- If a trunk has switchport mode set to **trunk** (i.e., 1Q Trunk), then you can only assign an interface to VLAN groups as a tagged member.
- Frames are always tagged within the switch. The tagged/untagged parameter used when adding a VLAN to an interface tells the switch whether to keep or remove the tag from a frame on egress.
- The interface can be added to a VLAN as an untagged member regardless of connected devices to this interface. The default setting is untagged VLAN 1. Note that each port can only have one untagged VLAN. If a second VLAN is defined for a port as untagged, the other VLAN that had untagged status will automatically be changed to tagged. Setting a VLAN untagged will also change the native VLAN of the port to this VLAN.
- If a VLAN on the forbidden list for an interface is manually added to that interface, the VLAN is automatically removed from the forbidden list for that interface.

Example

The following example shows how to add VLANs 1, 2, 5 and 6 to the allowed list as tagged VLANs for port 1:

```
Console(config)#interface ethernet 1/1
Console(config-if)#switchport allowed vlan add 1,2,5,6 tagged
Console(config-if)#
```

switchport forbidden vlan

This command configures forbidden VLANs. Use the **no** form to remove the list of forbidden VLANs.

Syntax

switchport forbidden vlan {add *vlan-list* | remove *vlan-list*}
no switchport forbidden vlan

- **add *vlan-list*** - List of VLAN identifiers to add.
- **remove *vlan-list*** - List of VLAN identifiers to remove.
- ***vlan-list*** - Separate nonconsecutive VLAN identifiers with a comma and no spaces; use a hyphen to designate a range of IDs. Do not enter leading zeros. (Range: 1-4092).

Default Setting

No VLANs are included in the forbidden list.

Command Mode

Interface Configuration (Ethernet, Port Channel)

Command Usage

- This command prevents a VLAN from being automatically added to the specified interface via GVRP.
- If a VLAN has been added to the set of allowed VLANs for an interface, then you cannot add it to the set of forbidden VLANs for that same interface.

Example

The following example shows how to prevent port 1 from being added to VLAN 3:

```
Console(config)#interface ethernet 1/1
Console(config-if)#switchport forbidden vlan add 3
Console(config-if)#
```

Displaying VLAN Information

Table 4-17 Show VLAN Commands

Command	Function	Mode	Page
show vlan	Shows VLAN information	NE, PE	4-250
show interfaces status vlan	Displays status for the specified VLAN interface	NE, PE	4-173
show interfaces switchport	Displays the administrative and operational status of an interface	NE, PE	4-175

show vlan

This command shows VLAN information.

Syntax

show vlan [*id* *vlan-id* | *name* *vlan-name* | *private-vlan* *private-vlan-type*]

- **id** - Keyword to be followed by the VLAN ID.
 - *vlan-id* - ID of the configured VLAN. (Range: 1-4092, no leading zeroes)
- **name** - Keyword to be followed by the VLAN name.
 - *vlan-name* - ASCII string from 1 to 32 characters.
- **private-vlan** - For an explanation of this command see “show vlan private-vlan” on page 4-259
 - *private-vlan-type* - Indicates the private vlan type. (Options: Community, Isolated, Primary)

Default Setting

Shows all VLANs.

Command Mode

Normal Exec, Privileged Exec

Example

The following example shows how to display information for VLAN 1:

```

Console#show vlan id 1
Default VLAN ID : 1

VLAN ID:          1
Type:             Static
Name:            DefaultVlan
Status:          Active
Ports/Port Channels:  Eth1/ 1(S) Eth1/ 2(S) Eth1/ 3(S) Eth1/ 4(S) Eth1/ 5(S)
                       Eth1/ 6(S) Eth1/ 7(S) Eth1/ 8(S) Eth1/ 9(S) Eth1/10(S)
                       Eth1/11(S) Eth1/12(S) Eth1/13(S) Eth1/14(S) Eth1/15(S)
                       Eth1/16(S) Eth1/17(S) Eth1/18(S) Eth1/19(S) Eth1/20(S)
                       Eth1/21(S) Eth1/22(S) Eth1/23(S) Eth1/24(S) Eth1/25(S)
                       Eth1/26(S) Eth1/27(S) Eth1/28(S)

Console#

```

Configuring IEEE 802.1Q Tunneling

IEEE 802.1Q tunneling (QinQ tunneling) uses a single Service Provider VLAN (SPVLAN) for customers who have multiple VLANs. Customer VLAN IDs are preserved and traffic from different customers is segregated within the service provider's network even when they use the same customer-specific VLAN IDs. QinQ tunneling expands VLAN space by using a VLAN-in-VLAN hierarchy, preserving the customer's original tagged packets, and adding SPVLAN tags to each frame (also called double tagging).

This section describes commands used to configure QinQ tunneling.

Table 4-18 IEEE 802.1Q Tunneling Commands

Command	Function	Mode	Page
dot1q-tunnel system-tunnel-control	Configures the switch to operate in normal mode or QinQ mode	GC	4-251
switchport dot1q-tunnel mode	Configures an interface as a QinQ tunnel port	IC	4-252
switchport dot1q-tunnel tpid	Sets the Tag Protocol Identifier (TPID) value of a tunnel port	IC	4-253
show dot1q-tunnel	Displays the configuration of QinQ tunnel ports	PE	4-253
show interfaces switchport	Displays port QinQ operational status	PE	4-175

General Configuration Guidelines for QinQ

1. Configure the switch to QinQ mode (**dot1q-tunnel system-tunnel-control**, page 4-251).
2. Create a SPVLAN (**vlan**, page 4-243).
3. Configure the QinQ tunnel access port to dot1Q-tunnel access mode (**switchport dot1q-tunnel mode**, page 4-252).
4. Set the Tag Protocol Identifier (TPID) value of the tunnel access port. This step is required if the attached client is using a nonstandard 2-byte ethertype to identify 802.1Q tagged frames. The standard ethertype value is 0x8100. (See **switchport dot1q-tunnel tpid**, page 4-253.)
5. Configure the QinQ tunnel access port to join the SPVLAN as an untagged member (**switchport allowed vlan**, page 4-248).
6. Configure the SPVLAN ID as the native VID on the QinQ tunnel access port (**switchport native vlan**, page 4-247).
7. Configure the QinQ tunnel uplink port to dot1Q-tunnel uplink mode (**switchport dot1q-tunnel mode**, page 4-252).
8. Configure the QinQ tunnel uplink port to join the SPVLAN as a tagged member (**switchport allowed vlan**, page 4-248).

dot1q-tunnel system-tunnel-control

This command sets the switch to operate in QinQ mode. Use the **no** form to disable QinQ operating mode.

Syntax

[no] dot1q-tunnel system-tunnel-control

Default Setting

Disabled

Command Mode

Global Configuration

Command Usage

QinQ tunnel mode must be enabled on the switch for QinQ interface settings to be functional.

Example

```
Console(config)#dot1q-tunnel system-tunnel-control
Console(config)#
```

Related Commands

show dot1q-tunnel (4-253)
show interfaces switchport (4-175)

switchport dot1q-tunnel mode

This command configures an interface as a QinQ tunnel port. Use the **no** form to disable QinQ on the interface.

Syntax

switchport dot1q-tunnel mode <access | uplink>
no switchport dot1q-tunnel mode

- **access** – Sets the port as an 802.1Q tunnel access port.
- **uplink** – Sets the port as an 802.1Q tunnel uplink port.

Default Setting

Disabled

Command Mode

Interface Configuration (Ethernet, Port Channel)

Command Usage

Use the **dot1q-tunnel system-tunnel-control** command to set the switch to QinQ mode before entering this command.

Example

```
Console(config)#interface ethernet 1/1
Console(config-if)#switchport dot1q-tunnel mode access
Console(config-if)#
```

Related Commands

show dot1q-tunnel (4-253)
show interfaces switchport (4-175)

switchport dot1q-tunnel tpid

This command sets the Tag Protocol Identifier (TPID) value of a tunnel port. Use the **no** form to restore the default setting.

Syntax

```
switchport dot1q-tunnel tpid tpid  
no switchport dot1q-tunnel tpid
```

tpid – Sets the ethertype value for 802.1Q encapsulation. This identifier is used to select a nonstandard 2-byte ethertype to identify 802.1Q tagged frames. The standard ethertype value is 0x8100. (Range: 0800-FFFF hexadecimal)

Default Setting

0x8100

Command Mode

Interface Configuration (Ethernet, Port Channel)

Command Usage

- Use the **switchport dot1q-tunnel tpid** command to set a custom 802.1Q ethertype value on the selected interface. This feature allows the switch to interoperate with third-party switches that do not use the standard 0x8100 ethertype to identify 802.1Q-tagged frames. For example, 0x1234 is set as the custom 802.1Q ethertype on a trunk port, incoming frames containing that ethertype are assigned to the VLAN contained in the tag following the ethertype field, as they would be with a standard 802.1Q trunk. Frames arriving on the port containing any other ethertype are looked upon as untagged frames, and assigned to the native VLAN of that port.
- All ports on the switch will be set to the same ethertype.

Example

```
Console(config)#interface ethernet 1/1  
Console(config-if)#switchport dot1q-tunnel tpid 9100  
Console(config-if)#
```

Related Commands

show interfaces switchport (4-175)

show dot1q-tunnel

This command displays information about QinQ tunnel ports.

Command Mode

Privileged Exec

Example

```

Console(config)#dot1q-tunnel system-tunnel-control
Console(config)#interface ethernet 1/1
Console(config-if)#switchport dot1q-tunnel mode access
Console(config-if)#interface ethernet 1/2
Console(config-if)#switchport dot1q-tunnel mode uplink
Console(config-if)#end
Console#show dot1q-tunnel

Current double-tagged status of the system is Enabled

The dot1q-tunnel mode of the set interface 1/1 is Access mode, TPID is 0x8100.
The dot1q-tunnel mode of the set interface 1/2 is Uplink mode, TPID is 0x8100.
The dot1q-tunnel mode of the set interface 1/3 is Normal mode, TPID is 0x8100.
The dot1q-tunnel mode of the set interface 1/4 is Normal mode, TPID is 0x8100.
The dot1q-tunnel mode of the set interface 1/5 is Normal mode, TPID is 0x8100.
The dot1q-tunnel mode of the set interface 1/6 is Normal mode, TPID is 0x8100.
The dot1q-tunnel mode of the set interface 1/7 is Normal mode, TPID is 0x8100.
.
.
.
.
The dot1q-tunnel mode of the set interface 1/24 is Normal mode, TPID is 0x8100.
Console#

```

Related Commands

switchport dot1q-tunnel mode (4-252)

Configuring Private VLANs

Private VLANs provide port-based security and isolation between ports within the assigned VLAN. This switch supports two types of private VLANs: primary/secondary associated groups, and stand-alone isolated VLANs. A primary VLAN contains promiscuous ports that can communicate with all other ports in the private VLAN group, while a secondary (or community) VLAN contains community ports that can only communicate with other hosts within the secondary VLAN and with any of the promiscuous ports in the associated primary VLAN. Isolated VLANs, on the other hand, consist a single stand-alone VLAN that contains one promiscuous port and one or more isolated (or host) ports. In all cases, the promiscuous ports are designed to provide open access to an external network such as the Internet, while the community or isolated ports provide restricted access to local users.

Multiple primary VLANs can be configured on this switch, and multiple community VLANs can be associated with each primary VLAN. One or more isolated VLANs can also be configured. (Note that private VLANs and normal VLANs can exist simultaneously within the same switch.)

This section describes commands used to configure private VLANs.

Table 4-19 Private VLAN Commands

Command	Function	Mode	Page
<i>Edit Private VLAN Groups</i>			
private-vlan	Adds or deletes primary, community, or isolated VLANs	VC	4-256

Table 4-19 Private VLAN Commands

Command	Function	Mode	Page
private-vlan association	Associates a community VLAN with a primary VLAN	VC	4-256
<i>Configure Private VLAN Interfaces</i>			
switchport mode private-vlan	Sets an interface to host mode or promiscuous mode	IC	4-257
switchport private-vlan host-association	Associates an interface with a secondary VLAN	IC	4-258
switchport private-vlan isolated	Associates an interface with an isolated VLAN	IC	4-258
switchport private-vlan mapping	Maps an interface to a primary VLAN	IC	4-259
<i>Display Private VLAN Information</i>			
show vlan private-vlan	Shows private VLAN information	NE, PE	4-259

To configure primary/secondary associated groups, follow these steps:

1. Use the **private-vlan** command to designate one or more community VLANs and the primary VLAN that will channel traffic outside of the community groups.
2. Use the **private-vlan association** command to map the community VLAN(s) to the primary VLAN.
3. Use the **switchport mode private-vlan** command to configure ports as promiscuous (i.e., having access to all ports in the primary VLAN) or host (i.e., community port).
4. Use the **switchport private-vlan host-association** command to assign a port to a secondary VLAN.
5. Use the **switchport private-vlan mapping** command to assign a port to a primary VLAN.
6. Use the **show vlan private-vlan** command to verify your configuration settings.

To configure isolated VLANs, follow these steps:

1. Use the **private-vlan** command to designate an isolated VLAN that will contain a single promiscuous port and one or more isolated ports.
2. Use the **switchport mode private-vlan** command to configure one port as promiscuous (i.e., having access to all ports in the isolated VLAN) one or more ports as host (i.e., isolated port).
3. Use the **switchport private-vlan isolated** command to assign a port to an isolated VLAN.
4. Use the **show vlan private-vlan** command to verify your configuration settings.

private-vlan

Use this command to create a primary, community, or isolated private VLAN. Use the **no** form to remove the specified private VLAN.

Syntax

```
private-vlan vlan-id {community | primary | isolated}  
no private-vlan vlan-id
```

- *vlan-id* - ID of private VLAN. (Range: 1-4092, no leading zeroes).
- **community** - A VLAN in which traffic is restricted to host members in the same VLAN and to promiscuous ports in the associate primary VLAN.
- **primary** - A VLAN which can contain one or more community VLANs, and serves to channel traffic between community VLANs and other locations.
- **isolated** – Specifies an isolated VLAN. Ports assigned to an isolated VLAN can only communicate with the promiscuous port within their own VLAN.

Default Setting

None

Command Mode

VLAN Configuration

Command Usage

- Private VLANs are used to restrict traffic to ports within the same community or isolated VLAN, and channel traffic passing outside the community through promiscuous ports. When using community VLANs, they must be mapped to an associated “primary” VLAN that contains promiscuous ports. When using an isolated VLAN, it must be configured to contain a single promiscuous port.
- Port membership for private VLANs is static. Once a port has been assigned to a private VLAN, it cannot be dynamically moved to another VLAN via GVRP.
- Private VLAN ports cannot be set to trunked mode. (See “switchport mode” on page 4-245.)

Example

```
Console(config)#vlan database  
Console(config-vlan)#private-vlan 2 primary  
Console(config-vlan)#private-vlan 3 community  
Console(config)#
```

private vlan association

Use this command to associate a primary VLAN with a secondary (i.e., community) VLAN. Use the **no** form to remove all associations for the specified primary VLAN.

Syntax

```
private-vlan primary-vlan-id association {secondary-vlan-id |  
add secondary-vlan-id | remove secondary-vlan-id}
```

4 Command Line Interface

no private-vlan *primary-vlan-id* association

- *primary-vlan-id* - ID of primary VLAN.
(Range: 1-4092, no leading zeroes).
- *secondary-vlan-id* - ID of secondary (i.e, community) VLAN.
(Range: 1-4092, no leading zeroes).

Default Setting

None

Command Mode

VLAN Configuration

Command Usage

Secondary VLANs provide security for group members. The associated primary VLAN provides a common interface for access to other network resources within the primary VLAN (e.g., servers configured with promiscuous ports) and to resources outside of the primary VLAN (via promiscuous ports).

Example

```
Console(config-vlan)#private-vlan 2 association 3
Console(config)#
```

switchport mode private-vlan

Use this command to set the private VLAN mode for an interface. Use the **no** form to restore the default setting.

Syntax

switchport mode private-vlan {host | promiscuous}

no switchport mode private-vlan

- **host** – This port type can subsequently be assigned to a community or isolated VLAN.
- **promiscuous** – This port type can communicate with all other promiscuous ports in the same primary VLAN, as well as with all the ports in the associated secondary VLANs.

Default Setting

Normal VLAN

Command Mode

Interface Configuration (Ethernet, Port Channel)

Command Usage

- To assign a promiscuous port to a primary VLAN, use the **switchport private-vlan mapping** command. To assign a host port to a community VLAN, use the **private-vlan host association** command.

- To assign a promiscuous port or host port to an isolated VLAN, use the **switchport private-vlan isolated** command.

Example

```
Console(config)#interface ethernet 1/2
Console(config-if)#switchport mode private-vlan promiscuous
Console(config-if)#exit
Console(config)#interface ethernet 1/3
Console(config-if)#switchport mode private-vlan host
Console(config-if)#
```

switchport private-vlan host-association

Use this command to associate an interface with a secondary VLAN. Use the **no** form to remove this association.

Syntax

switchport private-vlan host-association *secondary-vlan-id*
no switchport private-vlan host-association

secondary-vlan-id - ID of secondary (i.e., community) VLAN.
(Range: 1-4092, no leading zeroes).

Default Setting

None

Command Mode

Interface Configuration (Ethernet, Port Channel)

Command Usage

All ports assigned to a secondary (i.e., community) VLAN can pass traffic between group members, but must communicate with resources outside of the group via promiscuous ports in the associated primary VLAN.

Example

```
Console(config)#interface ethernet 1/3
Console(config-if)#switchport private-vlan host-association 3
Console(config-if)#
```

switchport private-vlan isolated

Use this command to assign an interface to an isolated VLAN. Use the **no** form to remove this assignment.

Syntax

switchport private-vlan isolated *isolated-vlan-id*
no switchport private-vlan isolated

isolated-vlan-id - ID of isolated VLAN. (Range: 1-4092).

4 Command Line Interface

Default Setting

None

Command Mode

Interface Configuration (Ethernet, Port Channel)

Command Usage

Host ports assigned to a isolated VLAN cannot pass traffic between group members, and must communicate with resources outside of the group via a promiscuous port.

Example

```
Console(config)#interface ethernet 1/3
Console(config-if)#switchport private-vlan isolated 3
Console(config-if)#
```

switchport private-vlan mapping

Use this command to map an interface to a primary VLAN. Use the **no** form to remove this mapping.

Syntax

switchport private-vlan mapping *primary-vlan-id*
no switchport private-vlan mapping

primary-vlan-id – ID of primary VLAN. (Range: 1-4092, no leading zeroes).

Default Setting

None

Command Mode

Interface Configuration (Ethernet, Port Channel)

Command Usage

Promiscuous ports assigned to a primary VLAN can communicate with any other promiscuous ports in the same VLAN, and with the group members within any associated secondary VLANs.

Example

```
Console(config)#interface ethernet 1/2
Console(config-if)#switchport private-vlan mapping 2
Console(config-if)#
```

show vlan private-vlan

Use this command to show the private VLAN configuration settings on this switch.

Syntax

show vlan private-vlan [community | isolated | primary]

- **community** – Displays all community VLANs, along with their associated primary VLAN and assigned host interfaces.
- **isolated** – Displays an isolated VLAN, along with the assigned promiscuous interface and host interfaces. The Primary and Secondary fields both display the isolated VLAN ID.
- **primary** – Displays all primary VLANs, along with any assigned promiscuous interfaces.

Default Setting

None

Command Mode

Privileged Executive

Example

```
Console#show vlan private-vlan
Primary   Secondary   Type           Interfaces
-----
5         5           primary        Eth1/ 3
5         6           community      Eth1/ 4 Eth1/ 5
0         8           isolated
```

```
Console#
```

Configuring Protocol-based VLANs

The network devices required to support multiple protocols cannot be easily grouped into a common VLAN. This may require non-standard devices to pass traffic between different VLANs in order to encompass all the devices participating in a specific protocol. This kind of configuration deprives users of the basic benefits of VLANs, including security and easy accessibility.

To avoid these problems, you can configure this switch with protocol-based VLANs that divide the physical network into logical VLAN groups for each required protocol. When a frame is received at a port, its VLAN membership can then be determined based on the protocol type in use by the inbound packets.

Table 4-20 Protocol-based VLAN Commands

Command	Function	Mode	Page
protocol-vlan protocol-group	Create a protocol group, specifying the supported protocols	GC	4-261
protocol-vlan protocol-group	Maps a protocol group to a VLAN	GC	4-262
show protocol-vlan protocol-group	Shows the configuration of protocol groups	PE	4-263
show protocol-vlan protocol-group-vid	Shows the mapping of protocol groups to VLAN	PE	4-263

To configure protocol-based VLANs, follow these steps:

1. First configure VLAN groups for the protocols you want to use (page 4-243). Although not mandatory, we suggest configuring a separate VLAN for each major protocol running on your network. Do not add port members at this time.
2. Create a protocol group for each of the protocols you want to assign to a VLAN using the **protocol-vlan protocol-group add** command.
3. Then map the protocol group to the appropriate VLAN using the **protocol-vlan protocol-group vlan** command.

Note: Traffic which matches IP Protocol Ethernet Frames is mapped to the VLAN (VLAN 1) that has been configured with the switch's administrative IP. IP Protocol Ethernet traffic must not be mapped to another VLAN or you will lose administrative network connectivity to the switch. If lost in this manner, network access can be regained by removing the offending Protocol VLAN rule via the console. Alternately, the switch can be power-cycled, however all unsaved configuration changes will be lost.

protocol-vlan protocol-group (Configuring Groups)

This command creates a protocol group. Only one frame and protocol type can be added to a protocol group. Use the **no** form to remove a protocol group.

Syntax

```
protocol-vlan protocol-group group-id [{add | remove} frame-type frame
protocol-type protocol]
no protocol-vlan protocol-group group-id
```

- *group-id* - Group identifier of this protocol group. (Range: 1-2147483647)
- *frame*¹ - Frame type used by this protocol. (Options: ethernet, rfc_1042, llc_other)
- *protocol* - Protocol type. The only option for the llc_other frame type is ipx_raw. The options for all other frames types include: ip, arp, and rarp.

Default Setting

No protocol groups are configured.

Command Mode

Global Configuration

Example

The following creates protocol group 2, and specifies Ethernet frames transmitting ARP protocol type traffic:

```
Console(config)#protocol-vlan protocol-group 2 add frame-type ethernet
  protocol-type arp
Console(config)#
```

protocol-vlan protocol-group (Configuring VLANs)

This command globally maps a protocol group to a VLAN. Use the **no** form to remove the protocol mapping.

Syntax

protocol-vlan protocol-group *group-id* **vlan** *vlan-id*
no protocol-vlan protocol-group *group-id* **vlan**

- *group-id* - Group identifier of this protocol group. (Range: 1-2147483647)
- *vlan-id* - VLAN to which matching protocol traffic is forwarded. (Range: 1-4092)

Default Setting

No protocol groups are mapped to any VLANs.

Command Mode

Global Configuration

Command Usage

- When creating a protocol-based VLAN, do not assign interfaces to the protocol VLAN via any of the standard VLAN commands. If you assign interfaces using any of the other VLAN commands (such as **vlan** on page 4-243), the switch will admit traffic of any protocol type into the associated VLAN.
- When a frame enters the switch that has protocol VLANs configured, it is processed in the following manner:
 - If the frame is tagged, it will be processed according to the standard rules

¹. SNAP frame types are not supported by this switch due to hardware limitations.

4 Command Line Interface

applied to tagged frames.

- If the frame is untagged and the protocol type matches, the frame is forwarded to the appropriate VLAN.
- If the frame is untagged but the protocol type does not match, the frame is forwarded to the default VLAN for the interface.

Example

The following example maps traffic matching the protocol type specified in protocol group 2 to VLAN 2.

```
Console(config)#protocol-vlan protocol-group 2 vlan 2
Console(config)#
```

show protocol-vlan protocol-group

This command shows the frame and protocol type associated with protocol groups.

Syntax

show protocol-vlan protocol-group [*group-id*]

group-id - Group identifier for a protocol group. (Range: 1-2147483647)

Default Setting

All protocol groups are displayed.

Command Mode

Privileged Exec

Example

This shows protocol group 2 configured for IP over RFC 1042:

```
Console#show protocol-vlan protocol-group

ProtocolGroup ID   Frame Type   Protocol Type
-----
                   2           RFC 1042    08 00
Console#
```

show protocol-vlan protocol-group-vid

This command shows the mapping from protocol groups to VLANs.

Syntax

show protocol-vlan protocol-group-vid

Default Setting

The mapping for all protocol groups is displayed.

Command Mode

Privileged Exec

Example

This shows that traffic matching the specifications for protocol group 2 will be mapped to VLAN 2:

```

Console#show protocol-vlan protocol-group-vid

ProtocolGroup ID   VLAN ID
-----
                   2           VLAN2
Console#

```

Priority Commands

The commands described in this section allow you to specify which data packets have greater precedence when traffic is buffered in the switch due to congestion. This switch supports CoS with four priority queues for each port. Data packets in a port's high-priority queue will be transmitted before those in the lower-priority queues. You can set the default priority for each interface, the relative weight of each queue, and the mapping of frame priority tags to the switch's priority queues.

Table 4-21 Priority Commands

Command Groups	Function	Page
Priority (Layer 2)	Configures default priority for untagged frames, sets queue weights, and maps class of service tags to hardware queues	4-264
Priority (Layer 3 and 4)	Maps IP DSCP tags to class of service values	4-269

Priority Commands (Layer 2)

Table 4-22 Priority Commands (Layer 2)

Command	Function	Mode	Page
queue mode	Sets the queue mode to strict priority or Weighted Round-Robin (WRR)	GC	4-265
switchport priority default	Sets a port priority for incoming untagged frames	IC	4-265
queue bandwidth	Assigns round-robin weights to the priority queues	GC	4-266
queue cos map	Assigns class-of-service values to the priority queues	IC	4-267
show queue mode	Shows the current queue mode	PE	4-268
show queue bandwidth	Shows round-robin weights assigned to the priority queues	PE	4-268
show queue cos-map	Shows the class-of-service map	PE	4-269
show interfaces switchport	Displays the administrative and operational status of an interface	PE	4-175

queue mode

This command sets the queue mode to strict priority or Weighted Round-Robin (WRR) for the class of service (CoS) priority queues. Use the **no** form to restore the default value.

Syntax

```
queue mode {strict | wrr}  
no queue mode
```

- **strict** - Services the egress queues in sequential order, transmitting all traffic in the higher priority queues before servicing lower priority queues.
- **wrr** - Weighted Round-Robin shares bandwidth at the egress ports by using scheduling weights 1, 2, 4, 8 for queues 0 - 3 respectively.

Default Setting

Weighted Round Robin

Command Mode

Global Configuration

Command Usage

You can set the switch to service the queues based on a strict rule that requires all traffic in a higher priority queue to be processed before lower priority queues are serviced, or use Weighted Round-Robin (WRR) queuing that specifies a relative weight of each queue. WRR uses a predefined relative weight for each queue that determines the percentage of service time the switch services each queue before moving on to the next queue. This prevents the head-of-line blocking that can occur with strict priority queuing.

Example

The following example sets the queue mode to strict priority service mode:

```
Console(config)#queue mode strict  
Console(config)#
```

switchport priority default

This command sets a priority for incoming untagged frames. Use the **no** form to restore the default value.

Syntax

```
switchport priority default default-priority-id  
no switchport priority default
```

default-priority-id - The priority number for untagged ingress traffic. The priority is a number from 0 to 7. Seven is the highest priority.

Default Setting

The priority is not set, and the default value for untagged frames received on the interface is zero.

Command Mode

Interface Configuration (Ethernet, Port Channel)

Command Usage

- The precedence for priority mapping is IP DSCP, and default switchport priority.
- The default priority applies for an untagged frame received on a port set to accept all frame types (i.e., receives both untagged and tagged frames). This priority does not apply to IEEE 802.1Q VLAN tagged frames. If the incoming frame is an IEEE 802.1Q VLAN tagged frame, the IEEE 802.1p User Priority bits will be used.
- This switch provides eight priority queues for each port. It is configured to use Weighted Round Robin, which can be viewed with the **show queue bandwidth** command. Inbound frames that do not have VLAN tags are tagged with the input port's default ingress user priority, and then placed in the appropriate priority queue at the output port. The default priority for all ingress ports is zero. Therefore, any inbound frames that do not have priority tags will be placed in queue 0 of the output port. (Note that if the output port is an untagged member of the associated VLAN, these frames are stripped of all VLAN tags prior to transmission.)

Example

The following example shows how to set a default priority on port 3 to 5:

```
Console(config)#interface ethernet 1/3
Console(config-if)#switchport priority default 5
```

queue bandwidth

This command assigns weighted round-robin (WRR) weights to the four class of service (CoS) priority queues. Use the **no** form to restore the default weights.

Note: This switch does not allow the queue service weights to be set. The weights are fixed as 1, 2, 4, 8, for queues 0 through 3 respectively.

Syntax

```
queue bandwidth weight1...weight4
no queue bandwidth
```

weight1...weight4 - The ratio of weights for queues 0-3 determines the weights used by the WRR scheduler. (Range: 1-31)

Default Setting

Weights 1, 2, 4, 8 are assigned to queues 0-3 respectively.

4 Command Line Interface

Command Mode

Global Configuration

Command Usage

WRR controls bandwidth sharing at the egress port by defining scheduling weights.

Example

This example shows how to assign WRR weights to priority queues 0 - 2:

```
Console(config)#queue bandwidth 6 9 12
Console(config)#
```

Related Commands

show queue bandwidth (4-268)

queue cos-map

This command assigns class of service (CoS) values to the priority queues (i.e., hardware output queues 0 - 3). Use the **no** form set the CoS map to the default values.

Syntax

queue cos-map *queue_id* [*cos1* ... *cosn*]

no queue cos-map

- *queue_id* - The ID of the priority queue.
Ranges are 0 to 3, where 3 is the highest priority queue.
- *cos1* .. *cosn* - The CoS values that are mapped to the queue ID. It is a space-separated list of numbers. The CoS value is a number from 0 to 7, where 7 is the highest priority.

Default Setting

This switch supports Class of Service by using four priority queues, with Weighted Round Robin queuing for each port. Eight separate traffic classes are defined in IEEE 802.1p. The default priority levels are assigned according to recommendations in the IEEE 802.1p standard as shown below.

Table 4-23 Default CoS Values to Egress Queues

Queue	0	1	2	3
Priority	1,2	0,3	4,5	6,7

Command Mode

Interface Configuration (Ethernet, Port Channel)

Command Usage

- CoS values assigned at the ingress port are also used at the egress port.
- This command sets the CoS priority for all interfaces.

Example

The following example shows how to change the CoS assignments:

```
Console(config)#interface ethernet 1/1
Console(config-if)#queue cos-map 0 0
Console(config-if)#queue cos-map 1 1
Console(config-if)#queue cos-map 2 2
Console(config-if)#exit
Console#show queue cos-map ethernet 1/1
Information of Eth 1/1
  Traffic Class : 0 1 2 3 4 5 6 7
  Priority Queue: 0 1 2 1 2 2 3 3
Console#
```

Related Commands

show queue cos-map (4-269)

show queue mode

This command shows the current queue mode.

Default Setting

None

Command Mode

Privileged Exec

Example

```
Console#show queue mode
Queue mode: wrr
Console#
```

show queue bandwidth

This command displays the weighted round-robin (WRR) bandwidth allocation for the four priority queues.

Default Setting

None

Command Mode

Privileged Exec

4 Command Line Interface

Example

```
Console#show queue bandwidth
Queue ID Weight
-----
0          1
1          2
2          4
3          8
Console#
```

show queue cos-map

This command shows the class of service priority map.

Syntax

show queue cos-map [*interface*]

interface

- **ethernet** *unit/port*
 - *unit* - Stack unit. (Range: 1)
 - *port* - Port number. (Range: 1-28/52)
- **port-channel** *channel-id* (Range: 1-8)

Default Setting

None

Command Mode

Privileged Exec

Example

```
Console#show queue cos-map ethernet 1/1
Information of Eth 1/1
Traffic Class : 0 1 2 3 4 5 6 7
Priority Queue: 1 0 0 1 2 2 3 3
Console#
```

Priority Commands (Layer 3 and 4)

Table 4-24 Priority Commands (Layer 3 and 4)

Command	Function	Mode	Page
map ip dscp	Enables IP DSCP class of service mapping	GC	4-269
map ip dscp	Maps IP DSCP value to a class of service	IC	4-270
show map ip dscp	Shows the IP DSCP map	PE	4-271

map ip dscp (Global Configuration)

This command enables IP DSCP mapping (i.e., Differentiated Services Code Point mapping). Use the **no** form to disable IP DSCP mapping.

Syntax

[no] map ip dscp

Default Setting

Disabled

Command Mode

Global Configuration

Command Usage

- The precedence for priority mapping is IP DSCP, and default switchport priority.

Example

The following example shows how to enable IP DSCP mapping globally:

```
Console(config)#map ip dscp
Console(config)#
```

map ip dscp (Interface Configuration)

This command sets IP DSCP priority (i.e., Differentiated Services Code Point priority). Use the **no** form to restore the default table.

Syntax

map ip dscp *dscp-value* **cos** *cos-value*

no map ip dscp

- *dscp-value* - 8-bit DSCP value. (Range: 0-63)
- *cos-value* - Class-of-Service value (Range: 0-7)

Default Setting

The DSCP default values are defined in the following table. Note that all the DSCP values that are not specified are mapped to CoS value 0.

Table 4-25 IP DSCP to CoS Values

IP DSCP Value	CoS Value
0	0
8	1
10, 12, 14, 16	2
18, 20, 22, 24	3
26, 28, 30, 32, 34, 36	4
38, 40, 42	5
48	6
46, 56	7

4 Command Line Interface

Command Mode

Interface Configuration (Ethernet, Port Channel)

Command Usage

- The precedence for priority mapping is IP DSCP, and default switchport priority.
- DSCP priority values are mapped to default Class of Service values according to recommendations in the IEEE 802.1p standard, and then subsequently mapped to the four hardware priority queues.
- This command sets the IP DSCP priority for all interfaces.

Example

The following example shows how to map IP DSCP value 1 to CoS value 0:

```
Console(config)#interface ethernet 1/5
Console(config-if)#map ip dscp 1 cos 0
Console(config-if)#
```

show map ip dscp

This command shows the IP DSCP priority map.

Syntax

show map ip dscp [*interface*]

interface

- **ethernet** *unit/port*
 - *unit* - Stack unit. (Range: 1)
 - *port* - Port number. (Range: 1-28/52)
- **port-channel** *channel-id* (Range: 1-8)

Default Setting

None

Command Mode

Privileged Exec

Example

```

Console#show map ip dscp ethernet 1/1
DSCP mapping status: disabled

  Port          DSCP  COS
  ----          -
Eth 1/ 1       0    0
Eth 1/ 1       1    0
Eth 1/ 1       2    0
Eth 1/ 1       3    0
:
:
Eth 1/ 1       61   0
Eth 1/ 1       62   0
Eth 1/ 1       63   0
Console#

```

Related Commands

- map ip dscp (Global Configuration) (4-269)
- map ip dscp (Interface Configuration) (4-270)

Quality of Service Commands

The commands described in this section are used to configure Differentiated Services (DiffServ) classification criteria and service policies. You can classify traffic based on access lists, IP Precedence or DSCP values, or VLANs. Using access lists allows you select traffic based on Layer 2, Layer 3, or Layer 4 information contained in each packet.

Table 4-26 Quality of Service Commands

Command	Function	Mode	Page
class-map	Creates a class map for a type of traffic	GC	4-273
match	Defines the criteria used to classify traffic	CM	4-274
policy-map	Creates a policy map for multiple interfaces	GC	4-275
class	Defines a traffic classification for the policy to act on	PM	4-276
set	Classifies IP traffic by setting a CoS, DSCP, or IP-precedence value in a packet	PM-C	4-277
police	Defines an enforcer for classified traffic	PM-C	4-277
service-policy	Applies a policy map defined by the policy-map command to the input of a particular interface	IC	4-278
show class-map	Displays the QoS class maps which define matching criteria used for classifying traffic	PE	4-279
show policy-map	Displays the QoS policy maps which define classification criteria for incoming traffic, and may include policers for bandwidth limitations	PE	4-279
show policy-map interface	Displays the configuration of all classes configured for all service policies on the specified interface	PE	4-280

To create a service policy for a specific category of ingress traffic, follow these steps:

1. Use the **class-map** command to designate a class name for a specific category of traffic, and enter the Class Map configuration mode.
2. Use the **match** command to select a specify type of traffic based on an access list, a DSCP or IP Precedence value, or a VLAN.
3. Set an ACL mask to enable filtering for the criteria specified in the **match** command.
4. Use the **policy-map** command to designate a policy name for a specific manner in which ingress traffic will be handled, and enter the Policy Map configuration mode.
5. Use the **class** command to identify the class map, and enter Policy Map Class configuration mode. A policy map can contain multiple class statements.
6. Use the **set** command to modify the QoS value for matching traffic class, and use the **policer** command to monitor the average flow and burst rate, and drop any traffic that exceeds the specified rate, or just reduce the DSCP service level for traffic exceeding the specified rate.
7. Use the **service-policy** command to assign a policy map to a specific interface.

- Notes:**
1. You can configure up to 16 rules per Class Map. You can also include multiple classes in a Policy Map.
 2. You should create a Class Map (page 4-273) before creating a Policy Map (page 4-275). Otherwise, you will not be able to specify a Class Map with the **class** command (page 4-276) after entering Policy-Map Configuration mode.

class-map

This command creates a class map used for matching packets to the specified class, and enters Class Map configuration mode. Use the **no** form to delete a class map and return to Global configuration mode.

Syntax

[no] class-map *class-map-name* [**match-any**]

- **match-any** - Match any condition within a class map.
- *class-map-name* - Name of the class map. (Range: 1-16 characters)

Default Setting

None

Command Mode

Global Configuration

Command Usage

- First enter this command to designate a class map and enter the Class Map configuration mode. Then use the **match** command (page 4-274) to specify the criteria for ingress traffic that will be classified under this class map.
- Up to 16 **match** commands are permitted per class map.

- The class map is used with a policy map (page 4-275) to create a service policy (page 4-278) for a specific interface that defines packet classification, service tagging, and bandwidth policing.

Example

This example creates a class map call “rd_class,” and sets it to match packets marked for DSCP service value 3:

```
Console(config)#class-map rd_class match-any
Console(config-cmap)#match ip dscp 3
Console(config-cmap)#
```

Related Commands

show class map (4-279)

match

This command defines the criteria used to classify traffic. Use the **no** form to delete the matching criteria.

Syntax

```
[no] match {access-list acl-name | ip dscp dscp | ip precedence
ip-precedence | vlan vlan}
```

- *acl-name* - Name of the access control list. Any type of ACL can be specified, including standard or extended IP ACLs and MAC ACLs. (Range: 1-16 characters)
- *dscp* - A DSCP value. (Range: 0-63)
- *ip-precedence* - An IP Precedence value. (Range: 0-7)
- *vlan* - A VLAN. (Range:1-4092)

Default Setting

None

Command Mode

Class Map Configuration

Command Usage

- First enter the **class-map** command to designate a class map and enter the Class Map configuration mode. Then use the **match** command to specify the fields within ingress packets that must match to qualify for this class map.
- Only one **match** command can be entered per class map.

Example

This example creates a class map called “rd_class#1,” and sets it to match packets marked for DSCP service value 3:

```
Console(config)#class-map rd_class#1_ match-any
Console(config-cmap)#match ip dscp 3
Console(config-cmap)#
```

4 Command Line Interface

This example creates a class map call “rd_class#2,” and sets it to match packets marked for IP Precedence service value 5:

```
Console(config)#class-map rd_class#2 match-any
Console(config-cmap)#match ip precedence 5
Console(config-cmap)#
```

This example creates a class map call “rd_class#3,” and sets it to match packets marked for VLAN 1:

```
Console(config)#class-map rd_class#3 match-any
Console(config-cmap)#match vlan 1
Console(config-cmap)#
```

policy-map

This command creates a policy map that can be attached to multiple interfaces, and enters Policy Map configuration mode. Use the **no** form to delete a policy map and return to Global configuration mode.

Syntax

[no] policy-map *policy-map-name*

policy-map-name - Name of the policy map. (Range: 1-16 characters)

Default Setting

None

Command Mode

Global Configuration

Command Usage

- Use the **policy-map** command to specify the name of the policy map, and then use the **class** command to configure policies for traffic that matches criteria defined in a class map.
- A policy map can contain multiple class statements that can be applied to the same interface with the **service-policy** command (page 4-278).
- You must create a Class Map (page 4-275) before assigning it to a Policy Map.

Example

This example creates a policy called “rd_policy,” uses the **class** command to specify the previously defined “rd_class,” uses the **set** command to classify the service that incoming packets will receive, and then uses the **police** command to limit the average bandwidth to 100,000 Kbps, the burst rate to 1522 bytes, and configure the response to drop any violating packets.

```
Console(config)#policy-map rd_policy
Console(config-pmap)#class rd_class
Console(config-pmap-c)#set ip dscp 3
Console(config-pmap-c)#police 100000 1522 exceed-action drop
Console(config-pmap-c)#
```

class

This command defines a traffic classification upon which a policy can act, and enters Policy Map Class configuration mode. Use the **no** form to delete a class map and return to Policy Map configuration mode.

Syntax

[no] class *class-map-name*

class-map-name - Name of the class map. (Range: 1-16 characters)

Default Setting

None

Command Mode

Policy Map Configuration

Command Usage

- Use the **policy-map** command to specify a policy map and enter Policy Map configuration mode. Then use the **class** command to enter Policy Map Class configuration mode. And finally, use the **set** and **police** commands to specify the match criteria, where the:
 - **set** command classifies the service that an IP packet will receive.
 - **police** command defines the maximum throughput, burst rate, and the action that results from a policy violation.
- You can configure up to 16 rules per Class Map. You can also include multiple classes in a Policy Map.

Example

This example creates a policy called "rd_policy," uses the **class** command to specify the previously defined "rd_class," uses the **set** command to classify the service that incoming packets will receive, and then uses the **police** command to limit the average bandwidth to 100,000 Kbps, the burst rate to 1522 bytes, and configure the response to drop any violating packets.

```
Console(config)#policy-map rd_policy
Console(config-pmap)#class rd_class
Console(config-pmap-c)#set ip dscp 3
Console(config-pmap-c)#police 100000 1522 exceed-action drop
Console(config-pmap-c)#
```

set

This command services IP traffic by setting a CoS, DSCP, or IP Precedence value in a matching packet (as specified by the **match** command on page 4-274). Use the **no** form to remove the traffic classification.

Syntax

```
[no] set {cos new-cos | ip dscp new-dscp | ip precedence new-precedence |  
ipv6 dscp new-dscp}
```

- *new-cos* - New Class of Service (CoS) value. (Range: 0-7)
- *new-dscp* - New Differentiated Service Code Point (DSCP) value. (Range: 0-63)
- *new-precedence* - New IP Precedence value. (Range: 0-7)

Default Setting

None

Command Mode

Policy Map Class Configuration

Example

This example creates a policy called "rd_policy," uses the **class** command to specify the previously defined "rd_class," uses the **set** command to classify the service that incoming packets will receive, and then uses the **police** command to limit the average bandwidth to 100,000 Kbps, the burst rate to 1522 bytes, and configure the response to drop any violating packets.

```
Console(config)#policy-map rd_policy  
Console(config-pmap)#class rd_class  
Console(config-pmap-c)#set ip dscp 3  
Console(config-pmap-c)#police 100000 1522 exceed-action drop  
Console(config-pmap-c)#
```

police

This command defines an policer for classified traffic. Use the **no** form to remove a policer.

Syntax

```
[no] police rate-kbps burst-byte [exceed-action {drop | set}]
```

- *rate-kbps* - Rate in kilobits per second. (Range: 1-100000 kbps or maximum port speed, whichever is lower)
- *burst-byte* - Burst in bytes. (Range: 64-1522 bytes)
- **drop** - Drop packet when specified rate or burst are exceeded.
- **set** - Set DSCP service to the specified value. (Range: 0-63)

Default Setting

Drop out-of-profile packets.

Command Mode

Policy Map Class Configuration

Command Usage

- You can configure up to 64 policers (i.e., meters or class maps) for each of the following access list types: MAC ACL, IP ACL (including Standard ACL and Extended ACL), IPv6 Standard ACL, and IPv6 Extended ACL. This limitation applies to each switch chip (TL-SL5428: ports 1-28; TL-SL5452: ports 1-28, ports 29-52).
- Policing is based on a token bucket, where bucket depth (i.e., the maximum burst before the bucket overflows) is specified by the *burst-byte* field, and the average rate at which tokens are removed from the bucket is specified by the *rate-bps* option.

Example

This example creates a policy called “rd_policy,” uses the **class** command to specify the previously defined “rd_class,” uses the **set** command to classify the service that incoming packets will receive, and then uses the **police** command to limit the average bandwidth to 100,000 Kbps, the burst rate to 1522 bytes, and configure the response to drop any violating packets.

```
Console(config)#policy-map rd_policy
Console(config-pmap)#class rd_class
Console(config-pmap-c)#set ip dscp 3
Console(config-pmap-c)#police 100000 1522 exceed-action drop
Console(config-pmap-c)#
```

service-policy

This command applies a policy map defined by the **policy-map** command to the ingress queue of a particular interface. Use the **no** form to remove the policy map from this interface.

Syntax

[no] **service-policy** input *policy-map-name*

- **input** - Apply to the input traffic.
- *policy-map-name* - Name of the policy map for this interface.
(Range: 1-16 characters)

Default Setting

No policy map is attached to an interface.

Command Mode

Interface Configuration (Ethernet, Port Channel)

Command Usage

- You can only assign one policy map to an interface.
- You must first define a class map, then define a policy map, and finally use the **service-policy** command to bind the policy map to the required interface.

4 Command Line Interface

Example

This example applies a service policy to an ingress interface.

```
Console(config)#interface ethernet 1/1
Console(config-if)#service-policy input rd_policy
Console(config-if)#
```

show class-map

This command displays the QoS class maps which define matching criteria used for classifying traffic.

Syntax

show class-map [*class-map-name*]

class-map-name - Name of the class map. (Range: 1-16 characters)

Default Setting

Displays all class maps.

Command Mode

Privileged Exec

Example

```
Console#show class-map
Class Map match-any rd_class#1
Match ip dscp 3

Class Map match-any rd_class#2
Match ip precedence 5

Class Map match-any rd_class#3
Match vlan 1

Console#
```

show policy-map

This command displays the QoS policy maps which define classification criteria for incoming traffic, and may include policers for bandwidth limitations.

Syntax

show policy-map [*policy-map-name* [*class class-map-name*]]

- *policy-map-name* - Name of the policy map. (Range: 1-16 characters)
- *class-map-name* - Name of the class map. (Range: 1-16 characters)

Default Setting

Displays all policy maps and all classes.

Command Mode

Privileged Exec

Example

```

Console#show policy-map
Policy Map rd_policy
  class rd_class
    set ip dscp 3
Console#show policy-map rd_policy class rd_class
Policy Map rd_policy
  class rd_class
    set ip dscp 3
Console#

```

show policy-map interface

This command displays the service policy assigned to the specified interface.

Syntax

show policy-map interface *interface* **input**

interface

- **ethernet** *unit/port*
 - *unit* - Stack unit. (Range: 1)
 - *port* - Port number. (Range: 1-28/52)
- **port-channel** *channel-id* (Range: 1-8)

Command Mode

Privileged Exec

Example

```

Console#show policy-map interface ethernet 1/5
Service-policy rd_policy input
Console#

```

Voice VLAN Commands

The switch allows you to specify a Voice VLAN for the network and set a CoS priority for the VoIP traffic. VoIP traffic can be detected on switch ports by using the source MAC address of packets, or by using LLDP (IEEE 802.1AB) to discover connected VoIP devices. When VoIP traffic is detected on a configured port, the switch automatically assigns the port to the Voice VLAN. Alternatively, switch ports can be manually configured.

Table 4-27 Voice VLAN Commands

Command	Function	Mode	Page
voice vlan	Defines the Voice VLAN ID	GC	4-281
voice vlan aging	Configures the aging time for Voice VLAN ports	GC	4-282
voice vlan mac-address	Configures VoIP device MAC addresses	GC	4-282
switchport voice vlan	Sets the Voice VLAN port mode	IC	4-283
switchport voice vlan rule	Sets the automatic VoIP traffic detection method for ports	IC	4-284

Table 4-27 Voice VLAN Commands

Command	Function	Mode	Page
switchport voice vlan security	Enables Voice VLAN security on ports	IC	4-284
switchport voice vlan priority	Sets the VoIP traffic priority for ports	IC	4-285
show voice vlan	Displays Voice VLAN settings	PE	4-286

voice vlan

This command enables VoIP traffic detection and defines the Voice VLAN ID. Use the **no** form to disable the Voice VLAN.

Syntax

```
voice vlan voice-vlan-id  
no voice vlan
```

voice-vlan-id - Specifies the voice VLAN ID. (Range: 1-4094)

Default Setting

Disabled

Command Mode

Global Configuration

Command Usage

- When IP telephony is deployed in an enterprise network, it is recommended to isolate the Voice over IP (VoIP) network traffic from other data traffic. Traffic isolation helps prevent excessive packet delays, packet loss, and jitter, which results in higher voice quality. This is best achieved by assigning all VoIP traffic to a single VLAN.
- VoIP traffic can be detected on switch ports by using the source MAC address of packets, or by using LLDP (IEEE 802.1AB) to discover connected VoIP devices. When VoIP traffic is detected on a configured port, the switch automatically assigns the port as a tagged member of the Voice VLAN.
- Only one Voice VLAN is supported and it must already be created on the switch before it can be specified as the Voice VLAN.
- The Voice VLAN ID cannot be modified when the global auto-detection status is enabled.

Example

The following example enables VoIP traffic detection and specifies the Voice VLAN ID as 1234.

```
Console(config)#voice vlan 1234  
Console(config)#
```

voice vlan aging

This command sets the Voice VLAN ID time out. Use the **no** form to restore the default.

Syntax

```
voice vlan aging minutes  
no voice vlan
```

minutes - Specifies the port Voice VLAN membership time out.
(Range: 5-43200 minutes)

Default Setting

1440 minutes

Command Mode

Global Configuration

Command Usage

The Voice VLAN aging time is the time after which a port is removed from the Voice VLAN when VoIP traffic is no longer received on the port.

Example

The following example configures the Voice VLAN aging time as 3000 minutes.

```
Console(config)#voice vlan aging 3000  
Console(config)#
```

voice vlan mac-address

This command specifies MAC address ranges to add to the OUI Telephony list. Use the **no** form to remove an entry from the list.

Syntax

```
voice vlan mac-address mac-address mask mask-address [description  
description]  
no voice vlan mac-address mac-address mask mask-address
```

- *mac-address* - Defines a MAC address OUI that identifies VoIP devices in the network. (For example, 01-23-45-00-00-00)
- *mask-address* - Identifies a range of MAC addresses. (Range: 80-00-00-00-00-00 to FF-FF-FF-FF-FF-FF)
- *description* - User-defined text that identifies the VoIP devices.

Default Setting

None

Command Mode

Global Configuration

Command Usage

- VoIP devices attached to the switch can be identified by the manufacturer's Organizational Unique Identifier (OUI) in the source MAC address of received packets. OUI numbers are assigned to manufacturers and form the first three octets of device MAC addresses. The MAC OUI numbers for VoIP equipment can be configured on the switch so that traffic from these devices is recognized as VoIP.
- Selecting a mask of FF-FF-FF-00-00-00 identifies all devices with the same OUI (the first three octets). Other masks restrict the MAC address range. Selecting FF-FF-FF-FF-FF-FF specifies a single MAC address.

Example

The following example adds a MAC OUI to the OUI Telephony list.

```
Console(config)#voice vlan mac-address 00-12-34-56-78-90 mask
ff-ff-ff-00-00-00 description A new phone
Console(config)#
```

switchport voice vlan

This command specifies the Voice VLAN mode for ports. Use the **no** form to disable the Voice VLAN feature on the port.

Syntax

```
switchport voice vlan {manual | auto}
no switchport voice vlan
```

- **manual** - The Voice VLAN feature is enabled on the port, but the port must be manually added to the Voice VLAN.
- **auto** - The port will be added as a tagged member to the Voice VLAN when VoIP traffic is detected on the port.

Default Setting

Disabled

Command Mode

Interface Configuration

Command Usage

When **auto** is selected, you must select the method to use for detecting VoIP traffic, either OUI or 802.1ab (LLDP). When OUI is selected, be sure to configure the MAC address ranges in the Telephony OUI list.

Example

The following example sets port 1 to Voice VLAN auto mode.

```
Console(config)#interface ethernet 1/1
Console(config-if)#switchport voice vlan auto
Console(config-if)#
```

switchport voice vlan rule

This command selects a method for detecting VoIP traffic on a port. Use the **no** form to disable the detection method on the port.

Syntax

[no] switchport voice vlan rule {oui | lldp}

- **oui** - Traffic from VoIP devices is detected by the Organizationally Unique Identifier (OUI) of the source MAC address.
- **lldp** - Uses LLDP to discover VoIP devices attached to the port.

Default Setting

OUI: Enabled
LLDP: Disabled

Command Mode

Interface Configuration

Command Usage

- When OUI is selected, be sure to configure the MAC address ranges in the Telephony OUI list. MAC address OUI numbers must be configured in the Telephony OUI list so that the switch recognizes the traffic as being from a VoIP device.
- LLDP checks that the “telephone bit” in the system capability TLV is turned on. See “LLDP Commands” on page 4-193 for more information on LLDP.

Example

The following example enables the OUI method on port 1 for detecting VoIP traffic.

```
Console(config)#interface ethernet 1/1
Console(config-if)#switchport voice vlan rule oui
Console(config-if)#
```

switchport voice vlan security

This command enables security filtering for VoIP traffic on a port. Use the **no** form to disable filtering on a port.

Syntax

[no] switchport voice vlan security

Default Setting

Disabled

Command Mode

Interface Configuration

Command Usage

- Security filtering discards any non-VoIP packets received on the port that are tagged with voice VLAN ID. VoIP traffic is identified by source MAC addresses configured in the Telephony OUI list, or through LLDP that discovers VoIP devices attached to the switch. Packets received from non-VoIP sources are dropped.
- When enabled, be sure the MAC address ranges for VoIP devices are configured in the Telephony OUI list.

Example

The following example enables security filtering on port 1.

```
Console(config)#interface ethernet 1/1
Console(config-if)#switchport voice vlan security
Console(config-if)#
```

switchport voice vlan priority

This command specifies a CoS priority for VoIP traffic on a port. Use the **no** form to restore the default priority on a port.

Syntax

switchport voice vlan priority *priority-value*
no switchport voice vlan priority

- *priority-value* - The CoS priority value. (Range: 0-6)

Default Setting

6

Command Mode

Interface Configuration

Command Usage

Specifies a CoS priority to apply to the port VoIP traffic on the Voice VLAN. The priority of any received VoIP packet is overwritten with the new priority when the Voice VLAN feature is active for the port.

Example

The following example sets the CoS priority to 5 on port 1.

```
Console(config)#interface ethernet 1/1
Console(config-if)#switchport voice vlan priority 5
Console(config-if)#
```

show voice vlan

This command displays the Voice VLAN settings on the switch and the OUI Telephony list.

Syntax

show voice vlan {oui | status}

- **oui** - Displays the OUI Telephony list.
- **status** - Displays the global and port Voice VLAN settings.

Default Setting

None

Command Mode

Privileged Exec

Example

```

Console#show voice vlan status
Global Voice VLAN Status
Voice VLAN Status      : Enabled
Voice VLAN ID         : 1234
Voice VLAN aging time : 1440 minutes

Voice VLAN Port Summary
Port      Mode      Security Rule      Priority
-----
Eth 1/ 1 Auto      Enabled OUI                6
Eth 1/ 2 Disabled Disabled OUI                6
Eth 1/ 3 Manual   Enabled OUI                5
Eth 1/ 4 Auto      Enabled OUI                6
Eth 1/ 5 Disabled Disabled OUI                6
Eth 1/ 6 Disabled Disabled OUI                6
Eth 1/ 7 Disabled Disabled OUI                6
Eth 1/ 8 Disabled Disabled OUI                6
Eth 1/ 9 Disabled Disabled OUI                6
Eth 1/10 Disabled Disabled OUI                6

Console#show voice vlan oui
OUIAddress      Mask      Description
00-12-34-56-78-9A FF-FF-FF-00-00-00 old phones
00-11-22-33-44-55 FF-FF-FF-00-00-00 new phones
00-98-76-54-32-10 FF-FF-FF-FF-FF-FF Chris' phone

Console#

```

Multicast Filtering Commands

This switch uses IGMP (Internet Group Management Protocol) to query for any attached hosts that want to receive a specific multicast service. It identifies the ports containing hosts requesting a service and sends data out to those ports only. It then propagates the service request up to any neighboring multicast switch/router to ensure that it will continue to receive the multicast service.

Table 4-28 Multicast Filtering Commands

Command Groups	Function	Page
IGMP Snooping	Configures multicast groups via IGMP snooping or static assignment, sets the IGMP version, displays current snooping and query settings, and displays the multicast service and group members	4-287
IGMP Query	Configures IGMP query parameters for multicast filtering at Layer 2	4-292
Static Multicast Routing	Configures static multicast router ports	4-295
IGMP Filtering and Throttling	Configures IGMP filtering and throttling	4-297
Multicast VLAN Registration	Configures a single network-wide multicast VLAN shared by hosts residing in other standard or private VLAN groups, preserving security and data isolation for normal traffic	4-304

IGMP Snooping Commands

This section describes commands used to configure IGMP snooping on the switch.

Table 4-29 IGMP Snooping Commands

Command	Function	Mode	Page
ip igmp snooping	Enables IGMP snooping	GC	4-288
ip igmp snooping vlan static	Adds an interface as a member of a multicast group	GC	4-288
ip igmp snooping version	Configures the IGMP version for snooping	GC	4-289
ip igmp snooping leave-proxy	Enables IGMP leave proxy on the switch	GC	4-289
ip igmp snooping immediate-leave	Enables IGMP immediate leave for a VLAN interface	IC	4-290
show ip igmp snooping	Shows the IGMP snooping and query configuration	PE	4-289
show mac-address-table multicast	Shows the IGMP snooping MAC multicast list	PE	4-291

ip igmp snooping

This command enables IGMP snooping on this switch. Use the **no** form to disable it.

Syntax

[no] ip igmp snooping

Default Setting

Enabled

Command Mode

Global Configuration

Example

The following example enables IGMP snooping.

```
Console(config)#ip igmp snooping
Console(config)#
```

ip igmp snooping vlan static

This command adds a port to a multicast group. Use the **no** form to remove the port.

Syntax

[no] ip igmp snooping vlan *vlan-id* static *ip-address* interface

- *vlan-id* - VLAN ID (Range: 1-4092)
- *ip-address* - IP address for multicast group
- *interface*
 - **ethernet** *unit/port*
 - *unit* - Stack unit. (Range: 1)
 - *port* - Port number. (Range: 1-28/52)
 - **port-channel** *channel-id* (Range: 1-8)

Default Setting

None

Command Mode

Global Configuration

Example

The following shows how to statically configure a multicast group on a port:

```
Console(config)#ip igmp snooping vlan 1 static 224.0.0.12 ethernet 1/5
Console(config)#
```

ip igmp snooping version

This command configures the IGMP snooping version. Use the **no** form to restore the default.

Syntax

```
ip igmp snooping version {1 | 2 | 3}  
no ip igmp snooping version
```

- **1** - IGMP Version 1
- **2** - IGMP Version 2
- **3** - IGMP Version 3

Default Setting

IGMP Version 2

Command Mode

Global Configuration

Command Usage

- All systems on the subnet must support the same version. If there are legacy devices in your network that only support Version 1, you will also have to configure this switch to use Version 1.
- Some commands are only enabled for IGMPv2 and/or v3, including **ip igmp snooping querier**, **ip igmp snooping query-max-response-time**, **ip igmp snooping query-interval**, and **ip igmp snooping immediate leave**.

Example

The following configures the switch to use IGMP Version 1:

```
Console(config)#ip igmp snooping version 1  
Console(config)#
```

ip igmp snooping leave-proxy

This command enables IGMP leave proxy on the switch. Use the **no** form to disable the feature.

Syntax

```
[no] ip igmp snooping leave-proxy
```

Default Setting

Disabled

Command Mode

Global Configuration

Command Usage

- The IGMP snooping leave-proxy feature suppresses all unnecessary IGMP leave messages so that the non-querier switch forwards an IGMP leave packet only when the last dynamic member port leaves a multicast group.
- The leave-proxy feature does not function when a switch is set as the querier.

Example

```
Console(config)#ip igmp snooping leave-proxy
Console(config)#
```

ip igmp snooping immediate-leave

This command immediately deletes a member port of a multicast service if a leave packet is received at that port and immediate-leave is enabled for the parent VLAN. Use the **no** form to restore the default.

Syntax

```
[no] ip igmp snooping immediate-leave vlan-id
      vlan-id - VLAN ID (1 to 4092)
```

Default Setting

Disabled

Command Mode

Interface Configuration (VLAN)

Command Usage

- If immediate-leave is *not* used, a multicast router (or querier) will send a group-specific query message when an IGMPv2 or IGMPv3 group leave message is received. The router/querier stops forwarding traffic for that group only if no host replies to the query within the specified timeout period. Note that the timeout period is determined by **ip igmp snooping query-max-response-time** (see 4-294).
- If immediate-leave is enabled, the switch assumes that only one host is connected to the interface. Therefore, immediate leave should only be enabled on an interface if it is connected to only one IGMP-enabled device, either a service host or a neighbor running IGMP snooping.
- This command is only effective if IGMP snooping is enabled, and IGMPv2 or IGMPv3 snooping is used.

Example

The following shows how to enable immediate leave.

```
Console(config)#interface vlan 1
Console(config-if)#ip igmp snooping immediate-leave
Console(config-if)#
```

show ip igmp snooping

This command shows the IGMP snooping configuration.

Default Setting

None

Command Mode

Privileged Exec

Command Usage

See “Configuring IGMP Snooping and Query Parameters” on page 3-215 for a description of the displayed items.

Example

The following shows the current IGMP snooping configuration:

```
Console#show ip igmp snooping
Service status:           Enabled
Querier status:          Enabled
Leave proxy status:       Disabled
Query count:              10
Query interval:          100 sec
Query max response time: 20 sec
Router port expire time: 300 sec
Immediate Leave Processing: Disabled on all VLAN
IGMP snooping version:   Version 2
Console#
```

show mac-address-table multicast

This command shows known multicast addresses.

Syntax

```
show mac-address-table multicast [vlan vlan-id] [user | igmp-snooping]
```

- *vlan-id* - VLAN ID (1 to 4092)
- **user** - Display only the user-configured multicast entries.
- **igmp-snooping** - Display only entries learned through IGMP snooping.

Default Setting

None

Command Mode

Privileged Exec

Command Usage

Member types displayed include IGMP or USER, depending on selected options.

Example

The following shows the multicast entries learned through IGMP snooping for VLAN 1:

```

Console#show mac-address-table multicast vlan 1 igmp-snooping
VLAN M'cast IP addr. Member ports Type
-----
  1      224.1.1.2.3      Eth1/11      IGMP
Console#

```

IGMP Query Commands (Layer 2)

This section describes commands used to configure Layer 2 IGMP query on the switch.

Table 4-30 IGMP Query Commands (Layer 2)

Command	Function	Mode	Page
ip igmp snooping querier	Allows this device to act as the querier for IGMP snooping	GC	4-292
ip igmp snooping query-count	Configures the query count	GC	4-293
ip igmp snooping query-interval	Configures the query interval	GC	4-293
ip igmp snooping query-max-response-time	Configures the report delay	GC	4-294
ip igmp snooping router-port-expire-time	Configures the query timeout	GC	4-295

ip igmp snooping querier

This command enables the switch as an IGMP querier. Use the **no** form to disable it.

Syntax

[no] ip igmp snooping querier

Default Setting

Enabled

Command Mode

Global Configuration

Command Usage

- IGMP snooping querier is not supported for IGMPv3 snooping (see **ip igmp snooping version**, page 4-289).
- If enabled, the switch will serve as querier if elected. The querier is responsible for asking hosts if they want to receive multicast traffic.

Example

```
Console(config)#ip igmp snooping querier
Console(config)#
```

ip igmp snooping query-count

This command configures the query count. Use the **no** form to restore the default.

Syntax

```
ip igmp snooping query-count count
no ip igmp snooping query-count
```

count - The maximum number of queries issued for which there has been no response before the switch takes action to drop a client from the multicast group. (Range: 2-10)

Default Setting

2 times

Command Mode

Global Configuration

Command Usage

The query count defines how long the querier waits for a response from a multicast client before taking action. If a querier has sent a number of queries defined by this command, but a client has not responded, a countdown timer is started using the time defined by **ip igmp snooping query-max-response-time**. If the countdown finishes, and the client still has not responded, then that client is considered to have left the multicast group.

Example

The following shows how to configure the query count to 10:

```
Console(config)#ip igmp snooping query-count 10
Console(config)#
```

Related Commands

ip igmp snooping query-max-response-time (4-294)

ip igmp snooping query-interval

This command configures the query interval. Use the **no** form to restore the default.

Syntax

```
ip igmp snooping query-interval seconds
no ip igmp snooping query-interval
```

seconds - The frequency at which the switch sends IGMP host-query messages. (Range: 60-125)

Default Setting

125 seconds

Command Mode

Global Configuration

Example

The following shows how to configure the query interval to 100 seconds:

```
Console(config)#ip igmp snooping query-interval 100
Console(config)#
```

ip igmp snooping query-max-response-time

This command configures the query report delay. Use the **no** form to restore the default.

Syntax

ip igmp snooping query-max-response-time *seconds*
no ip igmp snooping query-max-response-time

seconds - The report delay advertised in IGMP queries. (Range: 5-25)

Default Setting

10 seconds

Command Mode

Global Configuration

Command Usage

- The switch must be using IGMPv2 or v3 snooping for this command to take effect.
- This command defines the time after a query, during which a response is expected from a multicast client. If a querier has sent a number of queries defined by the **ip igmp snooping query-count**, but a client has not responded, a countdown timer is started using an initial value set by this command. If the countdown finishes, and the client still has not responded, then that client is considered to have left the multicast group.

Example

The following shows how to configure the maximum response time to 20 seconds:

```
Console(config)#ip igmp snooping query-max-response-time 20
Console(config)#
```

Related Commands

ip igmp snooping version (4-289)

ip igmp snooping router-port-expire-time

This command configures the query timeout. Use the **no** form to restore the default.

Syntax

ip igmp snooping router-port-expire-time *seconds*
no ip igmp snooping router-port-expire-time

seconds - The time the switch waits after the previous querier stops before it considers the router port (i.e., the interface which had been receiving query packets) to have expired.
(Range: 300-500)

Default Setting

300 seconds

Command Mode

Global Configuration

Command Usage

The switch must use IGMPv2 or v3 snooping for this command to take effect.

Example

The following shows how to configure the default timeout to 300 seconds:

```
Console(config)#ip igmp snooping router-port-expire-time 300
Console(config)#
```

Related Commands

ip igmp snooping version (4-289)

Static Multicast Routing Commands

This section describes commands used to configure static multicast routing on the switch.

Table 4-31 Static Multicast Routing Commands

Command	Function	Mode	Page
ip igmp snooping vlan mrouter	Adds a multicast router port	GC	4-296
show ip igmp snooping mrouter	Shows multicast router ports	PE	4-296

ip igmp snooping vlan mrouter

This command statically configures a multicast router port. Use the **no** form to remove the configuration.

Syntax

[no] **ip igmp snooping vlan** *vlan-id* **mrouter** *interface*

- *vlan-id* - VLAN ID (Range: 1-4092)
- *interface*
 - **ethernet** *unit/port*
 - *unit* - Stack unit. (Range: 1)
 - *port* - Port number. (Range: 1-28/52)
 - **port-channel** *channel-id* (Range: 1-8)

Default Setting

No static multicast router ports are configured.

Command Mode

Global Configuration

Command Usage

Depending on your network connections, IGMP snooping may not always be able to locate the IGMP querier. Therefore, if the IGMP querier is a known multicast router/switch connected over the network to an interface (port or trunk) on your router, you can manually configure that interface to join all the current multicast groups.

Example

The following shows how to configure port 11 as a multicast router port within VLAN 1:

```
Console(config)#ip igmp snooping vlan 1 mrouter ethernet 1/11
Console(config)#
```

show ip igmp snooping mrouter

This command displays information on statically configured and dynamically learned multicast router ports.

Syntax

show ip igmp snooping mrouter [**vlan** *vlan-id*]

vlan-id - VLAN ID (Range: 1-4092)

Default Setting

Displays multicast router ports for all configured VLANs.

Command Mode

Privileged Exec

Command Usage

Multicast router port types displayed include Static.

Example

The following shows that port 11 in VLAN 1 is attached to a multicast router:

```

Console#show ip igmp snooping mrouter vlan 1
VLAN M'cast Router Ports Type
-----
 1                Eth 1/11  Static
 2                Eth 1/12  Static
Console#

```

IGMP Filtering and Throttling Commands

In certain switch applications, the administrator may want to control the multicast services that are available to end users. For example, an IP/TV service based on a specific subscription plan. The IGMP filtering feature fulfills this requirement by restricting access to specified multicast services on a switch port, and IGMP throttling limits the number of simultaneous multicast groups a port can join.

Table 4-32 IGMP Filtering and Throttling Commands

Command	Function	Mode	Page
ip igmp filter	Enables IGMP filtering and throttling on the switch	GC	4-298
ip igmp profile	Sets a profile number and enters IGMP filter profile configuration mode	GC	4-298
permit, deny	Sets a profile access mode to permit or deny	IPC	4-299
range	Specifies one or a range of multicast addresses for a profile	IPC	4-299
ip igmp filter	Assigns an IGMP filter profile to an interface	IC	4-300
ip igmp max-groups	Specifies an IGMP throttling number for an interface	IC	4-300
ip igmp max-groups action	Sets the IGMP throttling action for an interface	IC	4-301
show ip igmp filter	Displays the IGMP filtering status	PE	4-302
show ip igmp profile	Displays IGMP profiles and settings	PE	4-302
show ip igmp throttle interface	Displays the IGMP throttling setting for interfaces	PE	4-303

ip igmp filter (Global Configuration)

This command globally enables IGMP filtering and throttling on the switch. Use the **no** form to disable the feature.

Syntax

[no] ip igmp filter

Default Setting

Disabled

Command Mode

Global Configuration

Command Usage

- IGMP filtering enables you to assign a profile to a switch port that specifies multicast groups that are permitted or denied on the port. An IGMP filter profile can contain one or more, or a range of multicast addresses; but only one profile can be assigned to a port. When enabled, IGMP join reports received on the port are checked against the filter profile. If a requested multicast group is permitted, the IGMP join report is forwarded as normal. If a requested multicast group is denied, the IGMP join report is dropped.
- IGMP filtering and throttling only applies to dynamically learned multicast groups, it does not apply to statically configured groups.
- The IGMP filtering feature operates in the same manner when MVR is used to forward multicast traffic.

Example

```
Console(config)#ip igmp filter
Console(config)#
```

ip igmp profile

This command creates an IGMP filter profile number and enters IGMP profile configuration mode. Use the **no** form to delete a profile number.

Syntax

[no] ip igmp profile *profile-number*

profile-number - An IGMP filter profile number. (Range: 1-4294967295)

Default Setting

Disabled

Command Mode

Global Configuration

4 Command Line Interface

Command Usage

A profile defines the multicast groups that a subscriber is permitted or denied to join. The same profile can be applied to many interfaces, but only one profile can be assigned to one interface. Each profile has only one access mode; either permit or deny.

Example

```
Console(config)#ip igmp profile 19
Console(config-igmp-profile)#
```

permit, deny

This command sets the access mode for an IGMP filter profile. Use the **no** form to delete a profile number.

Syntax

{**permit** | **deny**}

Default Setting

Deny

Command Mode

IGMP Profile Configuration

Command Usage

- Each profile has only one access mode; either permit or deny.
- When the access mode is set to permit, IGMP join reports are processed when a multicast group falls within the controlled range. When the access mode is set to deny, IGMP join reports are only processed when a multicast group is not in the controlled range.

Example

```
Console(config)#ip igmp profile 19
Console(config-igmp-profile)#permit
Console(config-igmp-profile)#
```

range

This command specifies multicast group addresses for a profile. Use the **no** form to delete addresses from a profile.

Syntax

[**no**] **range** *low-ip-address* [*high-ip-address*]

- *low-ip-address* - A valid IP address of a multicast group or start of a group range.
- *high-ip-address* - A valid IP address for the end of a multicast group range.

Default Setting

None

Command Mode

IGMP Profile Configuration

Command Usage

Enter this command multiple times to specify more than one multicast address or address range for a profile.

Example

```
Console(config)#ip igmp profile 19
Console(config-igmp-profile)#range 239.1.1.1
Console(config-igmp-profile)#range 239.2.3.1 239.2.3.100
Console(config-igmp-profile)#
```

ip igmp filter (Interface Configuration)

This command assigns an IGMP filtering profile to an interface on the switch. Use the **no** form to remove a profile from an interface.

Syntax

[no] ip igmp filter profile-number

profile-number - An IGMP filter profile number. (Range: 1-4294967295)

Default Setting

None

Command Mode

Interface Configuration

Command Usage

- The IGMP filtering profile must first be created with the **ip igmp profile** command before being able to assign it to an interface.
- Only one profile can be assigned to an interface.
- A profile can also be assigned to a trunk interface. When ports are configured as trunk members, the trunk uses the filtering profile assigned to the first port member in the trunk.

Example

```
Console(config)#interface ethernet 1/1
Console(config-if)#ip igmp filter 19
Console(config-if)#
```

ip igmp max-groups

This command sets the IGMP throttling number for an interface on the switch. Use the **no** form to restore the default setting.

Syntax

ip igmp max-groups number
no ip igmp max-groups

4 Command Line Interface

number - The maximum number of multicast groups an interface can join at the same time. (Range: 0-64)

Default Setting

64

Command Mode

Interface Configuration

Command Usage

- IGMP throttling sets a maximum number of multicast groups that a port can join at the same time. When the maximum number of groups is reached on a port, the switch can take one of two actions; either “deny” or “replace.” If the action is set to deny, any new IGMP join reports will be dropped. If the action is set to replace, the switch randomly removes an existing group and replaces it with the new multicast group.
- IGMP throttling can also be set on a trunk interface. When ports are configured as trunk members, the trunk uses the throttling settings of the first port member in the trunk.

Example

```
Console(config)#interface ethernet 1/1
Console(config-if)#ip igmp max-groups 10
Console(config-if)#
```

ip igmp max-groups action

This command sets the IGMP throttling action for an interface on the switch.

Syntax

ip igmp max-groups action {replace | deny}

- **replace** - The new multicast group replaces an existing group.
- **deny** - The new multicast group join report is dropped.

Default Setting

Deny

Command Mode

Interface Configuration

Command Usage

When the maximum number of groups is reached on a port, the switch can take one of two actions; either “deny” or “replace.” If the action is set to deny, any new IGMP join reports will be dropped. If the action is set to replace, the switch randomly removes an existing group and replaces it with the new multicast group.

Example

```
Console(config)#interface ethernet 1/1
Console(config-if)#ip igmp max-groups action replace
Console(config-if)#
```

show ip igmp filter

This command displays the global and interface settings for IGMP filtering.

Syntax

```
show ip igmp filter [interface interface]
```

interface

- **ethernet** *unit/port*
 - *unit* - Stack unit. (Range: 1)
 - *port* - Port number. (Range: 1-28/52)
- **port-channel** *channel-id* (Range: 1-8)

Default Setting

None

Command Mode

Privileged Exec

Example

```
Console#show ip igmp filter
IGMP filter enabled
Console#show ip igmp filter interface ethernet 1/1
Ethernet 1/1 information
-----
IGMP Profile 19
Deny
range 239.1.1.1 239.1.1.1
range 239.2.3.1 239.2.3.100
Console#
```

show ip igmp profile

This command displays IGMP filtering profiles created on the switch.

Syntax

```
show ip igmp profile [profile-number]
```

profile-number - An existing IGMP filter profile number.
(Range: 1-4294967295)

Default Setting

None

Command Mode

Privileged Exec

4 Command Line Interface

Example

```
Console#show ip igmp profile
IGMP Profile 19
IGMP Profile 50
Console#show ip igmp profile 19
IGMP Profile 19
  Deny
  range 239.1.1.1 239.1.1.1
  range 239.2.3.1 239.2.3.100
Console#
```

show ip igmp throttle interface

This command displays the interface settings for IGMP throttling.

Syntax

show ip igmp throttle interface [*interface*]

interface

- **ethernet** *unit/port*
 - *unit* - Stack unit. (Range: 1)
 - *port* - Port number. (Range: 1-28/52)
- **port-channel** *channel-id* (Range: 1-8)

Default Setting

None

Command Mode

Privileged Exec

Command Usage

Using this command without specifying an interface displays all interfaces.

Example

```
Console#show ip igmp throttle interface ethernet 1/1
Eth 1/1 Information
  Status : TRUE
  Action : Deny
  Max Multicast Groups : 32
  Current Multicast Groups : 0
Console#
```

Multicast VLAN Registration Commands

This section describes commands used to configure Multicast VLAN Registration (MVR). A single network-wide VLAN can be used to transmit multicast traffic (such as television channels) across a service provider's network. Any multicast traffic entering an MVR VLAN is sent to all subscribers. This can significantly reduce to processing overhead required to dynamically monitor and establish the distribution tree for a normal multicast VLAN. Also note that MVR maintains the user isolation and data security provided by VLAN segregation by passing only multicast traffic into other VLANs to which the subscribers belong.

Table 4-33 Multicast VLAN Registration Commands

Command	Function	Mode	Page
mvr	Globally enables MVR, statically configures MVR group address(es), or specifies the MVR VLAN identifier	GC	4-304
mvr	Configures an interface as an MVR receiver or source port, enables immediate leave capability, or configures an interface as a static member of the MVR VLAN	IC	4-305
show mvr	Shows information about the global MVR configuration settings, the interfaces attached to the MVR VLAN, or the multicast groups assigned to the MVR VLAN	PE	4-307

mvr (Global Configuration)

This command enables Multicast VLAN Registration (MVR) globally on the switch, statically configures MVR multicast group IP address(es) using the **group** keyword, or specifies the MVR VLAN identifier using the **vlan** keyword. Use the **no** form of this command without any keywords to globally disable MVR. Use the **no** form with the **group** keyword to remove a specific address or range of addresses. Or use the **no** form with the **vlan** keyword restore the default MVR VLAN.

Syntax

[no] mvr [group *ip-address* [*count*] | vlan *vlan-id*]

- *ip-address* - IP address for an MVR multicast group. (Range: 224.0.1.0 - 239.255.255.255)
- *count* - The number of contiguous MVR group addresses. (Range: 1-255)
- *vlan-id* - MVR VLAN ID (Range: 1-4094)

Default Setting

- MVR is disabled.
- No MVR group address is defined.
- The default number of contiguous addresses is 0.
- MVR VLAN ID is 1.

Command Mode

Global Configuration

Command Usage

- Use the **mvr group** command to statically configure all multicast group addresses that will join the MVR VLAN. Any multicast data associated an MVR group is sent from all source ports, and to all receiver ports that have registered to receive data from that multicast group.
- The IP address range from 224.0.0.0 to 239.255.255.255 is used for multicast streams. MVR group addresses cannot fall within the reserved IP multicast address range of 224.0.0.x.
- IGMP snooping must be enabled to allow a subscriber to dynamically join or leave an MVR group (see **ip igmp snooping** on page 4-288). Note that only IGMP version 2 or 3 hosts can issue multicast join or leave messages.

Example

The following example enables MVR globally, and configures a range of MVR group addresses:

```
Console(config)#mvr
Console(config)#mvr group 228.1.23.1 10
Console(config)#
```

mvr (Interface Configuration)

This command configures an interface as an MVR receiver or source port using the **type** keyword, enables immediate leave capability using the **immediate** keyword, or configures an interface as a static member of the MVR VLAN using the **group** keyword. Use the **no** form to restore the default settings.

Syntax

[no] mvr {type {receiver | source} | immediate | group ip-address}

- **receiver** - Configures the interface as a subscriber port that can receive multicast data.
- **source** - Configure the interface as an uplink port that can send and receive multicast data for the configured multicast groups.
- **immediate** - Configures the switch to immediately remove an interface from a multicast stream as soon as it receives a leave message for that group.
- **ip-address** - Statically configures an interface to receive multicast traffic from the IP address specified for an MVR multicast group.
(Range: 224.0.1.0 - 239.255.255.255)

Default Setting

- The port type is not defined.
- Immediate leave is disabled.
- No receiver port is a member of any configured multicast group.

Command Mode

Interface Configuration (Ethernet, Port Channel)

Command Usage

- A port which is not configured as an MVR receiver or source port can use IGMP snooping to join or leave multicast groups using the standard rules for multicast filtering.
- MVR receiver ports cannot be members of a trunk. Receiver ports can belong to different VLANs, but should not be configured as a member of the MVR VLAN. IGMP snooping can be used to allow a receiver port to dynamically join or leave multicast groups within the MVR VLAN. Multicast groups can also be statically assigned to a receiver port using the **group** keyword.
- One or more interfaces may be configured as MVR source ports. A source port is able to both receive and send data for multicast groups which it has joined through IGMP snooping or which have been statically assigned using the **group** keyword.
- The IP address range from 224.0.0.0 to 239.255.255.255 is used for multicast streams. MVR group addresses cannot fall within the reserved IP multicast address range of 224.0.0.x.
- Immediate leave applies only to receiver ports. When enabled, the receiver port is immediately removed from the multicast group identified in the leave message. When immediate leave is disabled, the switch follows the standard rules by sending a group-specific query to the receiver port and waiting for a response to determine if there are any remaining subscribers for that multicast group before removing the port from the group list.
- Using immediate leave can speed up leave latency, but should only be enabled on a port attached to one multicast subscriber to avoid disrupting services to other group members attached to the same interface.
- Immediate leave does not apply to multicast groups which have been statically assigned to a port.
- IGMP snooping must be enabled to allow a subscriber to dynamically join or leave an MVR group (see **ip igmp snooping** on page 4-288). Note that only IGMP version 2 or 3 hosts can issue multicast join or leave messages.

Example

The following configures one source port and several receiver ports on the switch, enables immediate leave on one of the receiver ports, and statically assigns a multicast group to another receiver port:

```
Console(config)#interface ethernet 1/5
Console(config-if)#mvr type source
Console(config-if)#exit
Console(config)#interface ethernet 1/6
Console(config-if)#mvr type receiver
Console(config-if)#mvr immediate
Console(config-if)#exit
Console(config)#interface ethernet 1/7
Console(config-if)#mvr type receiver
Console(config-if)#mvr group 225.0.0.5
Console(config-if)#
```

show mvr

This command shows information about the global MVR configuration settings when entered without any keywords, the interfaces attached to the MVR VLAN using the **interface** keyword, or the multicast groups assigned to the MVR VLAN using the **members** keyword.

Syntax

show mvr [**interface** *[interface]* | **members** *[ip-address]*]

- *interface*
 - **ethernet** *unit/port*
 - *unit* - Stack unit. (Range: 1)
 - *port* - Port number. (Range: 1-28/52)
 - **port-channel** *channel-id* (Range: 1-8)
- *ip-address* - IP address for an MVR multicast group. (Range: 224.0.1.0 - 239.255.255.255)

Default Setting

Displays global configuration settings for MVR when no keywords are used.

Command Mode

Privileged Exec

Command Usage

Enter this command without any keywords to display the global settings for MVR. Use the **interface** keyword to display information about interfaces attached to the MVR VLAN. Or use the **members** keyword to display information about multicast groups assigned to the MVR VLAN.

Example

The following shows the global MVR settings:

```
Console#show mvr
MVR Status:enable
MVR running status:TRUE
MVR multicast vlan:1
MVR Max Multicast Groups:255
MVR Current multicast groups:10
Console#
```

Table 4-34 show mvr - display description

Field	Description
MVR Status	Shows if MVR is globally enabled on the switch.
MVR running status	Indicates whether or not all necessary conditions in the MVR environment are satisfied.
MVR multicast vlan	Shows the VLAN used to transport all MVR multicast traffic.
MVR Max Multicast Groups	Shows the maximum number of multicast groups which can assigned to the MVR VLAN.
MVR Current multicast groups	Shows the number of multicast groups currently assigned to the MVR VLAN.

The following displays information about the interfaces attached to the MVR VLAN:

```

Console#show mvr interface
Port      Type           Status           Immediate Leave
-----
eth1/1    SOURCE         ACTIVE/UP        Disable
eth1/2    RECEIVER      ACTIVE/UP        Disable
eth1/5    RECEIVER      INACTIVE/DOWN    Disable
eth1/6    RECEIVER      INACTIVE/DOWN    Disable
eth1/7    RECEIVER      INACTIVE/DOWN    Disable
Console#

```

Table 4-35 show mvr interface - display description

Field	Description
Port	Shows interfaces attached to the MVR.
Type	Shows the MVR port type.
Status	Shows the MVR status and interface status. MVR status for source ports is "ACTIVE" if MVR is globally enabled on the switch. MVR status for receiver ports is "ACTIVE" only if there are subscribers receiving multicast traffic from one of the MVR groups, or a multicast group has been statically assigned to an interface.
Immediate Leave	Shows if immediate leave is enabled or disabled.

The following shows information about the interfaces associated with multicast groups assigned to the MVR VLAN:

```

Console#show mvr members
MVR Group IP      Status      Members
-----
225.0.0.1         ACTIVE     eth1/1 (d), eth1/2 (s)
225.0.0.2         INACTIVE   None
225.0.0.3         INACTIVE   None
225.0.0.4         INACTIVE   None
225.0.0.5         INACTIVE   None
225.0.0.6         INACTIVE   None
225.0.0.7         INACTIVE   None
225.0.0.8         INACTIVE   None
225.0.0.9         INACTIVE   None
225.0.0.10        INACTIVE   None
Console#

```

Table 4-36 show mvr members - display description

Field	Description
MVR Group IP	Multicast groups assigned to the MVR VLAN.
Status	Shows whether or not there are active subscribers for this multicast group. Note that this field will also display "INACTIVE" if MVR is globally disabled.
Members	Shows the interfaces with subscribers for multicast services provided through the MVR VLAN. Also shows if an interface has dynamically joined a multicast group (d), or if a multicast group has been statically bound to the interface (s).

IP Interface Commands

An IP addresses may be used for management access to the switch over your network. The IP address for this switch is obtained via DHCP by default. You can manually configure a specific IP address, or direct the device to obtain an address from a BOOTP or DHCP server when it is powered on. You may also need to establish a default gateway between this device and management stations or other devices that exist on another network segment.

Table 4-37 IP Interface Commands

Command	Function	Mode	Page
ip address	Sets the IP address for the current interface	IC	4-309
ip default-gateway	Defines the default gateway through which this switch can reach other subnetworks	GC	4-310
ip dhcp restart	Submits a BOOTP or DHCP client request	PE	4-311
show ip interface	Displays the IP settings for this device	PE	4-311
show ip redirects	Displays the default gateway configured for this device	PE	4-312
ping	Sends ICMP echo request packets to another node on the network	NE, PE	4-312

ip address

This command sets the IP address for the currently selected VLAN interface. Use the **no** form to restore the default IP address.

Syntax

ip address {*ip-address netmask* | **bootp** | **dhcp**}

no ip address

- *ip-address* - IP address
- *netmask* - Network mask for the associated IP subnet. This mask identifies the host address bits used for routing to specific subnets.
- **bootp** - Obtains IP address from BOOTP.
- **dhcp** - Obtains IP address from DHCP.

Default Setting

DHCP

Command Mode

Interface Configuration (VLAN)

Command Usage

- You must assign an IP address to this device to gain management access over the network. You can manually configure a specific IP address, or direct the device to obtain an address from a BOOTP or DHCP server. Valid IP addresses consist of four numbers, 0 to 255, separated by periods. Anything outside this format will not be accepted by the configuration program.

- If you select the **bootp** or **dhcp** option, IP is enabled but will not function until a BOOTP or DHCP reply has been received. Requests will be broadcast periodically by this device in an effort to learn its IP address. (BOOTP and DHCP values can include the IP address, default gateway, and subnet mask).
- You can start broadcasting BOOTP or DHCP requests by entering an **ip dhcp restart** command, or by rebooting the switch.

Note: Only one VLAN interface can be assigned an IP address (the default is VLAN 1). This defines the management VLAN, the only VLAN through which you can gain management access to the switch. If you assign an IP address to any other VLAN, the new IP address overrides the original IP address and this becomes the new management VLAN.

Example

In the following example, the device is assigned an address in VLAN 1.

```
Console(config)#interface vlan 1
Console(config-if)#ip address 192.168.1.5 255.255.255.0
Console(config-if)#
```

Related Commands

`ip dhcp restart (4-311)`

ip default-gateway

This command establishes a static route between this switch and devices that exist on another network segment. Use the **no** form to remove the static route.

Syntax

ip default-gateway *gateway*

no ip default-gateway

gateway - IP address of the default gateway

Default Setting

No static route is established.

Command Mode

Global Configuration

Command Usage

A gateway must be defined if the management station is located in a different IP segment.

Example

The following example defines a default gateway for this device:

```
Console(config)#ip default-gateway 10.1.1.254
Console(config)#
```

Related Commands

`show ip redirects (4-312)`

ip dhcp restart

This command submits a BOOTP or DHCP client request.

Default Setting

None

Command Mode

Privileged Exec

Command Usage

- This command issues a BOOTP or DHCP client request for any IP interface that has been set to BOOTP or DHCP mode via the **ip address** command.
- DHCP requires the server to reassign the client's last address if available.
- If the BOOTP or DHCP server has been moved to a different domain, the network portion of the address provided to the client will be based on this new domain.

Example

In the following example, the device is reassigned the same address.

```
Console(config)#interface vlan 1
Console(config-if)#ip address dhcp
Console(config-if)#end
Console#ip dhcp restart
Console#show ip interface
IP address and netmask: 192.168.1.54 255.255.255.0 on VLAN 1,
and address mode: DHCP.
Console#
```

Related Commands

ip address (4-309)

show ip interface

This command displays the settings of an IP interface.

Default Setting

All interfaces

Command Mode

Privileged Exec

Example

```
Console#show ip interface
IP address and netmask: 192.168.1.54 255.255.255.0 on VLAN 1,
and address mode:      User specified.
Console#
```

Related Commands

show ip redirects (4-312)

show ip redirects

This command shows the default gateway configured for this device.

Default Setting

None

Command Mode

Privileged Exec

Example

```
Console#show ip redirects
IP default gateway 10.1.0.254
Console#
```

Related Commands

ip default-gateway (4-310)

ping

This command sends ICMP echo request packets to another node on the network.

Syntax

ping *host* [**size** *size*] [**count** *count*]

- *host* - IP address or IP alias of the host.
- *size* - Number of bytes in a packet. (Range: 32-512, default: 32)
The actual packet size will be eight bytes larger than the size specified because the switch adds header information.
- *count* - Number of packets to send. (Range: 1-16, default: 5)

Default Setting

This command has no default for the host.

Command Mode

Normal Exec, Privileged Exec

Command Usage

- Use the ping command to see if another site on the network can be reached.
- Following are some results of the **ping** command:
 - *Normal response* - The normal response occurs in one to ten seconds, depending on network traffic.
 - *Destination does not respond* - If the host does not respond, a "timeout" appears in ten seconds.
 - *Destination unreachable* - The gateway for this destination indicates that the destination is unreachable.
 - *Network or host unreachable* - The gateway found no corresponding entry in the route table.
- Press <Esc> to stop pinging.

Example

```
Console#ping 10.1.0.9
Type ESC to abort.
PING to 10.1.0.9, by 5 32-byte payload ICMP packets, timeout is 5 seconds
response time: 10 ms
response time: 10 ms
response time: 10 ms
response time: 10 ms
response time: 10 ms
Ping statistics for 10.1.0.9:
 5 packets transmitted, 5 packets received (100%), 0 packets lost (0%)
Approximate round trip times:
  Minimum = 10 ms, Maximum = 20 ms, Average = 10 ms
Console#
```

Related Commands

interface (4-166)

IP Source Guard Commands

IP Source Guard is a security feature that filters IP traffic on network interfaces based on manually configured entries in the IP Source Guard table, or static and dynamic entries in the DHCP Snooping table when enabled (see “DHCP Snooping Commands” on page 4-317). IP source guard can be used to prevent traffic attacks caused when a host tries to use the IP address of a neighbor to access the network. This section describes commands used to configure IP Source Guard.

Table 4-38 IP Source Guard Commands

Command	Function	Mode	Page
ip source-guard	Configures the switch to filter inbound traffic based on source IP address, or source IP address and corresponding MAC address	IC	4-313
ip source-guard binding	Adds a static address to the source-guard binding table	GC	4-315
show ip source-guard	Shows whether source guard is enabled or disabled on each interface	PE	4-316
show ip source-guard binding	Shows the source guard binding table	PE	4-316

ip source-guard

This command configures the switch to filter inbound traffic based source IP address, or source IP address and corresponding MAC address. Use the **no** form to disable this function.

Syntax

```
ip source-guard {sip | sip-mac}
no ip source-guard
```

- **sip** - Filters traffic based on IP addresses stored in the binding table.

- **sip-mac** - Filters traffic based on IP addresses and corresponding MAC addresses stored in the binding table.

Default Setting

Disabled

Command Mode

Interface Configuration (Ethernet)

Command Usage

- Source guard is used to filter traffic on an unsecure port which receives messages from outside the network or firewall, and therefore may be subject to traffic attacks caused by a host trying to use the IP address of a neighbor.
- Setting source guard mode to "sip" or "sip-mac" enables this function on the selected port. Use the "sip" option to check the VLAN ID, source IP address, and port number against all entries in the binding table. Use the "sip-mac" option to check these same parameters, plus the source MAC address. Use the **no source guard** command to disable this function on the selected port.
- When enabled, traffic is filtered based upon dynamic entries learned via DHCP snooping, static entries configured in the DHCP snooping table, or static addresses configured in the source guard binding table.
- Table entries include a MAC address, IP address, lease time, entry type (Static-IP-SG-Binding, Dynamic-DHCP-Binding, Static-DHCP-Binding), VLAN identifier, and port identifier.
- Static addresses entered in the source guard binding table with the **ip source-guard binding** command (page 4-315) are automatically configured with an infinite lease time. Dynamic entries learned via DHCP snooping are configured by the DHCP server itself; static entries include a manually configured lease time.
- If the IP source guard is enabled, an inbound packet's IP address (sip option) or both its IP address and corresponding MAC address (sip-mac option) will be checked against the binding table. If no matching entry is found, the packet will be dropped.
- Filtering rules are implemented as follows:
 - If the DHCP snooping is disabled (see page 4-317), IP source guard will check the VLAN ID, source IP address, port number, and source MAC address (for the sip-mac option). If a matching entry is found in the binding table and the entry type is static IP source guard binding, the packet will be forwarded.
 - If the DHCP snooping is enabled, IP source guard will check the VLAN ID, source IP address, port number, and source MAC address (for the sip-mac option). If a matching entry is found in the binding table and the entry type is static IP source guard binding, static DHCP snooping binding or dynamic DHCP snooping binding, the packet will be forwarded.
 - If IP source guard is enabled on an interface for which IP source bindings (dynamically learned via DHCP snooping or manually configured) are not

4 Command Line Interface

yet configured, the switch will drop all IP traffic on that port, except for DHCP packets.

Example

This example enables IP source guard on port 5.

```
Console(config)#interface ethernet 1/5
Console(config-if)#ip source-guard sip
Console(config-if)#
```

Related Commands

- ip source-guard binding (4-315)
- ip dhcp snooping (4-317)
- ip dhcp snooping vlan (4-319)

ip source-guard binding

This command adds a static address to the source-guard binding table. Use the **no** form to remove a static entry.

Syntax

```
ip source-guard binding mac-address vlan vlan-id ip-address
interface ethernet unit/port
no ip source-guard binding mac-address vlan vlan-id
```

- *mac-address* - A valid unicast MAC address.
- *vlan-id* - ID of a configured VLAN (Range: 1-4094)
- *ip-address* - A valid unicast IP address, including classful types A, B or C.
- *unit* - Stack unit. (Range: 1)
- *port* - Port number. (Range: 1-28/52)

Default Setting

No configured entries

Command Mode

Global Configuration

Command Usage

- Table entries include a MAC address, IP address, lease time, entry type (Static-IP-SG-Binding, Dynamic-DHCP-Binding, Static-DHCP-Binding), VLAN identifier, and port identifier.
- All static entries are configured with an infinite lease time, which is indicated with a value of zero by the **show ip source-guard** command (page 4-316).
- When source guard is enabled, traffic is filtered based upon dynamic entries learned via DHCP snooping, static entries configured in the DHCP snooping table, or static addresses configured in the source guard binding table with this command.
- Static bindings are processed as follows:

- If there is no entry with same VLAN ID and MAC address, a new entry is added to binding table using the type of static IP source guard binding.
- If there is an entry with same VLAN ID and MAC address, and the type of entry is static IP source guard binding, then the new entry will replace the old one.
- If there is an entry with same VLAN ID and MAC address, and the type of the entry is dynamic DHCP snooping binding, then the new entry will replace the old one and the entry type will be changed to static IP source guard binding.

Example

This example configures a static source-guard binding on port 5.

```
Console(config)#ip source-guard binding 11-22-33-44-55-66 vlan 1
192.168.0.99 interface ethernet 1/5
Console(config-if)#
```

Related Commands

- ip source-guard (4-313)
- ip dhcp snooping (4-317)
- ip dhcp snooping vlan (4-319)

show ip source-guard

This command shows whether source guard is enabled or disabled on each interface.

Command Mode

Privileged Exec

Example

```
Console#show ip source-guard
Interface    Filter-type
-----
Eth 1/1     DISABLED
Eth 1/2     DISABLED
Eth 1/3     DISABLED
Eth 1/4     DISABLED
Eth 1/5     SIP
Eth 1/6     DISABLED
:
```

show ip source-guard binding

This command shows the source guard binding table.

Command Mode

Privileged Exec

Example

```

Console#show ip source-guard binding
-----
MacAddress      IpAddress      Lease(sec)  Type           VLAN  Interface
-----
11-22-33-44-55-66  192.168.0.99      0  Static           1     Eth 1/5
Console#
    
```

DHCP Snooping Commands

DHCP snooping allows a switch to protect a network from rogue DHCP servers or other devices which send port-related information to a DHCP server. This information can be useful in tracking an IP address back to a physical port. This section describes commands used to configure DHCP snooping.

Table 4-39 DHCP Snooping Commands

Command	Function	Mode	Page
ip dhcp snooping	Enables DHCP snooping globally	GC	4-317
ip dhcp snooping vlan	Enables DHCP snooping on the specified VLAN	GC	4-319
ip dhcp snooping trust	Configures the specified interface as trusted	IC	4-320
ip dhcp snooping verify mac-address	Verifies the client's hardware address stored in the DHCP packet against the source MAC address in the Ethernet header	GC	4-321
ip dhcp snooping information option	Enables or disables DHCP Option 82 information relay	GC	4-321
ip dhcp snooping information policy	Sets the information option policy for DHCP client packets that include Option 82 information	GC	4-322
ip dhcp snooping database flash	Writes all dynamically learned snooping entries to flash memory	GC	4-323
show ip dhcp snooping	Shows the DHCP snooping configuration settings	PE	4-323
show ip dhcp snooping binding	Shows the DHCP snooping binding table entries	PE	4-324

ip dhcp snooping

This command enables DHCP snooping globally. Use the **no** form to restore the default setting.

Syntax

[no] ip dhcp snooping

Default Setting

Disabled

Command Mode

Global Configuration

Command Usage

- Network traffic may be disrupted when malicious DHCP messages are received from an outside source. DHCP snooping is used to filter DHCP

messages received on an unsecured interface from outside the network or firewall. When DHCP snooping is enabled globally by this command, and enabled on a VLAN interface by the **ip dhcp snooping vlan** command (page 4-319), DHCP messages received on an untrusted interface (as specified by the **no ip dhcp snooping trust** command, page 4-320) from a device not listed in the DHCP snooping table will be dropped.

- When enabled, DHCP messages entering an untrusted interface are filtered based upon dynamic entries learned via DHCP snooping.
- Table entries are only learned for untrusted interfaces. Each entry includes a MAC address, IP address, lease time, entry type (Dynamic-DHCP-Binding, Static-DHCP-Binding), VLAN identifier, and port identifier.
- When DHCP snooping is enabled, the rate limit for the number of DHCP messages that can be processed by the switch is 100 packets per second. Any DHCP packets in excess of this limit are dropped.
- Filtering rules are implemented as follows:
 - If the global DHCP snooping is disabled, all DHCP packets are forwarded.
 - If DHCP snooping is enabled globally, and also enabled on the VLAN where the DHCP packet is received, all DHCP packets are forwarded for a *trusted* port. If the received packet is a DHCP ACK message, a dynamic DHCP snooping entry is also added to the binding table.
 - If DHCP snooping is enabled globally, and also enabled on the VLAN where the DHCP packet is received, but the port is *not trusted*, it is processed as follows:
 - * If the DHCP packet is a reply packet from a DHCP server (including OFFER, ACK or NAK messages), the packet is dropped.
 - * If the DHCP packet is from a client, such as a DECLINE or RELEASE message, the switch forwards the packet only if the corresponding entry is found in the binding table.
 - * If the DHCP packet is from client, such as a DISCOVER, REQUEST, INFORM, DECLINE or RELEASE message, the packet is forwarded if MAC address verification is disabled (as specified by the **ip dhcp snooping verify mac-address** command, page 4-321). However, if MAC address verification is enabled, then the packet will only be forwarded if the client's hardware address stored in the DHCP packet is the same as the source MAC address in the Ethernet header.
 - * If the DHCP packet is not a recognizable type, it is dropped.
 - If a DHCP packet from a client passes the filtering criteria above, it will only be forwarded to trusted ports in the same VLAN.
 - If a DHCP packet is from server is received on a trusted port, it will be forwarded to both trusted and untrusted ports in the same VLAN.
- If the DHCP snooping is globally disabled, all dynamic bindings are removed from the binding table.
- *Additional considerations when the switch itself is a DHCP client* – The port(s) through which the switch submits a client request to the DHCP server must be configured as trusted (**ip dhcp snooping trust**, page 4-320). Note that the

switch will not add a dynamic entry for itself to the binding table when it receives an ACK message from a DHCP server. Also, when the switch sends out DHCP client packets for itself, no filtering takes place. However, when the switch receives any messages from a DHCP server, any packets received from untrusted ports are dropped.

Example

This example enables DHCP snooping globally for the switch.

```
Console(config)#ip dhcp snooping
Console(config)#
```

Related Commands

`ip dhcp snooping vlan` (4-319)

`ip dhcp snooping trust` (4-320)

ip dhcp snooping vlan

This command enables DHCP snooping on the specified VLAN. Use the **no** form to restore the default setting.

Syntax

[no] ip dhcp snooping vlan *vlan-id*

vlan-id - ID of a configured VLAN (Range: 1-4094)

Default Setting

Disabled

Command Mode

Global Configuration

Command Usage

- When DHCP snooping enabled globally using the **ip dhcp snooping** command (page 4-317), and enabled on a VLAN with this command, DHCP packet filtering will be performed on any untrusted ports within the VLAN as specified by the **ip dhcp snooping trust** command (page 4-320).
- When the DHCP snooping is globally disabled, DHCP snooping can still be configured for specific VLANs, but the changes will not take effect until DHCP snooping is globally re-enabled.
- When DHCP snooping is globally enabled, configuration changes for specific VLANs have the following effects:
 - If DHCP snooping is disabled on a VLAN, all dynamic bindings learned for this VLAN are removed from the binding table.

Example

This example enables DHCP snooping for VLAN 1.

```
Console(config)#ip dhcp snooping vlan 1
Console(config)#
```

Related Commands

- ip dhcp snooping (4-317)
- ip dhcp snooping trust (4-320)

ip dhcp snooping trust

This command configures the specified interface as trusted. Use the **no** form to restore the default setting.

Syntax

[no] ip dhcp snooping trust

Default Setting

All interfaces are untrusted

Command Mode

Interface Configuration (Ethernet, Port Channel)

Command Usage

- An untrusted interface is an interface that is configured to receive messages from outside the network or firewall. A trusted interface is an interface that is configured to receive only messages from within the network.
- When DHCP snooping enabled globally using the **ip dhcp snooping** command (page 4-317), and enabled on a VLAN with this command, DHCP packet filtering will be performed on any untrusted ports within the VLAN according to the default status, or as specifically configured for an interface with the **no ip dhcp snooping trust** command.
- When an untrusted port is changed to a trusted port, all the dynamic DHCP snooping bindings associated with this port are removed.
- *Additional considerations when the switch itself is a DHCP client* – The port(s) through which it submits a client request to the DHCP server must be configured as trusted.

Example

This example sets port 5 to untrusted.

```
Console(config)#interface ethernet 1/5
Console(config-if)#no ip dhcp snooping trust
Console(config-if)#
```

Related Commands

- ip dhcp snooping (4-317)
- ip dhcp snooping vlan (4-319)

ip dhcp snooping verify mac-address

This command verifies the client's hardware address stored in the DHCP packet against the source MAC address in the Ethernet header. Use the **no** form to disable this function.

Syntax

```
[no] ip dhcp snooping verify mac-address
```

Default Setting

Enabled

Command Mode

Global Configuration

Command Usage

If MAC address verification is enabled, and the source MAC address in the Ethernet header of the packet is not same as the client's hardware address in the DHCP packet, the packet is dropped.

Example

This example enables MAC address verification.

```
Console(config)#ip dhcp snooping verify mac-address  
Console(config)#
```

Related Commands

- ip dhcp snooping (4-317)
- ip dhcp snooping vlan (4-319)
- ip dhcp snooping trust (4-320)

ip dhcp snooping information option

This command enables the DHCP Option 82 information relay for the switch. Use the **no** form to disable this function.

Syntax

```
[no] ip dhcp snooping information option
```

Default Setting

Disabled

Command Mode

Global Configuration

Command Usage

- DHCP provides a relay mechanism for sending information about the switch and its DHCP clients to the DHCP server. Known as DHCP Option 82, it allows compatible DHCP servers to use the information when assigning IP addresses, or to set other services or policies for clients.

- When the DHCP Snooping Information Option is enabled, clients can be identified by the switch port to which they are connected rather than just their MAC address. DHCP client-server exchange messages are then forwarded directly between the server and client without having to flood them to the entire VLAN.
- DHCP snooping must be enabled on the switch for the DHCP Option 82 information to be inserted into packets.

Example

This example enables the DHCP Snooping Information Option.

```
Console(config)#ip dhcp snooping information option
Console(config)#
```

ip dhcp snooping information policy

This command sets the DHCP snooping information option policy for DHCP client packets that include Option 82 information.

Syntax

ip dhcp snooping information policy <drop | keep | replace>

- **drop** - Discards the Option 82 information in a packet and then floods it to the entire VLAN.
- **keep** - Retains the client's DHCP information
- **replace** - Overwrites the DHCP client packet information with the switch's relay information.

Default Setting

replace

Command Mode

Global Configuration

Command Usage

When the switch receives DHCP packets from clients that already include DHCP Option 82 information, the switch can be configured to set the action policy for these packets. Either the switch can drop the DHCP packets, keep the existing information, or replace it with the switch's relay information.

Example

```
Console(config)#ip dhcp snooping information policy drop
Console(config)#
```

ip dhcp snooping database flash

This command writes all dynamically learned snooping entries to flash memory.

Command Mode

Global Configuration

Command Usage

This command can be used to store the currently learned dynamic DHCP snooping entries to flash memory. These entries will be restored to the snooping table when the switch is reset. However, note that the lease time shown for a dynamic entry that has been restored from flash memory will no longer be valid.

Example

```
Console(config)#ip dhcp snooping database flash
Console(config)#
```

show ip dhcp snooping

This command shows the DHCP snooping configuration settings.

Command Mode

Privileged Exec

Example

```
Console#show ip dhcp snooping
Global DHCP Snooping status: disable
DHCP Snooping is configured on the following VLANs:
1

Verify Source Mac-Address: enable

Interface          Trusted
-----
Eth 1/1            No
Eth 1/2            No
Eth 1/3            No
Eth 1/4            No
Eth 1/5            Yes
:
```

show ip dhcp snooping binding

This command shows the DHCP snooping binding table entries.

Command Mode

Privileged Exec

Example

```

Console#show ip dhcp snooping binding
-----
MacAddress      IpAddress      Lease(sec)  Type           VLAN  Interface
-----
11-22-33-44-55-66  192.168.0.99      0   Static        1     Eth 1/5
Console#

```

Switch Cluster Commands

Switch Clustering is a method of grouping switches together to enable centralized management through a single unit. A switch cluster has a “Commander” unit that is used to manage all other “Member” switches in the cluster. The management station uses Telnet to communicate directly with the Commander through its IP address, and the Commander manages Member switches using cluster “internal” IP addresses. There can be up to 36 Member switches in one cluster. Cluster switches are limited to within a single IP subnet.

Table 4-40 Switch Cluster Commands

Command	Function	Mode	Page
cluster	Configures clustering on the switch	GC	4-324
cluster commander	Configures the switch as a cluster Commander	GC	4-325
cluster ip-pool	Sets the cluster IP address pool for Members	GC	4-326
cluster member	Sets Candidate switches as cluster members	GC	4-326
rcommand	Provides configuration access to Member switches	GC	4-327
show cluster	Displays the switch clustering status	PE	4-327
show cluster members	Displays current cluster Members	PE	4-328
show cluster candidates	Displays current cluster Candidates in the network	PE	4-328

cluster

This command enables clustering on the switch. Use the **no** form to disable clustering.

Syntax

[no] cluster

Default Setting

Enabled

Command Mode

Global Configuration

Command Usage

- To create a switch cluster, first be sure that clustering is enabled on the switch (the default is enabled), then set the switch as a Cluster Commander. Set a Cluster IP Pool that does not conflict with any other IP subnets in the network. Cluster IP addresses are assigned to switches when they become Members and are used for communication between Member switches and the Commander.
- Switch clusters are limited to a single IP subnet (Layer 2 domain).
- A switch can only be a Member of one cluster.
- Configured switch clusters are maintained across power resets and network changes.

Example

```
Console(config)#cluster
Console(config)#
```

cluster commander

This command enables the switch as a cluster Commander. Use the **no** form to disable the switch as cluster Commander.

Syntax

[no] cluster commander

Default Setting

Disabled

Command Mode

Global Configuration

Command Usage

- Once a switch has been configured to be a cluster Commander, it automatically discovers other cluster-enabled switches in the network. These “Candidate” switches only become cluster Members when manually selected by the administrator through the management station.
- Cluster Member switches can be managed through using a Telnet connection to the Commander. From the Commander CLI prompt, use the **rcommand id** command to connect to the Member switch.

Example

```
Console(config)#cluster commander
Console(config)#
```

cluster ip-pool

This command sets the cluster IP address pool. Use the **no** form to reset to the default address.

Syntax

```
cluster ip-pool <ip-address>
```

```
no cluster ip-pool
```

ip-address - The base IP address for IP addresses assigned to cluster Members. The IP address must start 10.x.x.x.

Default Setting

10.254.254.1

Command Mode

Global Configuration

Command Usage

- An “internal” IP address pool is used to assign IP addresses to Member switches in the cluster. Internal cluster IP addresses are in the form 10.x.x.*member-ID*. Only the base IP address of the pool needs to be set since Member IDs can only be between 1 and 36.
- Set a Cluster IP Pool that does not conflict with addresses in the network IP subnet. Cluster IP addresses are assigned to switches when they become Members and are used for communication between Member switches and the Commander.
- You cannot change the cluster IP pool when the switch is currently in Commander mode. Commander mode must first be disabled.

Example

```
Console(config)#cluster ip-pool 10.2.3.4
Console(config)#
```

cluster member

This command configures a Candidate switch as a cluster Member. Use the **no** form to remove a Member switch from the cluster.

Syntax

```
cluster member mac-address <mac-address> id <member-id>
```

```
no cluster member id <member-id>
```

mac-address - The MAC address of the Candidate switch.

member-id - The ID number to assign to the Member switch.
(Range: 1-36)

Default Setting

No Members

Command Mode

Global Configuration

4 Command Line Interface

Command Usage

- The maximum number of cluster Members is 36.
- The maximum number of switch Candidates is 100.

Example

```
Console(config)#cluster member mac-address 00-12-34-56-78-9a id 5
Console(config)#
```

rcommand

This command provides access to a cluster Member CLI for configuration.

Syntax

rcommand id <member-id>

member-id - The ID number of the Member switch. (Range: 1-36)

Command Mode

Privileged Exec

Command Usage

- This command only operates through a Telnet connection to the Commander switch. Managing cluster Members using the local console CLI on the Commander is not supported.
- There is no need to enter the username and password for access to the Member switch CLI.

Example

```
Vty-0#rcommand id 1

      CLI session with the 24/48 L2/L4 GE Switch is opened.
      To end the CLI session, enter [Exit].

Vty-0#
```

show cluster

This command shows the switch clustering configuration.

Command Mode

Privileged Exec

Example

```
Console#show cluster
Role:                commander
Interval heartbeat:  30
Heartbeat loss count: 3
Number of Members:   1
Number of Candidates: 2
Console#
```

show cluster members

This command shows the current switch cluster members.

Command Mode

Privileged Exec

Example

```
Console#show cluster members
Cluster Members:
ID:          1
Role:        Active member
IP Address:  10.254.254.2
MAC Address: 00-12-cf-23-49-c0
Description: 24/48 L2/L4 IPV4/IPV6 GE Switch
Console#
```

show cluster candidates

This command shows the discovered Candidate switches in the network.

Command Mode

Privileged Exec

Example

```
Console#show cluster candidates
Cluster Candidates:
Role           Mac                Description
-----
ACTIVE MEMBER  00-12-cf-23-49-c0  24/48 L2/L4 IPV4/IPV6 GE Switch
CANDIDATE     00-12-cf-0b-47-a0  24/48 L2/L4 IPV4/IPV6 GE Switch
Console#
```

4 Command Line Interface

Appendix A: Software Specifications

Software Features

Authentication

Local, RADIUS, TACACS, Port (802.1X, MAC Authentication, Web Authentication), HTTPS, SSH, Port Security

Access Control Lists

IP, MAC; 100 rules per system

DHCP Client

Port Configuration

100BASE-TX: 10/100 Mbps, half/full duplex

1000BASE-T: 10/100 Mbps at half/full duplex, 1000 Mbps at full duplex

1000BASE-SX/LX/LH - 1000 Mbps at full duplex (SFP)

Flow Control

Full Duplex: IEEE 802.3-2005

Half Duplex: Back pressure

Broadcast Storm Control

Traffic throttled above a critical threshold

Port Mirroring

Multiple source ports, one destination port

Rate Limits

Input limit

Output limit

Port Trunking

Static trunks (Cisco EtherChannel compliant)

Dynamic trunks (Link Aggregation Control Protocol)

Spanning Tree Algorithm

Spanning Tree Protocol (STP, IEEE 802.1D)

Rapid Spanning Tree Protocol (RSTP, IEEE 802.1w)

Multiple Spanning Tree Protocol (MSTP, IEEE 802.1s)

VLAN Support

Up to 255 groups; port-based or tagged (802.1Q),

Private VLANs

Protocol-based VLANs

Class of Service

Supports 4 levels of priority and Weighted Round Robin Queueing (which can be configured by VLAN tag or port),

Layer 3/4 priority mapping: IP DSCP

Multicast Filtering

IGMP Snooping (Layer 2)

Multicast VLAN Registration

Quality of Service

DiffServ supports class maps, policy maps, and service policies

Additional Features

BOOTP client

SNTP (Simple Network Time Protocol)

SNMP (Simple Network Management Protocol)

RMON (Remote Monitoring, groups 1,2,3,9)

SMTP Email Alerts

DHCP Snooping

IP Source Guard

Switch Clustering

Management Features

In-Band Management

Telnet, Web-based HTTP or HTTPS, SNMP manager, or Secure Shell

Out-of-Band Management

RS-232 DB-9 console port

Software Loading

TFTP in-band or XModem out-of-band

SNMP

Management access via MIB database

Trap management to specified hosts

RMON

Groups 1, 2, 3, 9 (Statistics, History, Alarm, Event)

Standards

IEEE 802.1D Spanning Tree Protocol and traffic priorities

IEEE 802.1p Priority tags

IEEE 802.1Q VLAN

IEEE 802.1v Protocol-based VLANs

IEEE 802.1w Rapid Spanning Tree Protocol

IEEE 802.1X Port Authentication

IEEE 802.3-2005

Ethernet, Fast Ethernet, Gigabit Ethernet

Full-duplex flow control

Link Aggregation Control Protocol

IEEE 802.3ac VLAN tagging

DHCP Client (RFC 1541)

HTTPS

IGMP (RFC 1112)

IGMPv2 (RFC 2236)

RADIUS+ (RFC 2618)
RMON (RFC 1757 groups 1,2,3,9)
SNMP (RFC 1157)
SNMPv2 (RFC 2571)
SNMPv3 (RFC DRAFT 3414, 3410, 2273, 3411, 3415)
SNTP (RFC 2030)
SSH (Version 2.0)
TFTP (RFC 1350)

Management Information Bases

Bridge MIB (RFC 1493)
Differentiated Services MIB (RFC 3289)
Entity MIB (RFC 2737)
Ether-like MIB (RFC 2665)
Extended Bridge MIB (RFC 2674)
Extensible SNMP Agents MIB (RFC 2742)
Forwarding Table MIB (RFC 2096)
IGMP MIB (RFC 2933)
Interface Group MIB (RFC 2233)
Interfaces Evolution MIB (RFC 2863)
IP Multicasting related MIBs
MAU MIB (RFC 2668)
MIB II (RFC 1213)
Port Access Entity MIB (IEEE 802.1X)
Port Access Entity Equipment MIB
Private MIB
Quality of Service MIB
RADIUS Authentication Client MIB (RFC 2621)
RMON MIB (RFC 2819)
RMON II Probe Configuration Group (RFC 2021, partial implementation)
SNMPv2 IP MIB (RFC 2011)
SNMP Community MIB (RFC 3584)
SNMP Framework MIB (RFC 3411)
SNMP-MPD MIB (RFC 3412)
SNMP Target MIB, SNMP Notification MIB (RFC 3413)
SNMP User-Based SM MIB (RFC 3414)
SNMP View Based ACM MIB (RFC 3415)
TACACS+ Authentication Client MIB
TCP MIB (RFC 2013)
Trap (RFC 1215)
UDP MIB (RFC 2012)



Appendix B: Troubleshooting

Problems Accessing the Management Interface

Table B-1 Troubleshooting Chart

Symptom	Action
Cannot connect using Telnet, web browser, or SNMP software	<ul style="list-style-type: none">• Be sure the switch is powered up.• Check network cabling between the management station and the switch.• Check that you have a valid network connection to the switch and that the port you are using has not been disabled.• Be sure you have configured the VLAN interface through which the management station is connected with a valid IP address, subnet mask and default gateway.• Be sure the management station has an IP address in the same subnet as the switch's IP interface to which it is connected.• If you are trying to connect to the switch via the IP address for a tagged VLAN group, your management station, and the ports connecting intermediate switches in the network, must be configured with the appropriate tag.• If you cannot connect using Telnet, you may have exceeded the maximum number of concurrent Telnet/SSH sessions permitted. Try connecting again at a later time.
Cannot connect using Secure Shell	<ul style="list-style-type: none">• If you cannot connect using SSH, you may have exceeded the maximum number of concurrent Telnet/SSH sessions permitted. Try connecting again at a later time.• Be sure the control parameters for the SSH server are properly configured on the switch, and that the SSH client software is properly configured on the management station.• Be sure you have generated a public key on the switch, and exported this key to the SSH client.• Be sure you have set up an account on the switch for each SSH user, including user name, authentication level, and password.• Be sure you have imported the client's public key to the switch (if public key authentication is used).
Cannot access the on-board configuration program via a serial port connection	<ul style="list-style-type: none">• Be sure you have set the terminal emulator program to VT100 compatible, 8 data bits, 1 stop bit, no parity, and 9600 bps.• Check that the null-modem serial cable conforms to the pin-out connections provided in the Installation Guide.
Forgot or lost the password	<ul style="list-style-type: none">• Contact your local distributor.

Using System Logs

If a fault does occur, refer to the Installation Guide to ensure that the problem you encountered is actually caused by the switch. If the problem appears to be caused by the switch, follow these steps:

1. Enable logging.
2. Set the error messages reported to include all categories.
3. Designate the SNMP host that is to receive the error messages.
4. Repeat the sequence of commands or other actions that lead up to the error.
5. Make a list of the commands or circumstances that led to the fault. Also make a list of any error messages displayed.
6. Contact your distributor's service engineer.

For example:

```
Console(config)#logging on
Console(config)#logging history flash 7
Console(config)#snmp-server host 192.168.1.23
.
.
.
```

Glossary

Access Control List (ACL)

ACLs can limit network traffic and restrict access to certain users or devices by checking each packet for certain IP or MAC (i.e., Layer 2) information.

Boot Protocol (BOOTP)

BOOTP is used to provide bootup information for network devices, including IP address information, the address of the TFTP server that contains the devices system files, and the name of the boot file.

Class of Service (CoS)

CoS is supported by prioritizing packets based on the required level of service, and then placing them in the appropriate output queue. Data is transmitted from the queues using weighted round-robin service to enforce priority service and prevent blockage of lower-level queues. Priority may be set according to the port default, the packet's priority bit (in the VLAN tag), TCP/UDP port number, or DSCP priority bit.

Differentiated Services Code Point Service (DSCP)

DSCP uses a six-bit tag to provide for up to 64 different forwarding behaviors. Based on network policies, different kinds of traffic can be marked for different kinds of forwarding. The DSCP bits are mapped to the Class of Service categories, and then into the output queues.

Domain Name Service (DNS)

A system used for translating host names for network nodes into IP addresses.

Dynamic Host Control Protocol (DHCP)

Provides a framework for passing configuration information to hosts on a TCP/IP network. DHCP is based on the Bootstrap Protocol (BOOTP), adding the capability of automatic allocation of reusable network addresses and additional configuration options.

Extensible Authentication Protocol over LAN (EAPOL)

EAPOL is a client authentication protocol used by this switch to verify the network access rights for any device that is plugged into the switch. A user name and password is requested by the switch, and then passed to an authentication server (e.g., RADIUS) for verification. EAPOL is implemented as part of the IEEE 802.1X Port Authentication standard.

GARP VLAN Registration Protocol (GVRP)

Defines a way for switches to exchange VLAN information in order to register necessary VLAN members on ports along the Spanning Tree so that VLANs defined in each switch can work automatically over a Spanning Tree network.

Generic Attribute Registration Protocol (GARP)

GARP is a protocol that can be used by endstations and switches to register and propagate multicast group membership information in a switched environment so that multicast data frames are propagated only to those parts of a switched LAN containing registered endstations. Formerly called Group Address Registration Protocol.

Generic Multicast Registration Protocol (GMRP)

GMRP allows network devices to register end stations with multicast groups. GMRP requires that any participating network devices or end stations comply with the IEEE 802.1p standard.

Group Attribute Registration Protocol (GARP)

See Generic Attribute Registration Protocol.

IEEE 802.1D

Specifies a general method for the operation of MAC bridges, including the Spanning Tree Protocol.

IEEE 802.1Q

VLAN Tagging—Defines Ethernet frame tags which carry VLAN information. It allows switches to assign endstations to different virtual LANs, and defines a standard way for VLANs to communicate across switched networks.

IEEE 802.1p

An IEEE standard for providing quality of service (QoS) in Ethernet networks. The standard uses packet tags that define up to eight traffic classes and allows switches to transmit packets based on the tagged priority value.

IEEE 802.1X

Port Authentication controls access to the switch ports by requiring users to first enter a user ID and password for authentication.

IEEE 802.3ac

Defines frame extensions for VLAN tagging.

IEEE 802.3x

Defines Ethernet frame start/stop requests and timers used for flow control on full-duplex links. (Now incorporated in IEEE 802.3-2002)

IGMP Snooping

Listening to IGMP Query and IGMP Report packets transferred between IP Multicast Routers and IP Multicast host groups to identify IP Multicast group members.

IGMP Query

On each subnetwork, one IGMP-capable device will act as the querier — that is, the device that asks all hosts to report on the IP multicast groups they wish to join or to which they already belong. The elected querier will be the device with the lowest IP address in the subnetwork.

Internet Group Management Protocol (IGMP)

A protocol through which hosts can register with their local router for multicast services. If there is more than one multicast switch/router on a given subnetwork, one of the devices is made the “querier” and assumes responsibility for keeping track of group membership.

In-Band Management

Management of the network from a station attached directly to the network.

IP Multicast Filtering

A process whereby this switch can pass multicast traffic along to participating hosts.

Layer 2

Data Link layer in the ISO 7-Layer Data Communications Protocol. This is related directly to the hardware interface for network devices and passes on traffic based on MAC addresses.

Link Aggregation

See Port Trunk.

Link Aggregation Control Protocol (LACP)

Allows ports to automatically negotiate a trunked link with LACP-configured ports on another device.

Management Information Base (MIB)

An acronym for Management Information Base. It is a set of database objects that contains information about a specific device.

MD5 Message-Digest Algorithm

An algorithm that is used to create digital signatures. It is intended for use with 32 bit machines and is safer than the MD4 algorithm, which has been broken. MD5 is a one-way hash function, meaning that it takes a message and converts it into a fixed string of digits, also called a message digest.

Multicast Switching

A process whereby the switch filters incoming multicast frames for services for which no attached host has registered, or forwards them to all ports contained within the designated multicast VLAN group.

Network Time Protocol (NTP)

NTP provides the mechanisms to synchronize time across the network. The time servers operate in a hierarchical-master-slave configuration in order to synchronize local clocks within the subnet and to national time standards via wire or radio.

Out-of-Band Management

Management of the network from a station not attached to the network.

Port Authentication

See *IEEE 802.1X*.

Port Mirroring

A method whereby data on a target port is mirrored to a monitor port for troubleshooting with a logic analyzer or RMON probe. This allows data on the target port to be studied unobstructively.

Port Trunk

Defines a network link aggregation and trunking method which specifies how to create a single high-speed logical link that combines several lower-speed physical links.

Private VLANs

Private VLANs provide port-based security and isolation between ports within the assigned VLAN. Data traffic on downlink ports can only be forwarded to, and from, uplink ports.

Remote Authentication Dial-in User Service (RADIUS)

RADIUS is a logon authentication protocol that uses software running on a central server to control access to RADIUS-compliant devices on the network.

Remote Monitoring (RMON)

RMON provides comprehensive network monitoring capabilities. It eliminates the polling required in standard SNMP, and can set alarms on a variety of traffic conditions, including specific error types.

Rapid Spanning Tree Protocol (RSTP)

RSTP reduces the convergence time for network topology changes to about 10% of that required by the older IEEE 802.1D STP standard.

Secure Shell (SSH)

A secure replacement for remote access functions, including Telnet. SSH can authenticate users with a cryptographic key, and encrypt data connections between management clients and the switch.

Simple Network Management Protocol (SNMP)

The application protocol in the Internet suite of protocols which offers network management services.

Simple Network Time Protocol (SNTP)

SNTP allows a device to set its internal clock based on periodic updates from a Network Time Protocol (NTP) server. Updates can be requested from a specific NTP server, or can be received via broadcasts sent by NTP servers.

Spanning Tree Algorithm (STA)

A technology that checks your network for any loops. A loop can often occur in complicated or backup linked network systems. Spanning Tree detects and directs data along the shortest available path, maximizing the performance and efficiency of the network.

Telnet

Defines a remote communication facility for interfacing to a terminal device over TCP/IP.

Terminal Access Controller Access Control System Plus (TACACS+)

TACACS+ is a logon authentication protocol that uses software running on a central server to control access to TACACS-compliant devices on the network.

Transmission Control Protocol/Internet Protocol (TCP/IP)

Protocol suite that includes TCP as the primary transport protocol, and IP as the network layer protocol.

Trivial File Transfer Protocol (TFTP)

A TCP/IP protocol commonly used for software downloads.

User Datagram Protocol (UDP)

UDP provides a datagram mode for packet-switched communications. It uses IP as the underlying transport mechanism to provide access to IP-like services. UDP packets are delivered just like IP packets – connection-less datagrams that may be discarded before reaching their targets. UDP is useful when TCP would be too complex, too slow, or just unnecessary.

Virtual LAN (VLAN)

A Virtual LAN is a collection of network nodes that share the same collision domain regardless of their physical location or connection point in the network. A VLAN serves as a logical workgroup with no physical barriers, and allows users to share information and resources as though located on the same LAN.

XModem

A protocol used to transfer files between devices. Data is grouped in 128-byte blocks and error-corrected.

Index

Numerics

- 802.1Q tunnel 3-170, 4-251
 - configuration, guidelines 3-173
 - configuration, limitations 3-173
 - description 3-170
 - ethernet type 3-174
 - interface configuration 3-175, 4-252–4-253
 - mode selection 3-175
 - status, configuring 3-173
 - TPID 4-253
 - uplink 3-175
 - 802.1X, port authentication 3-82, 3-100
 - 802.1X, port authentication accounting 3-63
-

A

AAA

- accounting 802.1X port settings 3-63
- accounting exec command privileges 3-64
- accounting exec settings 3-66
- accounting summary 3-66
- accounting update 3-63
- accounting, configuring 3-61
- Authorization & Accounting 3-59
- authorization exec settings 3-69
- authorization settings 3-68
- authorization summary 3-69
- RADIUS group settings 3-60
- TACACS+ group settings 3-60
- acceptable frame type 3-168, 4-246
- Access Control List *See* ACL
- ACL
 - Extended IP 4-139, 4-140, 4-141
 - MAC 4-144, 4-145–4-147
 - Standard IP 4-139, 4-140, 4-141
- address table 3-134, 4-190, 4-193
- aging time 3-137, 4-193

authentication

- MAC 3-99
 - MAC address auth 3-94
 - MAC, configuring ports 3-99
 - network access 3-94
 - public key 3-74
 - web 3-89
 - web auth for ports, configuring 3-91
 - web auth port info, displaying 3-92
 - web auth, re-authenticating ports 3-93
 - web, configuring 3-90
-

B

- BOOTP 3-18, 4-215, 4-216, 4-309
 - BPDU 3-138
 - broadcast storm, threshold 3-126, 4-172
-

C

- Class of Service *See* CoS
 - CLI, showing commands 4-4
 - command line interface *See* CLI
 - community ports 3-177, 4-254
 - community string 2-6, 3-40, 3-45, 3-47, 3-48, 3-50, 4-152
 - community VLANs 3-178, 4-256
 - configuration settings, saving or restoring 2-8, 3-21, 4-85
 - console port, required connections 2-2
 - CoS
 - configuring 3-194, 4-264, 4-272
 - DSCP 3-201, 4-269
 - layer 3/4 priorities 3-199, 4-269
 - queue mapping 3-195, 4-267
 - queue mode 3-198, 4-265
 - traffic class weights 3-198, 4-266
-

D

- default gateway, configuration 3-16, 4-310
- default priority, ingress port 3-194, 4-265

default settings, system 1-6
 DHCP 3-18, 4-215, 4-216, 4-309
 client 3-16
 dynamic configuration 2-5
 DHCP snooping
 global configuration 4-317, 4-324,
 4-325
 specifying trusted interfaces 4-320
 verifying MAC addresses 4-321,
 4-322
 VLAN configuration 4-319
 Differentiated Code Point Service *See* DSCP
 Differentiated Services *See* DiffServ
 DiffServ 3-203, 4-272
 binding policy to interface 3-209,
 4-278
 class map 3-203, 4-273, 4-276
 policy map 3-206, 4-275
 service policy 3-209, 4-278
 downloading software 3-20, 4-85
 DSA encryption 3-76, 3-77
 DSCP
 enabling 3-200, 4-269
 mapping priorities 3-201, 4-270
 dynamic addresses, displaying 3-135,
 4-191
 dynamic VLAN assignment 3-94, 3-96,
 4-124

E

edge port, STA 3-148, 3-151, 4-229
 encryption
 DSA 3-76, 3-77
 RSA 3-76
 encryption RSA 3-77
 event logging 4-55
 exec command privileges,
 accounting 3-64
 exec settings, accounting 3-66
 exec settings, authorization 3-69

F

firmware
 displaying version 3-13, 4-83
 upgrading 3-20, 4-85

G

GARP VLAN Registration Protocol *See* GVRP
 gateway, default 3-16, 4-310
 GVRP
 enabling 3-161
 global setting 3-161, 4-239
 interface configuration 3-168, 4-240

H

hardware version, displaying 3-13,
 4-83
 HTTPS 3-70, 3-71, 4-43
 configuring 3-70
 replacing SSL cert 3-71
 HTTPS, secure server 3-70, 4-43

I

IEEE 802.1D 3-137, 4-219
 IEEE 802.1s 4-219
 IEEE 802.1w 3-137, 4-219
 IEEE 802.1X 3-82, 3-100, 4-112
 IGMP
 filter profiles, configuration 3-225
 filter, parameters 3-216
 filtering & throttling 3-223
 filtering & throttling, interface
 configuration 3-226
 filtering & throttling, status 3-224
 filtering/throttling 4-297
 filtering/throttling, configuring
 profile 4-299
 filtering/throttling, creating
 profile 4-298
 filtering/throttling, enabling 4-298
 filtering/throttling, interface
 settings 4-300-4-301
 groups, displaying 3-221, 4-291
 immediate leave, status 3-218
 Layer 2 3-215, 4-287
 query 3-215, 4-292
 query, Layer 2 3-217, 4-292
 snooping 3-215, 4-288
 snooping & query,

- parameters 3-216
- snoothing, configuring 3-216, 4-287
- importing user public keys 3-77
- ingress filtering 3-168, 4-246
- IP address
 - BOOTP/DHCP 3-18, 4-215, 4-216, 4-309, 4-311
 - setting 2-4, 3-16, 4-215, 4-216, 4-309
- IP precedence
 - enabling 3-200
- IP source guard
 - configuring static entries 4-315
 - setting filter criteria 4-313
- isolated ports 3-177, 4-254
- isolated VLAN, configuring 3-177

J

- jumbo frame 4-84

K

- key
 - private 3-72
 - public 3-72
 - user public, importing 3-77
- key pair
 - host 3-72
 - host, generating 3-76

L

- LACP
 - local parameters 4-186
 - partner parameters 4-186
 - protocol message statistics 4-186
- Link Layer Discovery Protocol - Media Endpoint Discovery See LLDP-MED
- Link Layer Discovery Protocol See LLDP
- link type, STA 3-149, 3-150, 3-152, 3-155, 3-158, 4-231, 4-232, 4-233
- LLDP 3-184
 - device statistics detail, displaying 3-193
 - device statistics, displaying 3-192
 - interface attributes,

- configuring 3-186
- local device information, displaying 3-189
- remote information, displaying 3-191
- remote port information, displaying 3-190
- timing attributes, configuring 3-184
- TLV 3-184, 3-187
- TLV, management address 3-187
- TLV, port description 3-187
- TLV, system capabilities 3-188
- TLV, system description 3-187
- TLV, system name 3-187
- LLDP-MED 3-184
 - notification, status 3-188
 - TLV 3-188
 - TLV, inventory 3-188
 - TLV, location 3-188
 - TLV, network policy 3-188
 - TLV, port capabilities 3-188
- logging
 - syslog traps 4-58
 - to syslog servers 4-57
- log-in, Web interface 3-2
- logon authentication 3-51, 4-91
 - RADIUS client 4-94
 - RADIUS server 4-94
 - TACACS+ client 3-54, 4-98
 - TACACS+ server 3-54, 4-98
- logon authentication, sequence 3-55, 4-92, 4-93
- logon authentication, settings 3-55

M

- MAC address authentication 3-94, 4-121
 - ports, configuring 3-95
 - reauthentication 3-95
- MAC authentication 3-99
 - ports, configuring 3-99
- main menu 3-4
- Management Information Bases (MIBs) A-3
- mirror port, configuring 3-128, 4-177

- MSTP 4-219
 - configuring 3-151
 - global settings 4-217
 - global settings, configuring 3-143
 - global settings, displaying 3-141
 - interface settings 4-218
 - interface settings, configuring 3-149, 3-156
 - interface settings, displaying 3-154
 - multicast filtering 3-215, 3-228, 3-243, 4-287
 - multicast groups 3-221, 4-291
 - displaying 4-291
 - static 3-221, 4-288, 4-289, 4-291
 - multicast services
 - configuring 3-222, 3-229, 3-230, 3-232, 4-288, 4-289
 - displaying 3-221, 4-291
 - multicast, filtering and throttling 4-298
 - multicast, static router port 3-220, 4-296
 - MVR
 - setting interface type 4-305
 - setting multicast groups 4-304
 - specifying a VLAN 4-304
 - using immediate leave 4-305
-
- N**
- network access
 - authentication 3-94, 4-121
 - dynamic VLAN assignment 4-124
 - port configuration 3-95
 - reauthentication 3-95, 4-127
 - secure MAC information 3-98, 4-129
-
- P**
- password, line 4-14, 4-15
 - passwords 2-4
 - administrator setting 3-52, 3-60, 3-61, 3-63, 3-66, 4-38
 - path cost 3-141, 3-148
 - method 3-145, 4-222
 - STA 3-141, 3-148, 4-222
 - port authentication 3-82, 3-100
 - port priority
 - configuring 3-194, 4-264, 4-272
 - default ingress 3-194, 4-265
 - STA 3-148, 4-228
 - port security, configuring 3-81, 4-111
 - port, statistics 3-130, 4-174
 - ports
 - autonegotiation 3-113, 4-168
 - broadcast storm threshold 3-126, 4-172
 - capabilities 3-113, 4-169
 - duplex mode 3-113, 4-167
 - flow control 3-113, 4-170
 - speed 3-113, 4-167
 - ports, configuring 3-111, 4-166
 - ports, mirroring 3-128, 4-177
 - primary VLAN 3-177
 - priority, default port ingress 3-194, 4-265
 - private key 3-72
 - private VLANs, configuring 3-177, 3-178, 4-255
 - private VLANs, displaying 3-177
 - problems, troubleshooting B-1
 - promiscuous ports 3-177, 4-254
 - protocol migration 3-151, 4-235
 - protocol VLANs 3-182
 - protocol VLANs, configuring 3-182
 - protocol VLANs, system configuration 3-183
 - public key 3-72
 - PVLAN
 - association 3-179
 - community ports 3-177, 4-254
 - configuring 3-177, 3-178
 - displaying 3-177
 - interface configuration 3-181
 - isolated ports 3-177, 4-254
 - isolated VLAN, configuring 3-177
 - primary VLAN 3-177
 - promiscuous ports 3-177, 4-254
-
- Q**
- QinQ Tunneling *See* 802.1Q
 - QoS 3-202, 4-272
 - Quality of Service *See* QoS
 - queue weights 3-198, 4-266

R

- RADIUS, logon authentication 4-94
- RADIUS, settings 3-55
- rate limits, setting 3-129, 4-179
- remote logging 4-58
- restarting the system 3-33, 4-24, 4-25
- RSA encryption 3-76, 3-77
- RSTP 3-137, 4-219
 - global configuration 4-219
 - global settings, configuring 3-143
 - global settings, displaying 3-141
 - interface settings, configuring 3-149
 - interface settings, displaying 3-147

S

- secure shell 3-72, 4-46
 - configuration 3-72, 4-49
- serial port
 - configuring 4-12
- show dot1q-tunnel 4-253
- Simple Network Management Protocol
 - See SNMP
- SNMP 3-38
 - community string 3-40, 3-45, 3-47, 3-48, 3-50, 4-152
 - enabling traps 3-41, 4-156
 - filtering IP addresses 3-108
 - trap manager 3-41, 4-154
- software
 - displaying version 3-13, 4-83
 - downloading 3-20, 4-85
- Spanning Tree Protocol See STA
- specifications, software A-1
- SSH 3-72
 - server, configuring 3-75
- SSH, configuring 3-72, 4-49
- SSL
 - replacing cert 3-71
- STA 3-137, 4-217
 - edge port 3-148, 3-151, 4-229
 - global settings, configuring 3-143, 4-218–4-223
 - global settings, displaying 3-141, 4-235
 - interface settings 4-227–4-235,

4-236

- interface settings, configuring 3-149
 - interface settings, displaying 3-147
 - link type 3-149, 3-150, 3-152, 3-155, 3-158, 4-231, 4-232, 4-233
 - path cost 3-141, 3-148, 4-227
 - path cost method 3-145, 4-222
 - port priority 3-148, 4-228
 - port/trunk loopback detection 3-139
 - protocol migration 3-151, 4-235
 - transmission limit 3-145, 4-223
- standards, IEEE A-2
 - startup files
 - creating 3-22
 - displaying 3-20, 4-78
 - setting 3-20, 4-90
 - static addresses, setting 3-134, 4-190
 - statistics
 - port 3-130, 4-174
 - STP 3-143, 4-219
 - STP *Also see* STA
 - summary, accounting 3-66
 - switchport dot1q-ethertype 4-253
 - switchport mode dot1q-tunnel 4-252
 - system clock, setting 3-34, 4-65
 - system logs 3-28
 - system mode, normal or QinQ 3-173, 4-251
 - system software, downloading from server 3-20

T

- TACACS+, logon authentication 3-54, 4-98
- TACACS+, settings 3-55
- time, setting 3-34, 4-65
- TPID 4-253
- traffic class weights 3-198, 4-266
- trap manager 2-7, 3-41, 4-154
- troubleshooting B-1
- trunk
 - configuration 3-115, 4-180
 - LACP 3-117, 4-182
 - static 3-116, 4-181
- Type Length Value See LLDP
- TLV

Type Length Value *See also*
LLDP-MED
TLV

U

upgrading software 3-20
UPnP 3-248
 configuration 3-248
user password 3-52, 3-60, 3-61, 3-63,
 3-66, 4-38, 4-39

V

VLANs 3-158–3-194, 4-238
 802.1Q tunnel mode 3-175
 adding static members 3-165,
 3-167, 4-248
 creating 3-164, 4-243
 description 3-158, 3-194
 displaying basic information 3-162,
 4-239
 displaying port members 3-162,
 4-250
 dynamic assignment 3-96, 4-124
 egress mode 3-169, 4-245
 interface configuration 3-168,

4-246–4-249

 private 3-176, 4-254
 protocol 3-182, 4-261
 protocol, configuring 3-182
 protocol, system configuration 3-183
voice VLAN 3-210, 4-280
VoIP Traffic 3-210, 4-280
 ports, configuring 3-211
 telephony OUI, configuring 3-213
 voice VLAN, configuring 3-210

W

web authentication 3-89
 configuring 3-90
 port information, displaying 3-92
 ports, configuring 3-91
 ports, re-authenticating 3-93
Web interface
 access requirements 3-1
 configuration buttons 3-3
 home page 3-2
 menu list 3-4
 panel display 3-3